

**Geneva's Park - Playground  
City of Pflugerville**

May 24, 2022

Shane Mize  
City of Pflugerville  
400 Immanuel Rd  
Pflugerville, TX 78691

Dear Shane Mize:

fun abounds is delighted to provide City of Pflugerville with this playground equipment proposal.

This design was developed with your specific needs in mind, and we look forward to discussing this project further with you to ensure your complete satisfaction. fun abounds is confident that this proposal will satisfy City of Pflugerville's functional, environmental, and safety requirements - and most importantly, bring joy and excitement to the children and families directly benefiting from your new playground.

You have our personal commitment to support this project and your organization in every manner possible. We look forward to continuing to develop a long-standing relationship with City of Pflugerville. We appreciate your consideration and value this opportunity to earn your business.

Sincerely,

Mike Giehl  
fun abounds  
114 Venice Street  
Sugar Land, TX 77478

Proposal # 125-154772-1

# Geneva's Park - Playground fun abounds

**Burke**

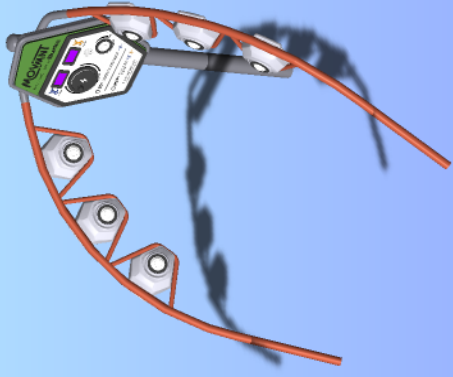
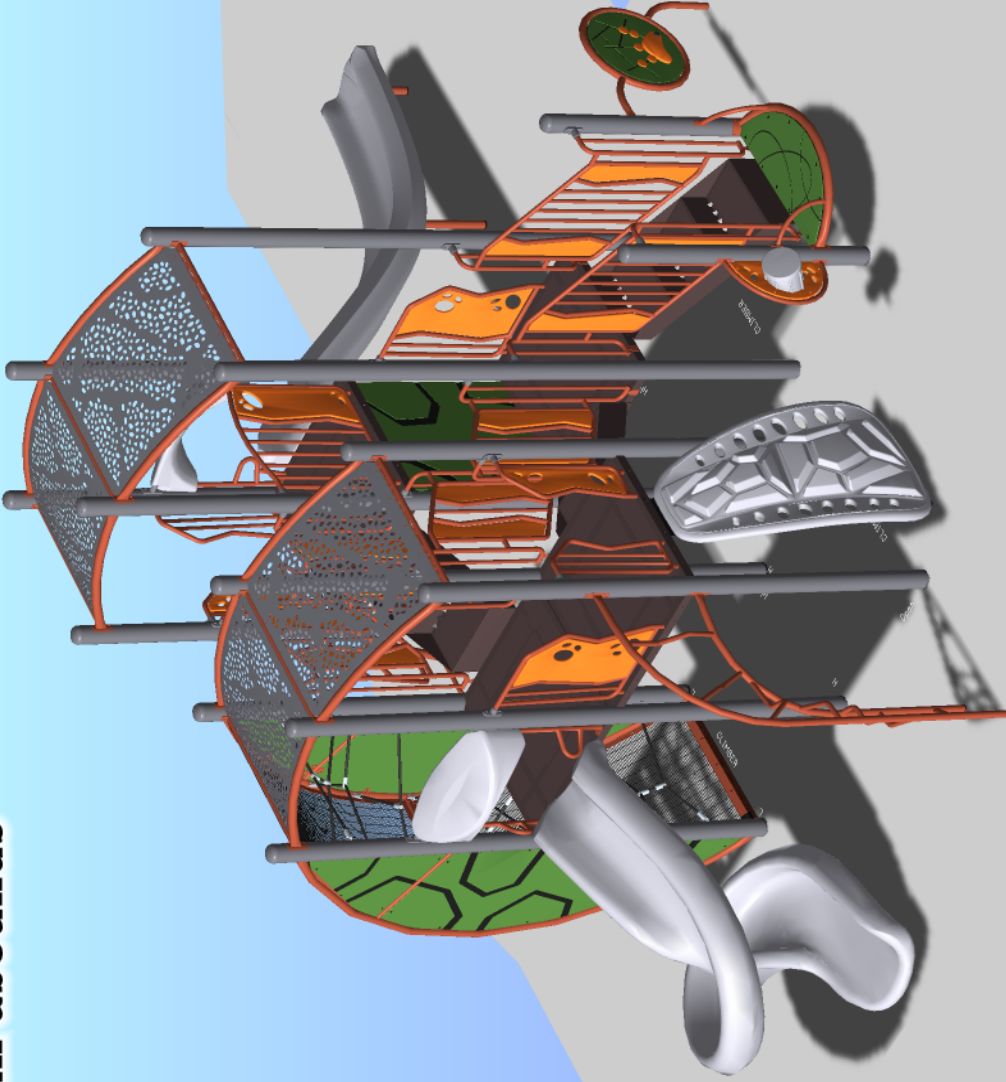

# PLAY THAT MOVES YOU<sup>®</sup>

At Burke, movement is our mantra. It drives our purpose and ignites our passion to bring the best in playground design and the most innovative, developmentally rich play, outdoor fitness and recreation products. Our research and testing push us to create new and unique ways to challenge children, families, schools, communities, teams and individuals to move, to grow and to play. Play fosters opportunities for connection between generations and with our peers, provides growth and togetherness and moves us in so many ways. Join Our Movement<sup>®</sup> and experience the many ways play can move you.

## PLAY FOR HEALTH

Movement is life and is one of the most important aspects in overall health and wellness for people of all ages and abilities. Burke has playground and fitness offerings that engage everyone in all stages of life to move. Our Nucleus<sup>®</sup> and Intensity<sup>®</sup> playgrounds feature a fusion of play that helps children engage in active play throughout the day for enhanced growth and developmental opportunities. ELEVATE<sup>®</sup> Fitness Course brings obstacle course fitness to a whole new level and is poised to engage children 5-12, teenagers and adults. ACTIVATE<sup>®</sup> Fitness Circuit and INVIGORATE<sup>®</sup> Dynamic Fitness are a great way to add events to a fitness trail or create a space for outdoor exercise. Our variety of fitness equipment will meet you where you are in your fitness journey and challenge you to be more.

## PLAY FOR YOUR MIND

Playful experiences are learning experiences and children at play are developing a wide-variety of skills that range from problem solving and cognitive planning to memory and self-regulation. Each and every time a child plays they are contributing positively to their cognitive development and setting themselves up for future success.

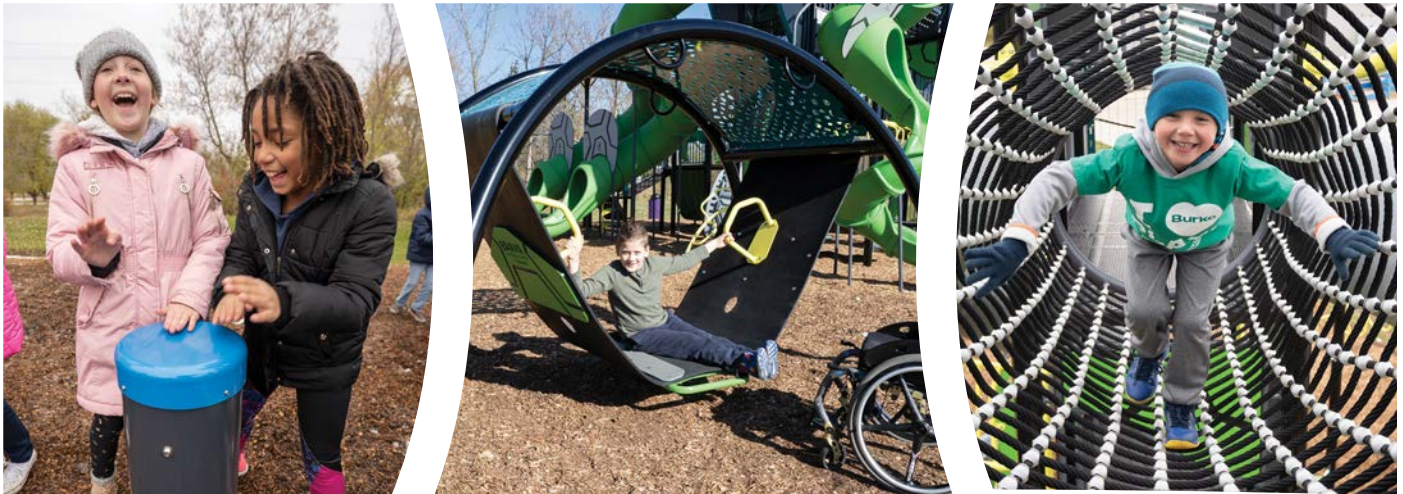

## PLAY FOR CONNECTION

Play provides us with common experiences, shared laughter and true connection. It brings communities together and helps us return to the simplicity of basic human connection and kindness. Parks and recreation spaces are critical because they lay the groundwork for the intergenerational engagement, interaction and development we all seek. Products such as Novo<sup>®</sup> Playful Furniture, with interesting pieces that can be used in a variety of ways, foster those opportunities by creating a space where everyone can interact and play together in their own way. The Konnection<sup>®</sup> Swing revolutionizes connection by promoting face-to-face connections and playing together. Every person of every age and ability brings their own unique experiences that enhance the collective and moves us all through play.

## PLAY FOR MOTION

Motion play creates a childhood experience like no other by creating movement for children of all abilities and providing developmental benefits, including increased spatial awareness, inner ear stimulation and balance. Motion can be a source of calm for children with sensory processing differences while providing delight and excitement for children of all ages.

## PLAY FOR DEVELOPMENT

Play is the work of childhood and helps children express themselves, monitor their emotions and develop a sense of identity that fuels their self-esteem and shapes their world view. Creating environments that foster this growth is at the heart of what we do at Burke and helps to teach resiliency and perseverance, all skills that transcend the playground and help children to develop into successful and healthy adults.

# WORK THAT MOVES US

Our mission is simple – to bring Play That Moves You® to communities around the world. This mission drives us each and every day to innovate the best in play, playgrounds, recreation and outdoor fitness equipment that help everyone find the best of themselves through play. We are passionate about our legacy of customer service and craftsmanship while looking to the future and always striving to be better.

At Burke, play inspires us to create a community of people that are invested in growth, aren't afraid to commit to positive change and seek to enrich and enhance the lives of the people in communities where we serve and live. Researching, innovating and creating products that help communities and people grow and thrive is the core of our purpose. In our own community, we partner with organizations such as the YMCA and Boys and Girls Club of Fond du Lac and we support, on a larger scale, organizations, municipalities, schools, churches and associations to Join Our Movement® and help let play lead the way for change. This is work that moves us and we hope the results move you.

## HANDCRAFTED IN AMERICA'S HEARTLAND

Walk through our Fond du Lac, WI manufacturing facility and you will see playgrounds coming to life through the hands of our people. In the age of assembly lines, we work to combine efficiency with a personal touch that makes every playground special. Bringing quality playgrounds to communities like yours is Work That Moves Us, and we hope the playgrounds we make move you too.

## SUPERIOR SERVICE

Customer Service is a hallmark of Burke and we take pride in the fact that when you call, we answer. We have factory-direct customer service representatives that are available to answer questions, help with replacement parts or field inquiries about installations.

## YOUR BURKE REPRESENTATIVE

We as Burke Representatives are passionate about bringing play to your community and helping you design your perfect play environment! We are knowledgeable and experienced about the entire playground process from site evaluation to design to maintenance and will work with you beyond installation to make sure your playground is, and remains, all you dreamed!

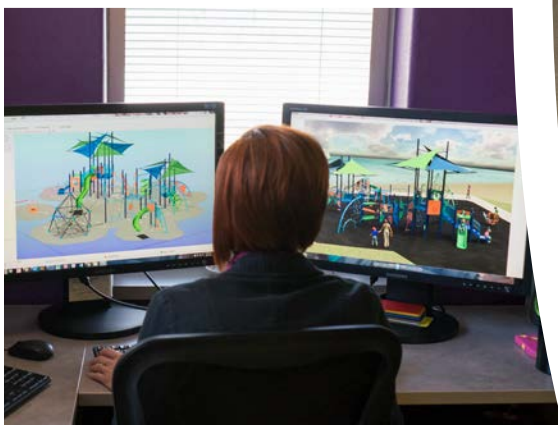

# BURKE'S HISTORY



## MORE THAN A CENTURY OF PLAY

Guided by our legacy of innovation, customer service and creativity, we are making the very best and most innovative playground, outdoor fitness and recreation products in our history! Our founder J.E. Burke set the course more than a century ago and we're taking his vision and making it even bigger! Through research, analysis and continuous improvement, we're designing products and playspaces that bring Play That Moves You® to communities for more fun, movement, engagement and development! Play is our passion, our mission and our business and we can't wait for you to Join Our Movement.



# BURKE BUILT QUALITY

## Discover the value of investing in a Burke Playground:

### **KOREKONNECT® DIRECT-BOLT CLAMP SYSTEM:**

Nucleus® features our Industry-leading KoreKonnnect direct-bolt clamp system resulting in the strongest and most accurate connection system ever. Factory located connection points make for easy, precise installation and an error-free fit. Best of all, KoreKonnnect is covered for 100 years under our non-prorated Generations Warranty®.

### **DIRECT-BOLT CONNECTION SYSTEM:**

Intensity®, ELEVATE® Fitness Course, ACTIVATE® Fitness Circuit and Synergy® feature Burke's trusted direct-bolt connection that uses a durable, straightforward direct-bolt system to ensure a trouble-free installation and provide the necessary strength to accommodate the demands of playing children. Like our KoreKonnnect system, Direct-Bolt connections are covered for 100 years under our Generations Warranty.

### **EZKONNECT® DECK MOUNTING SYSTEM:**

Our exclusive self-leveling deck attachment and factory CNC construction allows for faster and more precise location of decks during installation. The 2-bolt per corner deck attachment increases overall structure strength and stability.

### **PLATFORMS:**

Burke's oversized non-slip platforms are constructed of heavy-duty punched steel that can support more than 2 tons. Our vinyl coating is California compliant, free of lead and other hazardous heavy metals.

### **TAMPER-RESISTANT STAINLESS STEEL HARDWARE:**

All hardware is covered for 100 years under our Generations Warranty.

### **PREMIUM POWDER COATINGS:**

Our industry-leading powder coatings and finishes prevent fading, last longer and deter rust. We also offer a "coastal package" powder coat system. This special powder coat system for metal components and upright posts will provide additional corrosion and chemical protection along with added longevity to the color and gloss retention of the powder coated parts. Contact your Burke Representative for more information on colors, price and warranty.

### **COMPOUND PLASTICS WITH UV-20:**

You'll get long wear and bright, vibrant colors that hold up for years thanks to our thick, durable rotomolded plastics with UV-20 protection. This is why we can cover them for 15 years under our non-prorated Generations Warranty.

### **CLIMBING CABLES:**

Our climbing cables are flexible enough to provide movement, yet strong enough to last. Our ropes are made from 6 polyester cords with steel reinforcement wrapped around a synthetic fiber core. Each cord contains 8 galvanized steel strands tightly covered with polyester multi-fibers. Our RopeVenture® cables consist of 6 strands, each containing 24 stainless steel reinforcing strands within a nylon sleeve, wrapped around a solid nylon core.

### **ALUMINUM CONNECTORS:**

Swivel connectors at the end of our ropes allow assembly at any angle with no unwanted twists in the net. The aluminum fittings used to secure the joints are swaged in place to prevent any movement between the rope and fittings that could cause wear.



# FREE RESOURCES

## NPPS SAFETY KIT

Burke truly gives you the most value for your money. As part of our Total Cost of Ownership Package, we offer value-added resources FREE with every playground structure purchase. The National Program for Playground Safety (NPPS) Playground Supervision Safety Kit helps supervisors and educators be prepared on the playground. Learn more at [bciburke.com/safety](http://bciburke.com/safety).

## CUSTOM MAINTENANCE KIT

To help maintain a safe, functioning playground we include a custom maintenance schedule, touch-up paint, graffiti remover and carrying case FREE with every playground structure purchase.

## PLANNING & FUNDING TOOLS

We provide you with FREE tools to plan your playground from fundraising and design to installing a community build playground. At Burke, we understand the dedication and hard work it takes to raise the funds for playground equipment. That's why we created Funds for Fun, a direct donation fundraising program to help your organization raise the funds it needs for your new playground. We've also partnered with The School Funding Center to provide up-to-date grant information along with expert grant writing services. Learn more at [bciburke.com/funding](http://bciburke.com/funding).



**FREE WITH EVERY BURKE  
PLAY STRUCTURE PURCHASE**



**FREE FUNDRAISING TOOLS!**

# BIBA® PLAYGROUND GAMES

## ADD MORE PLAY, MOVEMENT AND FUN

Biba brings more engagement, more fun and more people to play. It's another way to view and expand Play That Moves You. Biba on a playground brings games to kids, families and communities that meet them where they are and challenges them to spend more time outdoors moving, playing and developing skills that transcend the playground. At its core, Biba features a variety of games including popular and recognizable characters that will engage and expand the play value of Burke playgrounds like never before. Biba brings imagination, movement and fun that can't be found anywhere else! All you need is the Biba App, a Burke playground featuring Biba and the readiness for a whole new kind of playground experience.

## PLAY TOGETHER

Engaging kids and families and creating an experience that fosters social, emotional, physical and cognitive development is part of what Biba on a Burke playground offers. When everyone is engaged, more time is spent at the playground getting that much-needed movement, building relationships and having fun outside.

## PLAY GAMES

Getting all the latest in playground games from the leader in outdoor mobile gaming is easy – just download the FREE App and find the nearest Biba playground and start having fun!

## PLAYGROUND ENHANCEMENT

Breathing new life into your existing playspace comes from finding fresh, innovative and fun ways to use the space. Enter Biba. Taking an existing playground and adding Biba expands the play value of your existing environment and enhances the playground experience so that every adventure is new again.

## STATS IN PLAY

Yes, stats in play...you read that right! With Biba on your playground, you can have statistics at your fingertips. These statistics help parents follow along with their children's progress, while helping park managers understand their park usage, comparing playground facility usage and helping provide quantitative data to support future budget requests. Stats and play unite with Biba!

**CALL YOUR LOCAL REPRESENTATIVE AT 800.266.1250 OR VISIT [BCIBURKE.COM/BIBA](http://BCIBURKE.COM/BIBA) TO LEARN MORE.**



Trademarks for Biba are the property of Biba Ventures Inc. © Copyright 2021 Biba Ventures Inc.



[BCIBURKE.COM](http://BCIBURKE.COM)

**Burke**

800.266.1250



# COOPERATIVE PURCHASING OPTIONS

## PLAYGROUNDS WITHOUT ALL THE PAPERWORK

Purchasing with contracts may sound intimidating, but getting your community playspace doesn't need to be a painful process of writing specifications, issuing RFP's and jumping through hoops – it can be simplified – we promise! As you continue planning for your new commercial playground, review the Purchasing Contracts offered through our partners. Purchasing with one of these contracts simplifies the process and ensures the design and intent remain the same – serving as a place for your community to gather, grow and thrive.

## EQUALIS GROUP

Equalis is an innovative cooperative purchasing organization that believes in the power of partnership and that when you work together you achieve more. The basic premise of the Equalis cooperative purchasing organization is to leverage the combined buying power of all members for better pricing and favorable contract terms. Equalis Group uses the lead agency model for competitively bid contracts, provides our participants the savings they expect and offers efficiencies and peace of mind within the procurement process. It is our mission to continuously improve the measurable and meaningful impact of cooperative services for everyone throughout the supply chain.

## OMNIA PARTNERS

OMNIA Partners, Public Sector (Subsidiary National IPA) is the largest and most experienced organization in purchasing and supply chain management. Comprised of participants and suppliers in the public sector, we bring together industry-leading buying power and world-class suppliers to offer an extensive portfolio of competitively solicited and publicly awarded contracts and partnerships. OMNIA Partners is proud to offer more value and resources to state and local government, higher education, K-12 education and non-profits.

## HGACBUY

Purchasing Burke playground equipment through HGACBuy gives your agency access to volume purchasing agreements and discounts, and there's no need to incur the time and expense of writing specs, issuing RFPs, advertising and evaluating bids. This can shorten your procurement cycle by months, while ensuring compliance with competitive bidding requirements.

## SOURCEWELL

As a leader in cooperative purchasing, Sourcewell is passionate about helping members fulfill their public service missions. Sourcewell builds strong relationships with members and vendors to develop practical solutions together.

The easiest way to Join Our Movement is to call your local Representative at 800.266.1250 or visit [bciburke.com/rep](http://bciburke.com/rep). Our passion is bringing play to communities like yours and we can't wait to help you get started!



# FEATURED PLAY EVENTS



## Extreme Twist Spiral Slide

The Extreme Twist is designed with a minimal footprint so there's more room for more play. Don't be fooled by the small footprint though, it's huge on fun and development. Sliding is an incredible way to enhance balance and coordination while developing turn taking and cooperation skills.

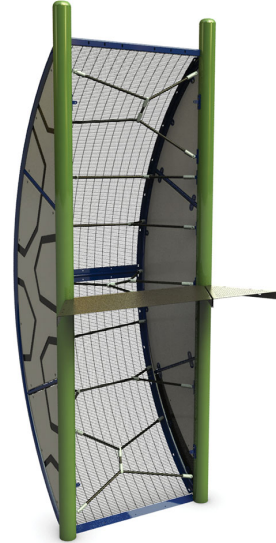

## Nucleus® Evolution® Arch Climber

Climbing up ropes to view the world from a different angle. Inspiring new panoramas, creating new vistas. You're protected but it looks open and new. A perspective like nothing you've ever experienced before.



## Pinball/Piston Ring Panel

Interactive and fun, our new Pinball/Piston Panel enhances cognitive development and fine motor skills while adding visual interest to your playspace, outdoor classroom or anywhere you need more play.

# FEATURED PLAY EVENTS



## CRESCENT DRUM PANEL

Create the perfect play area for children with Burke's Interactive Play Panels. The play panels encourage exploration, interaction and develop fine-motor skills for children with all abilities.



## EVOLUTION SQUARE ROOF

Burke's roofs offer protection from the damaging effects of the sun while still allowing children to have fun.

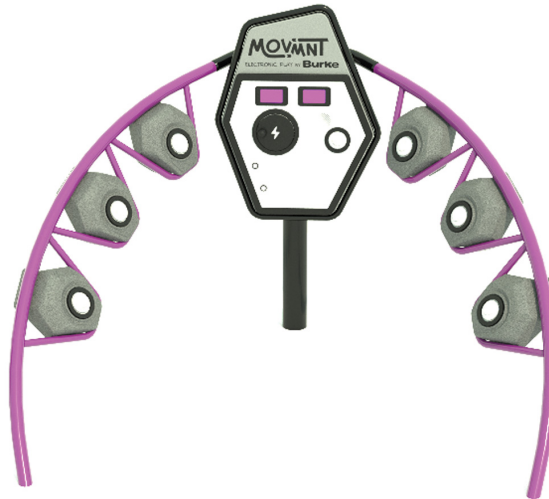

## MOV MNT Inclusive

MOV MNT is an electronic game that is powered by people. Users power up the game and dive into the numerous game options from single player to multi-player and individual achievement to team spirit. With two versions, everyone can play and be challenged at their level. Welcome to the MOV MNT.

# DESIGN SUMMARY

fun abounds is very pleased to present this proposal for consideration for the Geneva's Park - Playground located in Pflugerville. BCI Burke Company, LLC has been providing recreational playground equipment for over 90 years and has developed the right mix of world-class capabilities to meet the initial and continuing needs of City of Pflugerville. We believe our proposal will meet or exceed your project's requirements and will deliver the greatest value to you.

The following is a summary of some of the key elements of our proposal:

- Project Name: Geneva's Park - Playground
- Project Number: 125-154772-1
- User Capacity: 70
- Age Groups: Ages 5-12 years
- Dimensions: 29' 3" x 43' 7"
- Designer Name: Hunter Mielke

fun abounds has developed a custom playground configuration based on the requirements as they have been presented for the Geneva's Park - Playground playground project. Our custom design will provide a safe and affordable playground environment that is aesthetically pleasing, full of fun for all users and uniquely satisfies your specific requirements. In addition, proposal # 125-154772-1 has been designed with a focus on safety, and is fully compliant with ASTM F1487 and CPSC playground safety standards.

We invite you to review this proposal for the Geneva's Park - Playground playground project and to contact us with any questions that you may have.

Thank you in advance for giving us the opportunity to make this project a success.

INFORMATION  
MINIMUM FALL ZONE  
SURFACED WITH  
RESILIENT MATERIAL  
AREA

867 SQ.FT.

PERIMETER  
122 FT.

STRUCTURE SIZE  
29' 3" x 43' 7"

STRUCTURE IS DESIGNED  
FOR CHILDREN AGES:

- 6-23 MONTH OLDS
- 2-5 YEAR OLDS
- 5-12 YEAR OLDS
- 13 + YEAR OLDS



Registered to ISO 9001

Registered to ISO 14001



To verify product certification, visit [www.ipema.org](http://www.ipema.org)

The play components identified in this plan are IPEMA certified. The use and layout of these components conform to the requirements of ASTM F1487. To verify product certification, visit [www.ipema.org](http://www.ipema.org)

The space requirements shown here are to ASTM standards. Requirements for other standards may be different.

The use and layout of play components identified in this plan conform to the CPSC guidelines. U.S. CPSC recommends the separation of age groups in playground layouts.

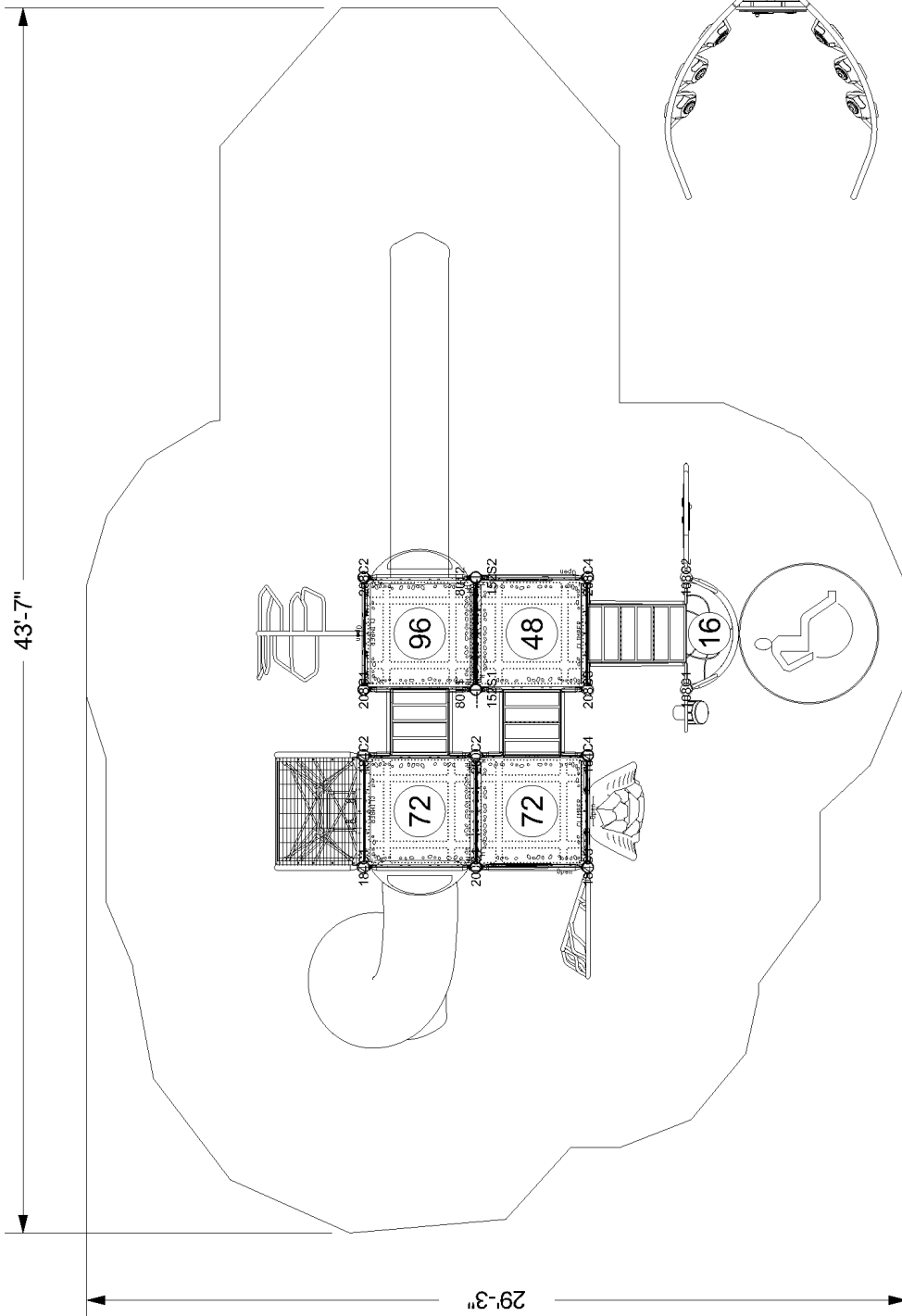

**WARNING!**

ACCESSIBLE SAFETY SURFACING MATERIAL IS REQUIRED BENEATH AND AROUND THIS EQUIPMENT.  
FOR SLIDE FALL ZONE SURFACING AREA SEE CPSC's Handbook for Public Playground Safety.  
PLATFORM HEIGHTS ARE IN INCHES ABOVE RESILIENT MATERIAL.

**ADA ACCESSIBILITY GUIDELINE (ADAAG CONFORMANCE)**

NUMBER OF PLAY EVENTS:	9
NUMBER OF ELEVATED PLAY EVENTS:	6
NUMBER OF ELEVATED PLAY EVENTS ACCESSIBLE BY RAMP:	PROVIDED: 0
NUMBER OF ELEVATED PLAY EVENTS ACCESSIBLE BY TRANSFER SYSTEM:	PROVIDED: 6
NUMBER OF ELEVATED PLAY EVENTS ACCESSIBLE BY RAMP OR TRANSFER SYSTEM:	PROVIDED: 3
NUMBER OF GROUND LEVEL PLAY EVENTS:	PROVIDED: 3
NUMBER OF TYPES OF GROUND LEVEL PLAY EVENTS:	PROVIDED: 3
NUMBER OF PLAY EVENTS:	9
NUMBER OF ELEVATED PLAY EVENTS:	6
NUMBER OF ELEVATED PLAY EVENTS ACCESSIBLE BY RAMP:	PROVIDED: 0
NUMBER OF ELEVATED PLAY EVENTS ACCESSIBLE BY TRANSFER SYSTEM:	PROVIDED: 6
NUMBER OF ELEVATED PLAY EVENTS ACCESSIBLE BY RAMP OR TRANSFER SYSTEM:	PROVIDED: 3
NUMBER OF GROUND LEVEL PLAY EVENTS:	PROVIDED: 3
NUMBER OF TYPES OF GROUND LEVEL PLAY EVENTS:	PROVIDED: 3



SERIES: Basics, Nucleus  
SITE PLAN  
DRAWN BY: Hunter Mielke

Geneva's Park - Playground  
1624 Royal Ascot Dr  
Pflugerville, TX 78660

May 24, 2022  
fun abounds  
125-154772-1

ITEM	COMP.	DESCRIPTION
1	270-0120	EVOLUTION UNITARY ENCLOSURE
2	270-0122	EVOLUTION OFFSET ENCLOSURE
3	270-0130	SQUARE PLATFORM
4	270-0297	48" ABSTRACT PLATFORM OFFSET
5	370-0039	EVOLUTION 24" TRANSITION ST.
6	370-0040	EVOLUTION 32" TRANSITION ST.
7	370-1642	VERVE CLIMBER 96" DK
8	370-1648	MANITOU CLIMBER 72"
9	370-1650	EVOLUTION, GROUND TO ROOF
10	370-1664	SHASTA CLIMBER, 40"-48"
11	370-1695	VIA CLIMBER 64"-72"
12	470-0075	CRESCENT PLATFORM
13	470-0758	VELO XL SLIDE, 88"-96" W/O HOC
14	470-0804	SLIDE HOOD, LOW SIDE WALL
15	470-0808	EVOLUTION ROOF, BOTTOM EDGE
16	470-0810	SQUARE ROOF, TOP EDGE, TWO
17	470-0867	EVOLUTION SQUARE ROOF
18	470-0872	EXTREME TWIST SPIRAL SLIDE
19	560-2625	MOVEMENT INCLUSIVE, FREESTAN
20	570-0100	EVOLUTION BARRIER
21	570-2704	DRUM CRESCENT PANEL
22	570-2729	CLASSIC GAME RING PANEL
23	670-0423	POST, FOOTER EXTENSION 5" O

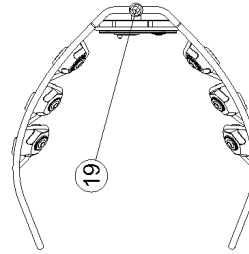
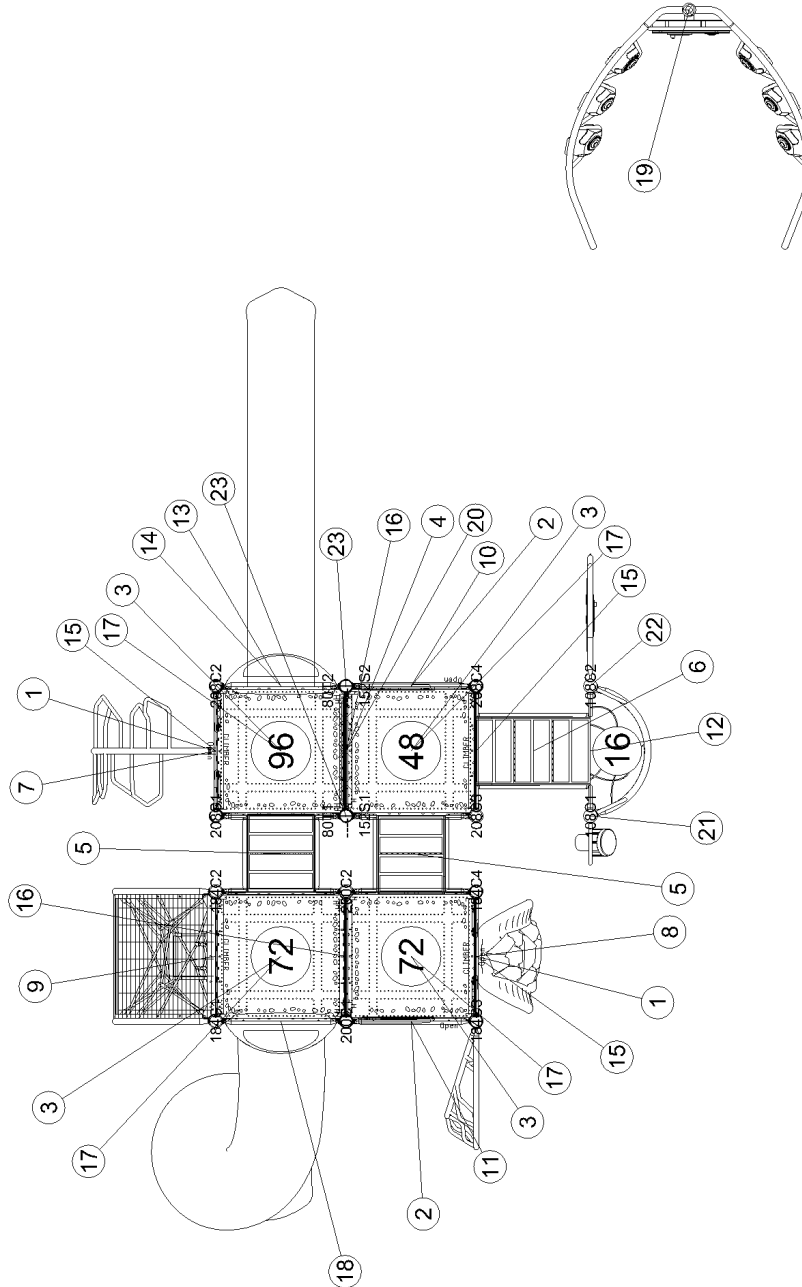

**Burke**

SERIES: Basics, Nucleus  
 COMPONENT PLAN  
 DRAWN BY: Hunter Mielke

Geneva's Park - Playground  
 1624 Royal Ascot Dr  
 Pflugerville, TX 78660

May 24, 2022

fun abounds  
 125-154772-1

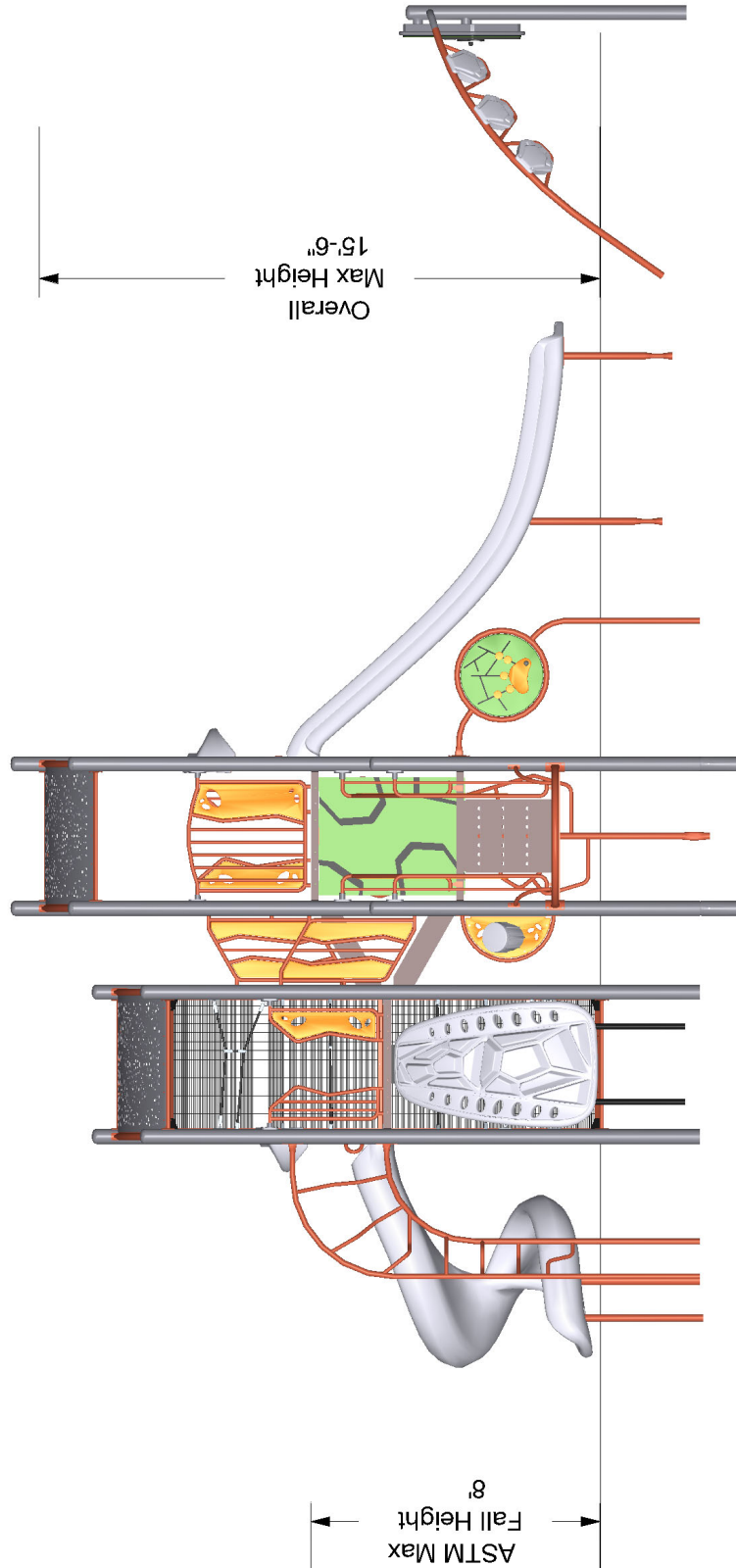

The protective surfacing for this design must accommodate the critical fall height.



May 24, 2022

SERIES: Basics, Nucleus  
 ELEVATION PLAN  
 DRAWN BY: Hunter Mielke

Geneva's Park - Playground  
 1624 Royal Ascot Dr  
 Pflugerville, TX 78660

fun abounds  
 125-154772-1

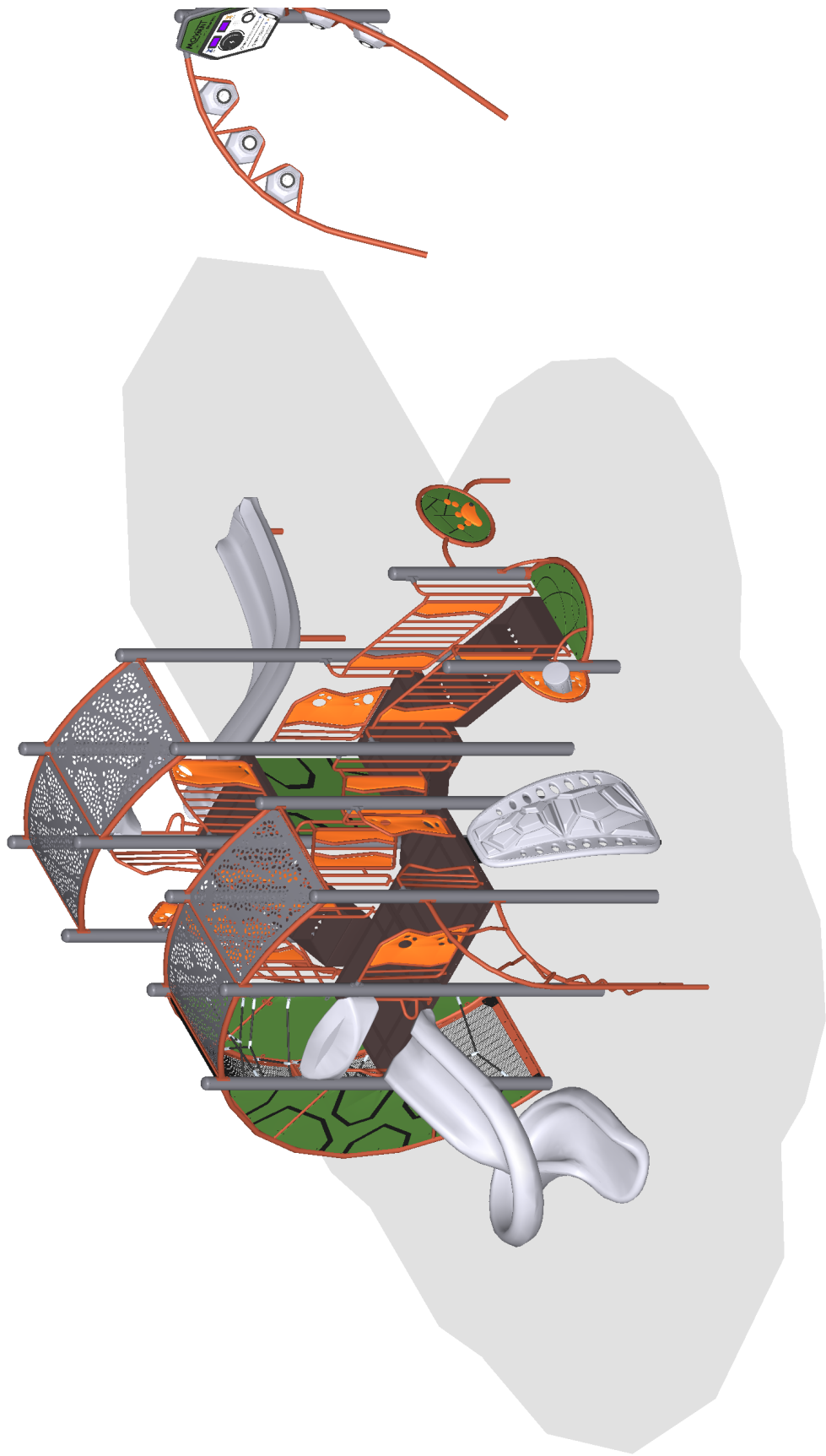

**Burke**

May 24, 2022

SERIES: Basics, Nucleus  
ISOMETRIC PLAN  
DRAWN BY: Hunter Mielke

Geneva's Park - Playground  
1624 Royal Ascot Dr  
Pflugerville, TX 78660

fun abounds  
125-154772-1





# Proposal # 125-154772-1

May 24, 2022  
2022 Pricing

**Proposal Prepared for:**

Shane Mize  
City of Pflugerville  
400 Immanuel Rd  
Pflugerville, TX 78691  
Phone: (512) 990-6357

**Project Location:**

Geneva's Park - Playground  
1624 Royal Ascot Dr  
Pflugerville, TX 78660

**Proposal Prepared by:**

fun abounds  
114 Venice Street  
Sugar Land, TX 77478  
Phone: 281-793-8002  
Fax: 281-265-0043

Mike Giehl  
Phone: 512-636-8260  
Fax: 281-265-0043  
mike@fabplaygrounds.com

Component No.	Description	Qty	User Cap	Ext. User Cap	Weight	Ext. Weight
Burke Basics						
560-2625	MOVMT INCLUSIVE, FREESTANDING	1	2	2	328	328
660-0101	INSTALL KIT, BURKE BASICS - P...	1	0	0	2	2
Nucleus						
072-0500-108C	5" OD X 108" CAPPED POST	2	0	0	57	114
072-0500-184C	5" OD X 184" CAPPED POST	4	0	0	96	384
072-0500-200C	5" OD X 200" CAPPED POST	2	0	0	105	210
072-0500-208C	5" OD X 208" CAPPED POST	4	0	0	109	436
072-0502-152S	5" OD X 152" SWAGED POST	2	0	0	80	160
072-5503-80T	5" OD X 80" TOP ALUMINUM CAPP...	2	0	0	16	32
270-0120	EVOLUTION UNITARY ENCLOSURE	2	0	0	34	68
270-0122	EVOLUTION OFFSET ENCLOSURE	2	0	0	34	68
270-0130	SQUARE PLATFORM	4	6	24	106	424
270-0297	48" ABSTRACT PLATFORM OFFSET ...	1	0	0	51	51
370-0039	EVOLUTION 24" TRANSITION STAI...	2	4	8	181	362
370-0040	EVOLUTION 32" TRANSITION STAI...	1	6	6	239	239
370-1642	VERVE CLIMBER 96" DK	1	6	6	67	67
370-1648	MANITOU CLIMBER 72"	1	4	4	86	86
370-1650	EVOLUTION, GROUND TO ROOF CLI...	1	7	7	471	471
370-1664	SHASTA CLIMBER, 40"-48"	1	2	2	20	20
370-1695	VIA CLIMBER 64"-72"	1	3	3	75	75
470-0075	CRESCENT PLATFORM	1	1	1	52	52
470-0758	VELO XL SLIDE, 88"-96" W/O HO...	1	2	2	134	134
470-0804	SLIDE HOOD, LOW SIDE WALL	1	0	0	32	32
470-0808	EVOLUTION ROOF BOTTOM EDGE	3	0	0	13	39
470-0810	SQUARE ROOF TOP EDGE, TWO SID...	2	0	0	14	28
470-0867	EVOLUTION SQUARE ROOF	4	0	0	76	304
470-0872	EXTREME TWIST SPIRAL SLIDE	1	2	2	217	217
570-0100	EVOLUTION BARRIER	1	0	0	52	52
570-2704	DRUM CRESCENT PANEL	1	1	1	16	16
570-2729	CLASSIC GAME RING PANEL	1	2	2	80	80
600-0104	NPPS SUPERVISION SAFETY KIT	1	0	0	3	3
660-0103	MAINTENANCE KIT, STRUCTURE	1	0	0	7	7
660-0104	INSTALLATION KIT, STRUCTURE	1	0	0	5	5
670-0423	POST, FOOTER EXTENSION 5" OD ...	2	0	0	11	22

Total User Capacity: 70



## Proposal # 125-154772-1

May 24, 2022  
2022 Pricing

Total Weight: 4,588 lbs.  
Total Price: \$79,355

Information is relative to the May 24 2022 4:35AM database.

**Special Notes:**

Prices do not include freight, unloading, material storage, site excavation/preparation, removal of existing equipment, removal of excess soil from footing holes, site security, safety surfacing, installation, or sales tax (if applicable). Prices are based on standard colors per CURRENT YEAR BCI Burke Catalog. Custom colors, where available, would be an extra charge. **Pricing is valid for 30 days from the date of this proposal.**



# Proposal # 125-154772-1

May 24, 2022  
2022 Pricing

## ***Selected Color List***

<b><u>Color Group</u></b>	<b><u>Color</u></b>
<i>Phase 1</i>	
Accessory	Redwood
1 Color Extruded/Flat	Orange
Kore Konnect	Charcoal
Platform	Brown
Post	Charcoal
Rotomolded	Granite
2 Color Extruded/Flat (outer)	Olive
2 Color Extruded/Flat (inner)	Black
Drums	Granite
<i>Phase 2</i>	
Accessory	Redwood
2 Color Extruded/Flat (outer)	Olive
2 Color Extruded/Flat (inner)	Black
Rotomolded	Granite
Post	Charcoal

# TESTIMONIALS

*"Service, Safety, Quality. Three words I would use to describe the people, business model, and overall organizational standards that inspires the BCI Burke Company. Every organization has a unique set of challenges and goals when it comes to building an educational environment - and from our experience, BCI Burke came to the table ready to work with us as partners to meet those challenges and goals head on.*

*We chose to work with BCI Burke because we needed a reliable company that would be able to provide nothing less than the highest quality product with our own time limitations. As with most other businesses, we did not have the luxury of making an investment into a project of this magnitude and not feel 100% certain that we had gotten the very best of our dollar. We also had to assure our stakeholders that we would see that investment last the test of time.*

*BCI Burke offered us superb and consistent customer service, the ability to achieve our goal on a fast timetable, and the confidence that our playground is genuinely the very best in design and safety. This is something that we will showcase in our school for many years to come.*

*After working with the company, I know personally they are committed to go the extra mile to satisfy your needs. BCI Burke is a master in their field but also provide the customer with an intuitive understanding of service".*

Angela H. Brunini  
Principal  
St. Anthony Catholic School

*"I am writing to tell you how much I enjoyed and appreciated working with your local representative...Through the years, I have worked with a number of playground companies, but never with anyone with the professionalism, commitment and follow-through of (your Burke Rep). We are all so excited about our children having the opportunity to play on your wonderful equipment; of course, we want everything! We are so impressed with the many, many possible designs. Thank you for the quality of your equipment and your local representatives."*

Nancy Emerson  
Director  
The Children's Center  
Dallas , TX

# COLORS THAT MOVE YOU

## POWDER COAT PAINT



## SOLIS HUE TOPPERS

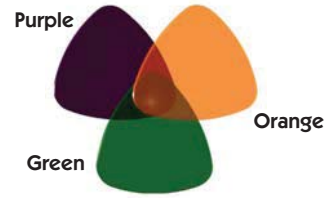

## ROCKIT CLIMBERS

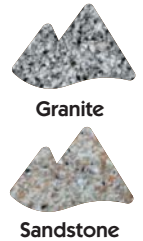

## PLATFORMS

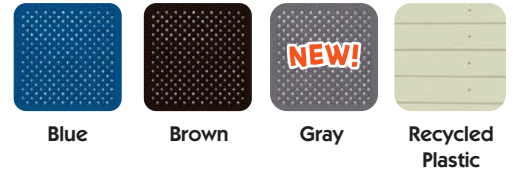

## HDPE PLASTIC PANELS



## SHADE CANOPIES

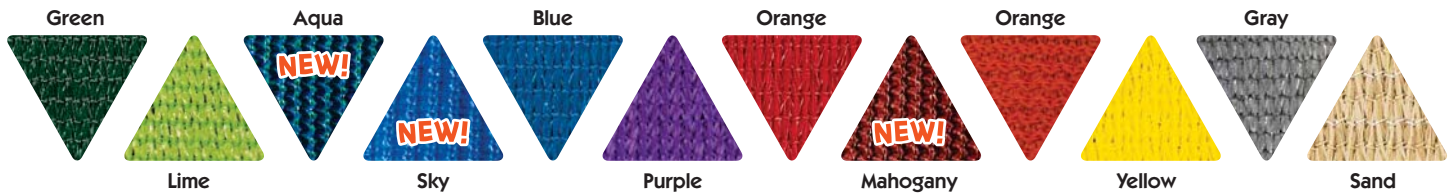

## ROTOMOLD PLASTIC

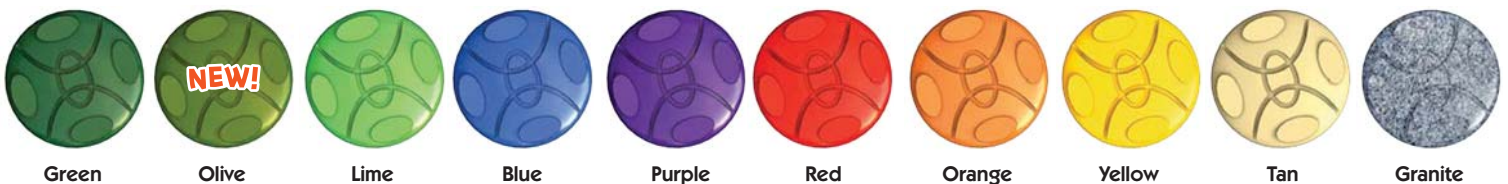

VISIT [BCIBURKE.COM/COLOR](http://BCIBURKE.COM/COLOR) TO CUSTOMIZE YOUR PLAYGROUND COLORS!

# BURKE GENERATIONS WARRANTY®

## The Longest and Strongest warranty in the industry

BCI Burke Company, LLC ("Burke") warrants that all standard products are warranted to be free from defects in materials and workmanship, under normal use and service, for a period of one (1) year from the date of shipment.

## We stand behind our products. In addition, the following products are warranted, under normal use and service from the date of shipment as follows:

- One Hundred (100) Year Limited Warranty on aluminum and steel upright posts (including Intensity®, Synergy™, Nucleus®, Voltage®, Little Buddies®, ELEVATE®, ACTIVATE®, INVIGORATE™) against structural failure due to corrosion, deterioration or workmanship.
- One Hundred (100) Year Limited Warranty on KoreConnect® clamps against structural failure due to corrosion, deterioration or workmanship.
- One Hundred (100) Year Limited Warranty on Hardware (nuts, bolts, washers)
- One Hundred (100) Year Limited Warranty on bolt-through fastening and clamp systems (Synergy™, Intensity®, Nucleus®, Voltage®, Little Buddies®, ELEVATE®).
- Twenty-Five (25) Year Limited Warranty on spring assemblies and aluminum cast animals.
- Fifteen (15) Year Limited Warranty on structure platforms and decks, metal roofs, table tops, bench tops, railings and barriers against structural failure due to materials or workmanship.
- Fifteen (15) Year Limited Warranty on all plastic components including StoneBorders against structural failure due to materials or workmanship.
- Ten (10) Year Limited Warranty on ShadePlay Canopies fabric, threads, and cables against degradation, cracking or material breakdown resulting from ultra-violet exposure, natural deterioration or manufacturing defects. This warranty is limited to the design loads as stated in the specifications.
- Ten (10) Year Limited Warranty on NaturePlay® Boulders and GFRC products against structural failure due to natural deterioration or workmanship. Natural wear, which may occur with any concrete product with age, is excluded from this warranty
- Ten (10) Year Limited Warranty on Full Color Custom Signage against manufacturing defects that cause delamination or degradation of the sign. Full Color Custom Signs also carry a two (2) year warranty against premature fading of the print and graphics on the signs.
- Five (5) Year Limited Warranty on Intensity® and RopeVenture® cables and LEVEL X® flex bridge against premature wear due to natural deterioration or manufacturing defects. Determination of premature wear will be at the manufacturer's discretion.
- Five (5) Year Limited Warranty on moving parts, including swing components, against structural failure due to materials or workmanship.
- Five (5) Year Limited Warranty on PlayEnsemble® cables and mallets against defects in materials and workmanship.
- Three (3) Year Limited Warranty on electronic panel speakers, sound chips and circuit boards against electronic failure caused by manufacturing defects.

The warranty stated above is valid only if the equipment is erected in conformity with the layout plan and/or installation instructions furnished by BCI Burke Company, LLC using approved parts; have been maintained and inspected in accordance with BCI Burke Company, LLC instructions. Burke's liability and your exclusive remedy hereunder will be limited to repair or replacement of those parts found in Burke's reasonable judgment to be defective. Any claim made within the above stated warranty periods must be made promptly after discovery of the defect. A part is covered only for the original warranty period of the applicable part. Replacement parts carry the applicable warranty from the date of shipment of the replacement from Burke. After the expiration of the warranty period, you must pay for all parts, transportation and service charges.

Burke reserves the right to accept or reject any claim in whole or in part. Burke will not accept the return of any product without its prior written approval. Burke will assume transportation charges for shipment of the returned product if it is returned in strict compliance with Burke's written instructions.

**THE FOREGOING WARRANTIES ARE EXCLUSIVE AND IN LIEU OF ANY OTHER WARRANTY, EXPRESS OR IMPLIED, INCLUDING BUT NOT LIMITED TO ANY IMPLIED WARRANTY OR MERCHANTABILITY OR FITNESS FOR A PARTICULAR PURPOSE. IF THE FOREGOING DISCLAIMER OF ADDITIONAL WARRANTIES IS NOT GIVEN FULL FORCE AND EFFECT, ANY RESULTING ADDITIONAL WARRANTY SHALL BE LIMITED IN DURATION TO THE EXPRESS WARRANTIES AND BE OTHERWISE SUBJECT TO AND LIMITED BY THE TERMS OF BURKE'S PRODUCT WARRANTY. SOME STATES DO NOT ALLOW THE EXCLUSION OF CERTAIN IMPLIED WARRANTIES, SO THE ABOVE LIMITATION MAY NOT APPLY TO YOU.**

**Warranty Exclusions:** The above stated warranties do not cover: "cosmetic" defects, such as scratches, dents, marring, or fading; damage due to incorrect installation, vandalism, misuse, accident, wear and tear from normal use, exposure to extreme weather, immersion in salt or chlorine water, unauthorized repair or modification, abnormal use, lack of maintenance, or other cause not within Burke's control; and

**Limitation of Remedies:** Burke is not liable for consequential or incidental damages, including but not limited to labor costs or lost profits resulting from the use of or inability to use the products or from the products being incorporated in or becoming a component of any other product. If, after a reasonable number of repeated efforts, Burke is unable to repair or replace a defective or nonconforming product, Burke shall have the option to accept return of the product, or part thereof, if such does not substantially impair its value, and return the purchase price as the buyer's entire and exclusive remedy. Without limiting the generality of the foregoing, Burke will not be responsible for labor costs involved in the removal of products or the installation of replacement products. Some states do not allow the exclusion of incidental damages, so the above exclusion may not apply to you.

The environment near a saltwater coast can be extremely corrosive. Some corrosion and/or deterioration is considered "normal wear" in this environment. Product installed within 500 yards of a saltwater shoreline will only be covered for half the period of the standard product warranty, up to a maximum of five years, for defects caused by corrosion. Products installed in direct contact with saltwater or that are subjected to salt spray are not covered by the standard warranty for any defects caused by corrosion.

Contact your local Burke Representative for warranty information regarding Burke Turf® and Burke Tile products.

### Terms of Sale

**Pricing:** Prices published in this catalog are in USD, are approximate and do not include shipping & handling, surfacing, installation nor applicable taxes. All prices are subject to change without notice. Contact your Burke representative for current pricing. Payments are to be made in USD.

**Weights:** Weights are approximate and may vary with actual orders.

**Installation:** All equipment is shipped unassembled. For a list of factory-certified installers in your area, please contact your Burke representative.

**Specifications:** Product specifications in this catalog were correct at the time of publication. However, product improvements are ongoing at Burke, and we reserve the right to change or discontinue specifications without notice.

**Loss or Damage in Transit:** A signed bill of lading is our receipt from a carrier that our shipment to you was complete and in good condition upon arrival. Before you sign, please check the Bill of Lading carefully when the shipment arrives to make sure nothing is missing and there are no damages. Once the shipment leaves our plant, we are no longer responsible for any damage, loss or shortage.

For more information regarding the warranty, call Customer Service at 920-921-9220 or 1-800-356-2070.

01/2022