



Contract Documents for Biological Nutrient Removal (BNR) Process Equipment – Phase 2

Solicitation #2019-5

City of Pflugerville Central Wastewater Treatment Plant Expansion

List of Documents

1. Notice of Award
2. 00 52 23 Agreement
3. 00 01 10 Table of Contents
4. 00 01 15 List of Drawings
5. Exhibit A 00 42 26 Price Proposal
6. Exhibit B
 - a. 00 45 23 Proposal Form
 - b. 00 45 01 Compliance to State Law on Nonresident Bidders
 - c. 00 45 02 Compliance to State Sales Tax Code
 - d. 00 45 03 Conflict of Interest Questionnaire
 - e. 00 45 04 Non-Collusion Affidavit
 - f. 00 45 17 Technical Requirements and Attachments 1 through 10 to 00 45 17
 - g. 00 61 13 Performance Bond
 - h. 00 61 16 Payment Bond
7. 00 72 00 General Conditions
8. 00 72 01 Insurance Requirements
9. 00 73 00 Supplementary Conditions
10. Bid Bond
11. Exhibit C – Technical Specifications
12. Exhibit D – Drawings

ACCEPTANCE OF NOTICE

Receipt of the above NOTICE OF AWARD is hereby acknowledged

Contractor: _____
(typed or printed name of organization)

Signature: _____
(individual's signature)

Name: _____
(typed or printed)

Title: _____
(typed or printed)

Date: _____
(typed or printed)

00 52 23 AGREEMENT FOR PHASE 2

This Agreement is between **the City of Pflugerville, Texas** (Buyer) and Ovivo USA, LLC (Seller). Buyer and Seller agree as follows:

ARTICLE 1 – GOODS AND SPECIAL SERVICES

- 1.01 Seller must provide all Goods and Special Services in accordance with the Procurement Contract Documents. The Goods and Special Services are generally described as follows:
Central Wastewater Treatment Plant Expansion Biological Nutrient Removal (BNR) Process Equipment Phase 2.

ARTICLE 2 – THE PROJECT

- 2.01 The Project for which the Goods and Special Services under the Procurement Contract Documents may be the whole or only a part is generally described as Central Wastewater Treatment Plant Expansion, Phase 2. The anticipated date that the Phase 2 Contractor will be assigned this Agreement is on or about September 2021.

ARTICLE 3 – DESIGN PROFESSIONAL AND PROJECT CONSTRUCTION MANAGER

- 3.01 The Design Professional (“Engineer”) for this Procurement Contract is:
Freese and Nichols, Inc.
10431 Morado Circle, Suite 300
Austin, TX 78759
- 3.02 The Project Construction Manager (“Contractor” or “PCM”) for this Procurement Contract is:
[Name of Contractor]
[Office Address]
[City, State, Zip Code]

ARTICLE 4 – POINT OF DESTINATION

- 4.01 The Goods are to be delivered to the Point of Destination identified in the Procurement Contract Documents.

ARTICLE 5 – SPECIAL TERMS AND CONDITIONS FOR EQUIPMENT PURCHASE

- 5.01 The Project will require the purchase of specialized equipment, based on the final engineering design for the Wastewater Treatment Plant Expansion. Due to the highly specialized nature of the required equipment, the Buyer and Seller hereby agree to the following special terms and conditions:
 - A. Due to the requirement that Phase 1 has to be completed before Phase 2 can be implemented, a price for Phase 2 equipment will need to be subject to the “Escalation Methodology”, described more thoroughly in Exhibit A Escalation Methodology and Formula for Phase 2 Price.

- B. Assignment of Agreement to Phase 2 Contractor: Concurrently with the execution of the Phase 2 construction agreement between Buyer and Phase 2 Contractor all rights, interests and responsibilities (“contractual obligations”) belonging to the Buyer shall be assigned to the Phase 2 Contractor.
- C. Equipment Purchase Order Date: The Phase 2 Contractor Equipment Purchase Order Date is October 26, 2021. The Phase 2 construction contractor shall place the Equipment Purchase Order on or before the Equipment Purchase Order Date. Should the Phase 2 construction contractor fail to purchase the required equipment within the allotted timeframe, then the Phase 2 construction contractor shall be responsible for any additional costs and expenses incurred.
- D. Termination for Convenience: The Buyer has the right to, in its sole discretion, to terminate for convenience the Phase 2 equipment purchase at any time prior to the assignment of the Agreement to the Phase 2 Contractor by providing written notice. If Buyer exercises its right to terminate for convenience such termination will be without any penalty or cost whatsoever.
- E. Key Personnel. The personnel named below will be defined as Key Personnel and will be dedicated to the project and shall only be substituted with the Buyer’s prior approval.
 - 1. Key Personnel:
 - a. Lisa Powers, Project Manager
 - b. Barry Mercer, Representative for Installation Checks and Start-up
 - c. Tom Leland- Representative for Training
- F. Key Personnel shall not be replaced without the prior written approval of the Buyer. Any Key Personnel replacement proposed by the Seller shall be an individual as qualified and experienced or better qualified and experienced than the Key Personnel individual replaced. Seller shall provide evidence to demonstrate qualifications and experience. Bonds: At the time of this Agreement’s assignment, Seller shall provide a bid bond for 5% of contract value to Phase 2 Contractor to be held as security until the Phase 2 Equipment Purchase Agreement is executed at which time 100% payment and performance bonds will be provided by Seller to Phase 2 Contractor.

ARTICLE 6 – PROCUREMENT CONTRACT TIMES

6.01 Procurement Contract Times

- A. Shop Drawings required by the Procurement Contract Documents will be submitted to Buyer for Design Professional’s review and approval within 30 days after the date when the Procurement Contract Times commence to run as provided in the General Conditions.
- B. Date for delivery of templates, baseplates, anchor bolts or other materials required for construction prior to the delivery of other Goods per Paragraph 6.01.C must be determined within 30 days after approval of Shop Drawings.
- C. The Goods are required to be delivered complete and ready for assembly and installation within **[specify duration; to be decided during negotiations with Contractor]** calendar days after the date when the Procurement Contract Times commence to run as provided in the General Conditions.

- D. Date for Furnishing Special Services: The furnishing of Special Services to Buyer will commence within 30 days after Buyer's written notice to Seller following Buyer's receipt of delivery of the Goods and must be completed within 14 days thereafter. This may require multiple visits depending on the Seller's delivery schedule.

6.02 Time is of the Essence

- A. All time limits for Milestones, if any, the delivery of Goods and the furnishing of Special Services as stated in the Procurement Contract Documents are of the essence of the Procurement Contract.

6.03 Liquidated Damages

- A. Buyer and Seller recognize that times specified for Milestones and deliveries of Goods for installation as stated in the Procurement Contract Documents are of the essence of the Procurement Contract. Buyer and Seller recognize that the Buyer will suffer financial loss if the Goods are not delivered ready for installation within the times specified in Paragraph 6.01 and as adjusted in accordance with the General Conditions. Buyer and Seller also recognize the delays, expense, and difficulties involved in proving the actual loss suffered by Buyer if complete acceptable Goods are not delivered on time. Accordingly, instead of requiring any such proof, Buyer and Seller agree that as liquidated damages for delay (but not as a penalty):
 1. Except in cases of Force Majeure, Seller will pay Buyer One Thousand Dollars (\$1,000) for each working day that elapses after the time specified in Paragraph 6.01 for delivery of Goods suitable for installation until the Goods are delivered and ready to install. Maximum liquidated damages, in the aggregate, will not exceed ten percent (10%) the value of the Procurement Contract. Seller shall not be liable to pay liquidated damages for Buyer caused delays in accordance with the Agreement. Notwithstanding any other provision of the Agreement to the contrary, payment of liquidated damages shall be Seller's sole liability and Buyer's sole remedy for late delivery of equipment. Such remedies shall not be enforced unless Buyer suffers an economic loss as a result of Seller's late delivery, however, Buyer's oral or written statement of loss shall be sufficient evidence to support a Liquidated Damages claim, unless Seller is in possession of contradictory evidence. For purposes of this section 6.03, Force Majeure shall include, without limitation, acts of God, changes to applicable laws and regulations, strikes, civil unrest or disobedience, lightning, fire, flood, acts of terrorism, washout, storm, breakage or accident to equipment or machinery, and any other causes that are not reasonably within the control of the party so affected; and working day shall be defined as any day, other than Sunday or legal holiday, on which business is normally conducted on the site of the Work.
 2. The Buyer will determine whether the Goods have been delivered ready for installation within the Procurement Contract Times. Assessment of liquidated damages by the Buyer does not waive the Buyer's right to assess or collect additional damages which Buyer may sustain by the failure of the Seller to perform in accordance with the terms of the Procurement Contract.

ARTICLE 7 – PROCUREMENT CONTRACT PRICE

7.01 Buyer will pay Seller for completion of the Goods and Special Services in accordance with the Procurement Contract Documents at the amounts shown in the attached in Section 00 42 26 Price “Proposal.” attached as Exhibit A Price Proposal.

ARTICLE 8 – PAYMENT PROCEDURES

8.01 Submittal and Processing of Payments: Submit Applications for Payment in accordance with the General Conditions. Applications for Payment will be processed by the PCM as provided in the General Conditions.

8.02 The Buyer will make progress payments related to this Procurement Contract for Goods and Special Services.

A. Payment is based on achieving Procurement Contract Milestones described below and the Schedule of Values for these Milestones. Seller will provide a schedule showing when each Application for Payment will be delivered to the PCM for review and approval in accordance with the Procurement Contract Documents, and the anticipated amount of the Application for Payment in accordance with Section 2.08 of 00 72 00 General Conditions.

[Specify milestones and % of Contract Price; to be negotiated with Contractor.]

Milestone	% of contract price

B. Payment will be made for the amount determined per Paragraph 8.02.A, less the total of payments previously made, and less set-offs determined in accordance with the General Conditions.

ARTICLE 9 – SELLER’S REPRESENTATIONS

9.01 The Seller makes the following representations:

- A. The Seller has examined and carefully studied the Procurement Contract Documents and the other related data identified in the Proposal Documents.
- B. The Seller has visited the Point of Destination and the Site and is familiar with and is satisfied as to the general, local, and Site conditions that may impact the cost, process, or furnishing of the Goods and Special Services.
- C. The Seller is familiar with Laws and Regulations that may impact providing Goods and Special Services.

- D. The Seller has considered the:
 - 1. Information known to Seller;
 - 2. Information commonly known to sellers doing business in the locality of the Site;
 - 3. Information and observations obtained from visits to the Site; and
 - 4. The Procurement Contract Documents.
- E. The Seller has considered the items identified in Paragraphs A through D above with respect to the effect of such information, observations, and documents on:
 - 1. The cost, and schedule for providing Goods and Special Services;
 - 2. The means, methods, techniques, sequences, and procedures to be employed by Seller; and
 - 3. Seller's safety programs.
- F. Based on the information and observations referred to in the preceding paragraphs, Seller agrees that no further examinations, investigations, explorations, tests, studies, or data are necessary for providing the Goods and Special Services at the Procurement Contract Price, within the Procurement Contract Times, and in accordance with the other terms and conditions of the Procurement Contract Documents.
- G. The Seller has correlated the information known to the Seller, information and observations obtained from visits to the Site, reports and drawings identified in the Procurement Contract Documents, and all additional examinations, investigations, explorations, tests, studies, and data with the Procurement Contract Documents.
- H. The Seller has given the PCM written notice of all conflicts, errors, ambiguities, or discrepancies that the Seller has discovered in the Procurement Contract Documents, and the written resolution provided by the PCM is acceptable to the Seller.
- I. The Procurement Contract Documents are sufficient to indicate and convey understanding of all terms and conditions for providing the Goods and Special Services.
- J. Seller's entry into this Procurement Contract constitutes an incontrovertible representation by Seller that without exception the Procurement Contract Price in the Agreement is based upon providing the Goods and Special Services required by the Procurement Contract Documents.
- K. Seller represents and acknowledges that Seller has fully read and understands the terms and conditions for eligibility to contract with the Buyer pursuant to Chapter 38 of the City of Pflugerville's Code of Ordinances, all of which are incorporated herein by reference for all purposes, and hereby certifies that Buyer is currently in compliance with these local requirements and shall remain in compliance with the same throughout the duration of this Agreement. Seller further acknowledges that failure to remain in compliance is a material breach of this Agreement.
- L. Seller represents and acknowledges that the Seller does not boycott Israel and will not boycott Israel during the term of this Agreement.

ARTICLE 10 – PROCUREMENT CONTRACT DOCUMENTS

10.01 Contents:

- A. The Procurement Contract Documents consist of the following:
 - 1. Specifications, forms, and documents listed in Section 00 01 10 “Table of Contents” except as specifically excluded in Paragraph **10.02**.
 - 2. Drawings listed in **Section 00 01 15 “List of Drawings.”**
 - 3. Addenda (Numbers 00 91 01 to 00 91 **[04]**, inclusive).
 - a. Addendum No. 1 issued November 9, 2018
 - b. Addendum No. 2 issued November 16, 2018
 - c. Addendum No. 3 issued November 16, 2018
 - d. Addendum No. 4 issued November 20, 2018
 - 4. Documentation required by the Procurement Contract Documents and submitted by Seller prior to Notice of Award and including Price Proposal; 00 42 23 Proposal Form; 00 45 01 Compliance to State Law on Nonresident Bidders; 00 45 02 Compliance to State Sales Tax Code; 00 45 03 Conflict of Interest Questionnaire; 00 45 04 Non-Collusion Affidavit; 00 45 17 Technical Requirements and Attachments 1 through 10 to 00 45 17; 00 61 13 Performance Bond and 00 61 16 Payment Bond all included in Exhibit B.
- B. The following are also Procurement Contract Documents which may be delivered or issued on or after the Effective Date of the Procurement Contract:
 - 1. Notice to Proceed.
 - 2. Contract Amendment(s).
 - 3. Change Order(s).
 - 4. Field Order(s).
 - 5. Change Directive(s).
- C. There are no Procurement Contract Documents other than those listed above in this Paragraph. The Procurement Contract Documents may only be amended, modified, or supplemented as provided in the General Conditions.

10.02 Proposal Requirements:

- A. The following Proposal Requirements are not Procurement Contract Documents:

Section	Title
00 11 19	Request for Proposals
00 21 16	Instructions to Offerors

Section	Title
00 45 16	Qualifications Statement

ARTICLE 11 LIMITATION OF LIABILITY AND WAIVER OF CONSEQUENTIAL DAMAGES

11.01 Limitation of Liability and Waiver of Consequential Damages

To the extent permissible by applicable law, with the exception of (i) damages awarded respective to Seller’s indemnity obligations under provisions 5.03, 5.04, 5.06, 5.07, 5.11, 5.12, 7.08 and 13.02 of the General Conditions (00 72 00) or (ii) other claims covered by Seller’s insurance to the limits defined in 00 72 01 Item 1.01, Seller shall have no further liability in connection with this Agreement in excess of the cost of correcting any defects, or in the absence of any defect, in excess of the value of the equipment supplied hereunder. However, notwithstanding any other provision of the Agreement to the contrary, in no event shall Seller or Buyer be liable for any punitive, exemplary, special, incidental, or consequential loss or damage suffered by the other party in connection with this Agreement.

These limits shall not apply to third party claims based on injury, death, or property damage. For the purpose of this term, the equipment provided in accordance with the requirements of this project shall not be considered property and shall instead be covered under the terms of the warranty herein. These limits shall not apply to claims which are based on the willful misconduct, gross negligence, or fraud of the Seller.

The Effective Date of the Procurement Contract is _____.

Buyer: _____
(typed or printed)

Seller: _____
(typed or printed)

By: _____
(individual's signature)

By: _____
(individual's signature)

Name: _____
(typed or printed)

Name: _____
(typed or printed)

Title: _____
(typed or printed)

Title: _____
(typed or printed)

(Attach evidence of authority to sign.)

Address for giving notice:

City of Pflugerville, Texas
100 E Main Street, Suite 100
Pflugerville, TX 78691-0589

Address for giving notice:

Designated representative:

Name: _____

Designated representative:

Name: _____

Title: _____

Title: _____

Address: _____

Address: _____

Phone: _____

Phone: _____

Email: _____

Email: _____

END OF SECTION

00 01 10 TABLE OF CONTENTS

Section	Title
Division 00	Procurement and Contracting Requirements
00 01 10	Table of Contents
00 01 15	List of Drawings
00 42 23	Proposal Form
00 42 26	Price Proposal
00 43 13	Bid Bond
00 45 01	Compliance to State Law on Nonresident Bidders
00 45 02	Compliance to State Sales Tax Code
00 45 03	Conflict of Interest Questionnaire
00 45 04	Non-Collusion Certification
00 45 05	Prohibition on Contracts with Companies Boycotting Israel
00 45 16	Technical Proposal
00 45 17	Technical Requirements
00 52 23	Agreement
00 61 13	Performance Bond
00 61 16	Payment Bond
00 72 00	General Conditions
00 72 01	Insurance Requirements
00 73 00	Supplementary Conditions
Division 01	General Requirements
01 11 00	Summary of Work
01 29 00	Application for Payment Procedures
01 31 00	Project Management and Coordination
01 31 13	Project Coordination
01 31 14	Change Management
01 33 00	Document Management
01 33 02	Shop Drawings
01 33 04	Operation and Maintenance Data
01 64 10	Contractor Installed Goods and Special Services

Section	Title
01 70 00	Execution and Closeout Requirements
01 75 00	Starting and Adjusting
01 78 36	Warranties and Service Agreements
01 79 00	Training of Operation and Maintenance Personnel
Division 26	Electrical
26 05 19	Wires and Cables (1000 Volts and Above)
26 05 33	Raceway, Boxes, and fittings
26 05 50	NEMA Frame Induction Motors, 600 volts and below
26 24 19	Low Voltage Motor Control Centers
26 29 86	Mechanical Manufacturer's Provided Control Panels (MEMs)
26 43 13	Low Voltage AC Surge Protective Devices (SPDs)
Division 46	Process Equipment
46 53 61.01	Carousel Style Biological Nutrient Removal (BNR) System Retrofit (Phase II)

END OF SECTION

00 01 15 LIST OF DRAWINGS

Sheet No.	Sheet Title
01	Site Plan

END OF SECTION

EXHIBIT A

EXHIBIT A

PRICE PROPOSAL-PHASE 2

ARTICLE 1: PRICE PROPOSAL FOR PHASE 2 BIOLOGICAL NUTRIENT REMOVAL (BNR) PROCESS EQUIPMENT FOR THE CITY OF PFLUGERVILLE WASTEWATER TREATMENT FACILITY EXPANSION AND UPGRADE PROJECT.

- 1.01 To: City of Pflugerville
100 East Main Street, Suite 100
Pflugerville, TX 78660
- 1.02 The undersigned Offeror proposes to furnish all equipment as described in 46 53 61.01 Carousel Style Biological Nutrient Removal (BNR) System (Phase 2)
- 1.03 The undersigned declares that it is the Offeror or by holding the position below indicated is authorized to execute this Price Proposal on behalf of the Offeror and that all representations made on this Price Proposal are true and correct
- 1.04 The undersigned acknowledges that the Price Proposal is based on the requirements of the RFP and as amended by any Addenda during the procurement period and accepts the terms and conditions contained in this Price Proposal.

ARTICLE 2: EQUIPMENT PRICE

- 2.01 Offeror will provide the equipment described in 46 53 61.01 Carousel Style Biological Nutrient Removal (BNR) System (Phase 2).
- 2.02 Phase 2 Price
- A. Phase 2: The Lump Sum amount of One Million Five Hundred And Five Thousand Six Hundred Ninety one (in words).
\$ 1,505,691 (numerical).
1. ("Base Price" Phase 2 Equipment). This amount shall be used in the Price Adjustment Methodology described in Article 3 below

ARTICLE 3: PRICE ADJUSTMENT METHODOLOGY

- 3.01 On the date that the Phase 2 equipment purchase order ("Equipment Purchase Order Date") is received by the Seller, the Buyer will pay the lesser of: (1) the amount calculated using the Price Adjustment Methodology described below or (2) the more recent of (a) sale price of similar equipment made within 90 days of the Equipment Purchase Order Date in a competitive environment or (b) pending offer made in a competitive environment. The information related to (2) (a) or (b) will be provided by Seller to Buyer in a certified letter which will include the price and other evidence and information as appropriate as to meeting the requirements of this Section. To avoid any doubt, Buyer will pay the lesser amount of (1), (2)(a) or (2)(b).
- 3.02 Price Adjustment Methodology

- A. The price adjustment methodology will be based on the following indices from the U. S. Department of Labor, Bureau of Labor Statistics (BLS)- Producer Price Index (PPI), and Consumer Price Index (CCI):
1. Stainless Steel (“SS”) = Commodity Data PPI: 10250466 – Nickel, Nickel base allow mill shape
 2. Other Material (“OM”) = Industry Data PPI: 3339 – General Purpose Machinery Manufacturing
 3. Motors (“M”) = Industry Data PPI: 335312 – Motor and Generator Manufacturing
 4. Electrical Equipment (“EE”) = Industry Data PPI: 335313 – Switchgear and Switchboard Apparatus Manufacturing
 5. Other Services (“OS”) = Consumer Price Index: All Urban Consumers, Urban, Professional Services, South
- B. The Supplier’s equipment price will be allocated to no more than 5 PPI/CPIs to characterize the best representation of the separate components that comprise the goods and services. By way of example the table below will describe this concept

ARTICLE 4: SELLER PRICE COMPONENTS	% of Total Cost	Indices
Stainless Steel (“SS”)	8%	PPI Index - SS:
Other Material (“OM”)	32%	PPI Index -OM:
Motors (“M”)	20%	PPI Index- M:
Electrical Equipment (“EE”)	30%	PPI Index -EE:
Other Services (“OS”)	10%	PPI- OS:
Total Cost (“Base Price”)	100%	

Formula to be used to adjust Base Price to the Adjusted Price at a Future Date

Adjusted Price = (Base Price x .08) (PPI-SS on Purchase Order Date/PPI-SS Base Price Date) + (Base Price x .32) (PPI-OM Purchase Order Date/PPI-OM Base Price Date) + (Base Price x .20) (PPI-M Purchase Order Date/PPI-M Base Price Date) + (Base Price x .30) (PPI-EE Purchase Order Date/PPI-EE Base Price Date) + (Base Price x .10) (PPI- OS Index Purchase Order Date/PPI- OS Base Price Date)

4.01 Assignment of Agreement to Construction Contractor

- A. The Agreement that will be executed between the Buyer and Seller will be assigned to the Phase 2 Contractor. The assignment will occur currently with the execution of the construction agreement by the Buyer with the Phase 2 Contractor.
- B. Phase 2 Contractor shall have Equipment Purchase Order Dates in the assignment which will require that the Equipment Purchase Order be placed on or before the Equipment Purchase Order Date. If the Phase 2 Contractor fail to meet this requirement, the Phase 2 Contractor shall be responsible for any additional costs and expenses.

ARTICLE 5: ACKNOWLEDGEMENT

OFFEROR AND SELLER NAME: OVIVO UDSA, LLC

Name of Individual

Title

Signature

Date

EXHIBIT B



00 42 23 PROPOSAL FORM

ARTICLE 1 – PROPOSAL RECIPIENT

- 1.01 This Proposal is submitted to:
 - City of Pflugerville, Texas
 - Central Wastewater Treatment Plant Expansion
 - Biological Nutrient Removal (BNR) Process Equipment – Solicitation #2019-5

ARTICLE 2 – OFFEROR’S ACKNOWLEDGMENTS

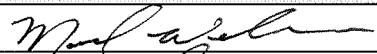
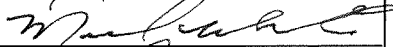
- 2.01 Offeror proposes and agrees, if this Proposal is accepted, to enter into an Agreement with Buyer on the form included in the Procurement Contract Documents, to provide Goods and Special Services specified or indicated in Procurement Contract Documents for the Procurement Contract Price indicated in this Proposal or as modified by Contract Amendment. Offeror agrees to provide Goods and Special Services within the Procurement Contract Times established in the Agreement or as modified by Contract Amendment and comply with the all other terms and conditions of the Procurement Contract Documents.
- 2.02 Offeror accepts all of the terms and conditions of the Request for Proposals and Instructions to Offerors, including those dealing with required bonds. The Proposal will remain subject to acceptance for 90 days after the date of Proposal submission.
- 2.03 Offeror accepts the provisions of the Agreement as to liquidated damages in the event of its failure to provide Goods and Special Services in accordance with the schedule set forth in the Agreement.
- 2.04 Offeror acknowledges receipt of the following Addenda:

Addendum No.	Addendum Date	Signature Acknowledging Receipt
1	11/09/18	
2	11/16/18	
3	11/16/18	
4	11/20/18	

ARTICLE 3 – OFFEROR’S REPRESENTATIONS

- 3.01 The Offeror has examined and carefully studied the Procurement Contract Documents and the other related data identified in the Proposal Documents.
- 3.02 The Offeror has become familiar with and is satisfied as to the general, local, and Site conditions that may impact providing Goods and Special Services.
- 3.03 The Offeror is familiar with Laws and Regulations that may impact providing Goods and Special Services.
- 3.04 The Offeror has considered the:
 - A. Information known to Offeror;
 - B. Information commonly known to Sellers doing business in the area of Site; and
 - C. The Procurement Contract Documents.

- 3.05 Based on the information and observations referred to in the preceding paragraphs, Offeror agrees that no further examinations, investigations, explorations, tests, studies, or data are necessary for providing Goods and Special Services at the Procurement Contract Price, within the Procurement Contract Times, and in accordance with the other terms and conditions of the Procurement Contract Documents.
- 3.06 The submission of a Proposal will constitute an incontrovertible representation by the Offeror that the Offeror has complied with every requirement of this Section, that without exception the Proposal is premised upon completion of provisions of Goods and Special Services required by the Procurement Contract Documents, Addenda and the related supplemental data, that the Offeror has given the PCM written notice of all conflicts, errors, ambiguities and discrepancies that the Offeror has discovered in the Procurement Contract Documents, Addenda and the related supplemental data and the written resolutions provided by the PCM are acceptable to the Offeror, and that the Procurement Contract Documents, Addenda and the related supplemental data are generally sufficient to indicate and convey understanding of all terms and conditions for providing the Goods and Special Services.
- 3.07 The Offeror is aware of the general nature of construction to be performed by Buyer, Contractor, and others at the Site that relates to providing Goods and Special Services as indicated in the Procurement Contract Documents.
- 3.08 The Offeror has correlated the information known to the Offeror, information and observations obtained from visits to the Site, reports and drawings identified in the Procurement Contract Documents, and all additional examinations, investigations, explorations, tests, studies, and data with the Procurement Contract Documents.
- 3.09 The Offeror has given the PCM written notice of all conflicts, errors, ambiguities, or discrepancies that the Offeror has discovered in the Procurement Contract Documents, and the written resolution provided by the PCM is acceptable to the Offeror.
- 3.10 The Procurement Contract Documents are generally sufficient to indicate and convey understanding of all terms and conditions for providing Goods and Special Services.
- 3.11 Offeror's entry into this Procurement Contract constitutes an incontrovertible representation by Offeror that without exception all prices in the Agreement are premised upon providing the Goods and Special Services required by the Procurement Contract Documents.

ARTICLE 4 – BASIS OF OFFER

- A. Offeror will provide the Goods and Special Services in accordance with the Procurement Contract Documents for the prices shown in the attached in Section 00 42 26 "Price Proposal."
- B. Unit prices offered include the Procurement Contract Price for providing Goods and Special Services related to the award of only those Goods covered in line items as shown in Section 00 42 26 "Price Proposal."

ARTICLE 5 – TIME OF COMPLETION

- 5.01 Offeror agrees that the Goods will be complete, delivered to the Site ready for assembly and installation by the Contractor per the technical specification.

- 5.02 Offeror agrees that Special Services will be provided within 30 days after receiving notice from the Contractor that the equipment will be ready to be placed in operation in accordance with the Procurement Contract Documents.

ARTICLE 6 – ATTACHMENTS TO THIS PROPOSAL

- 6.01 The following documents are attached to and made a condition of this Proposal:
- A. Section 00 42 26 “Price Proposal”;
 - B. Section 00 43 13 “Bid Bond”;
 - C. Section 00 45 01 “Compliance to State Law on Nonresident Bidders”;
 - D. Section 00 45 02 “Compliance to State Sales Tax Code”;
 - E. Section 00 45 03 “Conflict of Interest Questionnaire”;
 - F. Section 00 45 04 “Non-Collusion Affidavit”;
 - G. Section 00 45 05 “Prohibition on Contracts with Companies Boycotting Israel”;
 - H. Section 00 45 16 “Technical Proposal”;
 - I. Section 00 45 17 “Technical Proposal Requirements” and required attachments.

ARTICLE 7 – DEFINED TERMS

- 7.01 The terms used in this Proposal have the meanings indicated in the General Conditions and the Supplementary Conditions. The significance of terms with initial capital letters is described in the General Conditions.

ARTICLE 8 – VENUE

- 8.01 Offeror agrees that venue lies exclusively in Travis County, Texas for any legal action.

ARTICLE 9 – PROPOSAL SUBMITTAL

9.01 This Proposal is submitted by:

Offeror: Ovivo USA, LLC
(typed or printed name of organization)

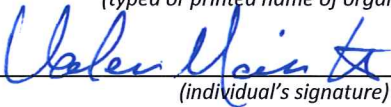
Signature: 
(individual's signature)

Name: Valere Morissette
(typed or printed)

Title: Senior Vice President, North America
(typed or printed)

Address for giving notices:

Ovivo USA, LLC
2404 Rutland Drive
Austin, TX 78758

Phone: 512-834-6000 Email: valere.morissette@ovivowater.com

(Attach evidence of authority to sign if Offeror is a corporation, partnership, or a joint venture.)

END OF SECTION

00 45 01 COMPLIANCE TO STATE LAW ON NONRESIDENT BIDDERS

Texas Government Code Chapter 2252 applies to the award of government contract to nonresident bidders. This chapter provides that:

“a government entity may not award a governmental contract to a nonresident bidder unless the nonresident underbids the lower bid submitted by a responsible resident bidder by an amount that is not less than the amount by which a resident bidder would be required to underbid the nonresident bidder to obtain a comparable contract in the state in which the nonresident’s principal place of business is located.”

“Nonresident bidder” refers to a person who is not a resident of Texas.

“Resident bidder” refers to a person whose principal place of business is in this state, including a contractor whose ultimate parent company or majority owner has its principal place of business in this state.

Check the statement that is correct for Offeror:

- Offeror (includes parent company or majority owner) qualifies as a resident bidder whose principal place of business is in the state of Texas.
- Offeror qualifies as a nonresident bidder whose principal place of business or residency is in the state of: _____

Any determination of state bidder preference law is based on the Texas Comptroller’s annual summary of other state bidder preference laws. For the purpose of this determination, Offerors submitting a Proposal are considered to be Bidders.

Offeror: _____
(typed or printed name of organization)

Signature: _____
(individual’s signature)

Name: _____
(typed or printed)

Title: _____
(typed or printed)

Business Address:

Ovivo USA, LLC

2404 Rutland Drive

Austin, TX 78758

Phone: 512-834-6000 Email: valere.morissette@ovivowater.com

(Attach evidence of authority to sign if Offeror is a corporation, partnership, or a joint venture.)

END OF SECTION

00 45 02 COMPLIANCE TO STATE SALES TAX CODE

Comply with all applicable sales, excise, and use tax requirements of the Texas Tax Code. The Offeror hereby certifies that the Procurement Contract Price is divided as follows:

Tax exempt products, materials, and services (See Notes 1 and 2)	\$ 0.00
Taxable products, materials, and services (See Note 3)	\$ 0.00
Total (See Note 4)	\$ 0.00

Offeror: Ovivo USA, LLC
(typed or printed name of organization)

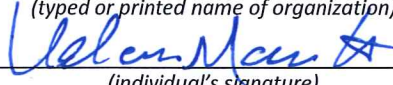
Signature: 
(individual's signature)

Name: Valere Morisette
(typed or printed)

Title: Senior Vice President, North America
(typed or printed)

Business Address:
Ovivo USA, LLC
2404 Rutland Drive
Austin, TX 78758

Phone: 512-834-6000 Email: valere.morisette@ovivowater.com
(Attach evidence of authority to sign if Offeror is a corporation, partnership, or a joint venture.)

Notes:

1. Exempt products and materials are those items purchased for the Project which are physically incorporated into the facilities constructed for the Buyer or are necessary and essential for providing Goods and Special Services and are completely consumed for the Project. For purposes of this definition, products and materials are completely consumed if after being used once for its intended purpose it is used up or destroyed. Products and materials rented or leased for use in providing Goods and Special Services cannot be completely consumed for the purposes of this definition.
2. Exempt services are those services performed at the Site where the Procurement Contract expressly requires the specific service to be provided or purchased by the person performing the service is integral to providing Goods and Special Services.
3. Products, materials, and services are not tax exempt if they are used by the Seller but are not physically incorporated into the Buyer's facilities or are not consumed by construction or installation as defined above. Machinery or equipment and its accessories and repair and replacement parts used in providing Goods and Special Services are not exempt.
4. The total sum of the amount for tax exempt and taxable products, materials, and services must equal the Procurement Contract Price.

END OF SECTION

CONFLICT OF INTEREST QUESTIONNAIRE		FORM CIQ
For vendor doing business with local governmental entity		
<p>This questionnaire reflects changes made to the law by H.B. 23, 84th Leg., Regular Session.</p> <p>This questionnaire is being filed in accordance with Chapter 176 of the Local Government Code by a vendor who has a business relationship as defined by Section 176.001(1-a) with a local governmental entity and the vendor meets requirements under Section 176.006(a).</p> <p>By law this questionnaire must be filed with the records administrator of the local governmental entity not later than the 7th business day after the date the vendor becomes aware of facts that require the statement to be filed. See Section 176.006(a-1), Local Government Code.</p> <p>A vendor commits an offense if the vendor knowingly violates Section 176.006, Local Government Code. An offense under this section is a misdemeanor.</p>		OFFICE USE ONLY
		Date Received
1	Name of vendor who has a business relationship with local governmental entity.	
2	<input type="checkbox"/> Check this box if you are filing an update to a previously filed questionnaire. (The law requires that you file an updated completed questionnaire with the appropriate filing authority not later than the 7th business day after the date on which you became aware that the originally filed questionnaire was incomplete or inaccurate.)	
3	Name of local government officer about whom the information is being disclosed.	
<hr style="width: 50%; margin: auto;"/> Name of Officer		
4	Describe each employment or other business relationship with the local government officer, or a family member of the officer, as described by Section 176.003(a)(2)(A). Also describe any family relationship with the local government officer. Complete subparts A and B for each employment or business relationship described. Attach additional pages to this Form CIQ as necessary.	
<p>A. Is the local government officer or a family member of the officer receiving or likely to receive taxable income, other than investment income, from the vendor?</p> <p><input type="checkbox"/> Yes <input type="checkbox"/> No</p> <p>B. Is the vendor receiving or likely to receive taxable income, other than investment income, from or at the direction of the local government officer or a family member of the officer AND the taxable income is not received from the local governmental entity?</p> <p><input type="checkbox"/> Yes <input type="checkbox"/> No</p>		
5	Describe each employment or business relationship that the vendor named in Section 1 maintains with a corporation or other business entity with respect to which the local government officer serves as an officer or director, or holds an ownership interest of one percent or more.	
6	<input type="checkbox"/> Check this box if the vendor has given the local government officer or a family member of the officer one or more gifts as described in Section 176.003(a)(2)(B), excluding gifts described in Section 176.003(a-1)	
7	<hr style="width: 50%; margin: auto;"/> Signature of vendor doing business with the governmental entity	<hr style="width: 50%; margin: auto;"/> Date

CONFLICT OF INTEREST QUESTIONNAIRE
For vendor doing business with local governmental entity

A complete copy of Chapter 176 of the Local Government Code may be found at <http://www.statutes.legis.state.tx.us/Docs/LG/htm/LG.176.htm>. For easy reference, below are some of the sections cited on this form.

Local Government Code § 176.001(1-a): "Business relationship" means a connection between two or more parties based on commercial activity of one of the parties. The term does not include a connection based on:

- (A) a transaction that is subject to rate or fee regulation by a federal, state, or local governmental entity or an agency of a federal, state, or local governmental entity;
- (B) a transaction conducted at a price and subject to terms available to the public; or
- (C) a purchase or lease of goods or services from a person that is chartered by a state or federal agency and that is subject to regular examination by, and reporting to, that agency.

Local Government Code § 176.003(a)(2)(A) and (B):

(a) A local government officer shall file a conflicts disclosure statement with respect to a vendor if:

(2) the vendor:

(A) has an employment or other business relationship with the local government officer or a family member of the officer that results in the officer or family member receiving taxable income, other than investment income, that exceeds \$2,500 during the 12-month period preceding the date that the officer becomes aware that

- (i) a contract between the local governmental entity and vendor has been executed;
- or
- (ii) the local governmental entity is considering entering into a contract with the vendor;

(B) has given to the local government officer or a family member of the officer one or more gifts that have an aggregate value of more than \$100 in the 12-month period preceding the date the officer becomes aware that:

- (i) a contract between the local governmental entity and vendor has been executed; or
- (ii) the local governmental entity is considering entering into a contract with the vendor.

Local Government Code § 176.006(a) and (a-1)

(a) A vendor shall file a completed conflict of interest questionnaire if the vendor has a business relationship with a local governmental entity and:

- (1) has an employment or other business relationship with a local government officer of that local governmental entity, or a family member of the officer, described by Section 176.003(a)(2)(A);
- (2) has given a local government officer of that local governmental entity, or a family member of the officer, one or more gifts with the aggregate value specified by Section 176.003(a)(2)(B), excluding any gift described by Section 176.003(a-1); or
- (3) has a family relationship with a local government officer of that local governmental entity.

(a-1) The completed conflict of interest questionnaire must be filed with the appropriate records administrator not later than the seventh business day after the later of:

(1) the date that the vendor:

(A) begins discussions or negotiations to enter into a contract with the local governmental entity; or

(B) submits to the local governmental entity an application, response to a request for proposals or bids, correspondence, or another writing related to a potential contract with the local governmental entity; or

(2) the date the vendor becomes aware:

(A) of an employment or other business relationship with a local government officer, or a family member of the officer, described by Subsection (a);

(B) that the vendor has given one or more gifts described by Subsection (a); or

(C) of a family relationship with a local government officer.

END OF SECTION

00 45 04 NON-COLLUSION CERTIFICATION

STATE OF Texas

COUNTY OF Travis

Buyer: **City of Pflugerville**
PO Box 589
Pflugerville, TX 78691

Contract: **Central WWTP Expansion**
Equipment Procurement – BNR Process Equipment
PFL16607

Offeror certifies that it has not been a party to any collusion among Offerors in the restraint of freedom of competition by agreement to submit a Bid or Proposal at a fixed price or to refrain from submitting a Bid or Proposal; or with any official or employee of the Buyer as to quantity, quality, or price in the prospective contract, or any other terms of said prospective contract; or in any discussion between Offerors and any official of the Buyer concerning exchange of money or other thing of value for special consideration in the letting of a contract.

Offeror: Ovivo USA, LLC
(typed or printed name of organization)

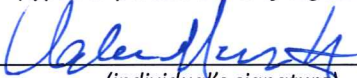
Signature: 
(individual's signature)

Name: Valere Morisette
(typed or printed)

Title: Senior Vice President, North America
(typed or printed)

Business Address:

Ovivo USA, LLC
2404 Rutland Drive
Austin, TX 78758

Phone: 512-834-6000 Email: valere.morisette@ovivowater.com

(Attach evidence of authority to sign if Offeror is a corporation, partnership, or a joint venture.)

END OF SECTION

TECHNICAL REQUIREMENTS – 00 45 17 – PROPOSAL FORM 4 (2.04 F)

Seller: Ovivo USA, LLC

Project: Procurement Package Biological Nutrient Removal (BNR) Process Equipment

Item	Description	Attachment No.
1	Complete description of all equipment offered, including catalogs, cut sheets, and pertinent design data.	1
2	List of deviations between Seller’s offered Goods and the products specified.	2
3	Drawings of equipment and appurtenances showing dimensions, size and layout of connections (piping and electrical), weight, anchorage requirements, clearance requirements, and other pertinent design details. This includes but is not limited to: (1) to-scale basin plan drawings showing the location of all major equipment and instrumentation in PDF and CAD. (2) To-scale basin section/elevation drawings identifying basin and equipment depths and water levels in PDF and CAD. (3) Process and instrumentation diagrams of BNR System.	3
4	Technical data on products and process for protective coatings and linings.	4
5	Location of facilities for manufacturing (foundry, machining and assembly) and factory witness testing.	5
6	Plan and schedule indicating dates for submittals, manufacturing, testing, and delivery.	6
7	Letter acknowledging that Seller will meet specified Warranty Requirements.	7
8	List of spare parts to be provided and included in the prices stated in the Price Proposal.	8
9	Resume of proposed Seller’s Project Manager.	9
10	Resume of proposed Seller’s Representative for Installation Checks and Startup Services.	10
11	Resume of Seller’s Representative for Training.	11

SCOPE OF SUPPLY

For Phase 1 of the Pflugerville, TX Central WWTP Expansion Ovivo has provided two separate options.

BASE Option 1 is the AlternatIR process featuring a deep tank approach allowing for an overall footprint of 268' x 130' for the new equipment train. This option matches what Freese and Nichols as well as the City of Pflugerville have seen throughout the design phase:

A2C ~~Option 2 is the A2C process featuring the anoxic and aerobic tank approach allowing for an overall footprint of 290' x 135' for the new equipment train.~~

BASE
~~OPTION 1~~

~~PHASE 1~~

- (2) 150 HP Excell Aerator II Aerators	- (2) Motor Control Centers
- (2) 150 HP LSA Aerators w/draft tubes	- (1) System Control Panel
- (6) or (10) Submersible Mixers	- Instrumentation
- (2) EliminatIR Gates	

PHASE 2

- | | |
|---|-----------------------------|
| - (4) 150 HP Excell Aerator II Aerators | - (2) Motor Control Centers |
| - (6) or (10) Submersible Mixers | - (1) System Control Panel |
| - (2) EliminatIR Gates | - Instrumentation |

A2C
1

~~OPTION 2~~

~~PHASE 1~~

- | | |
|---|-----------------------------|
| - (4) 150 HP Excell Aerator II Aerators | - (2) Motor Control Centers |
| - (8) or (12) Submersible Mixers | - (1) System Control Panel |
| - (2) EliminatIR Gates | - Instrumentation |

~~PHASE 2~~

- | | |
|---|-----------------------------|
| - (4) 150 HP Excell Aerator II Aerators | - (2) Motor Control Centers |
| - (6) or (10) Submersible Mixers | - (1) System Control Panel |
| - (2) EliminatIR Gates | - Instrumentation |

AERATORS

ITEMS INCLUDED per Aerator:

- | | |
|---|---|
| - 150 HP motor including: | - Gearbox including: |
| - 460 Volt, 3 phase, 60 hertz duty | - 2.0 service factor (minimum) |
| - TEFC | - High speed flexible coupling |
| - Mill and chemical duty preparation | - Low speed coupling (cast iron) |
| - Nominal 1800 rpm output | - Independent lower bearing |
| - 1.0/1.15 SF inverter duty/sine wave power | - Oil drain |
| - Class F insulation | - Mechanical oil pump |
| - Motor thermal protection device | - Dip Stick |
| - Motor space heater | - Low oil Pressure switch |
| - Premium efficiency | - Immersion heater |
| - Mounting plate/bars (A36) | - Surface aerator impeller (304/304L SS) |
| - Assembly bolts (A325) | - Surface aerator impeller shaft (A36) |
| - Nameplate (stainless steel) | - (4) jack studs (Zinc plated) |
| - See SURFACE PREPARATION AND PAINTING | - Service as noted in the FIELD SERVICE segment |

- Freight, FCA factory, freight allowed to jobsite.

ADDITIONAL ITEMS INCLUDED:

- Velocity testing

~~BASE
Option 1 - Phase 1
(2) Draft tubes (A36) - (2) Lower turbines and shafts (A36)~~

BASE
Option 1 - Phase 2
- (4) Submerged radial pumping turbines and shafts (A36)

~~A2C
Option 2 - Phase 1
- (4) Submerged radial pumping turbines and shafts (A36)
A2C
Option 2 - Phase 2
- (4) Submerged radial pumping turbines and shafts (A36)~~

NOTE: Ovivo is proposing that the installing contractor form and pour the partition wall extension and Excell Velocity Enhancer in concrete. Ovivo will coordinate required dimensions with Freese and Nichols to ensure contract documents indicate requirements for construction and estimation purposes for both Phase 1 and Phase 2.

APPROXIMATE TOTAL WEIGHT OF ONE (1) MECHANISM: 8,400 LBS.
APPROXIMATE WEIGHT OF HEAVIEST SINGLE COMPONENT: 3,746 LBS.

SUBMERSIBLE MIXERS

ITEMS INCLUDED per Submersible Mixer:

- Motor (Appropriate size) including:
 - 460 volts, 3 phase, 60 hertz duty
 - Watertight, submersible rated
 - Class F insulation
 - Thermal switches
 - Power cable (30')
 - Cast Iron housing
- Mount/rail assembly (304 SS)
- Manual lifting device (304 SS) with cable (SS)
- Freight, FCA factory, freight allowed to job site
- Service as noted in the FIELD SERVICE segment
- Planetary gearbox including:
 - Spline connection
 - Sealed oil chamber
 - Cast iron housing
 - Appropriate output rpm
 - Non clogging propeller (PUR)
 - Assembly/anchor bolts (304 SS)
 - Nameplate (SS)
- See SURFACE PREPARATION AND PAINTING
- Operation and Maintenance manuals

APPROXIMATE TOTAL WEIGHT OF ONE (1) MECHANISM: 1,200 LBS.
APPROXIMATE WEIGHT OF HEAVIEST SINGLE COMPONENT: 700 LBS.

ELIMINAT/IR GATES

ITEMS INCLUDED per Gate:

- Actuator, including:
 - 460 volt/3 phase/ 60 hertz motor
 - Worm gear reducer
 - Absolute position encoder
 - Electronic torque sensor
- Bearings (UHMW PE)
- See SURFACE PREPARATION AND PAINTING
- Freight, FCA factory, freight allowed to job site
- Stand (A36)
- Stem and shaft (304 SS)
- Turning vane (304 SS)
- Anchor bolts (304 SS)
- Assembly fasteners (304 SS)
- Operation and Maintenance manuals
- Service as noted in the FIELD SERVICE segment

APPROXIMATE TOTAL WEIGHT OF ONE (1) MECHANISM: 1,200 LBS.

APPROXIMATE WEIGHT OF HEAVIEST SINGLE COMPONENT: 700 LBS.

MOTOR CONTROL CENTER

ITEMS INCLUDED per Motor Control Center:

- MCC Cabinet, including:
 - NEMA 1A enclosure
 - Main disconnect
 - 120/240 lighting panel
 - FVNR motor starters as required, including:
 - Circuit breaker disconnect
 - 120V control transformer
 - Contactor
 - 30mm operators (as required)
 - EliminatIR Gate breaker, including:
 - Circuit breaker disconnect
- (2) HD 150hp 6 Pulse VFDs, including:
 - Door disconnect
 - Molded case circuit breaker
 - Control power transformer
 - Digital operator interface
 - Ethernet option board
 - 30mm operators (as required)
 - Line filter
 - Load reactor

SYSTEM CONTROL PANEL

ITEMS INCLUDED per Control Panel:

- PLC Controller Section, including:
 - 316 SS NEMA 4X Enclosure
 - ControLogix PLC Controller
 - 15in HMI
 - Ethernet Switch
 - Terminal Blocks (as required)
 - Control Relays (as required)
 - 120V Surge Suppression
 - Analog Surge Suppression (as required)
 - 120V Programming Receptacle
 - Remote Access Device

INSTRUMENTATION

ITEMS INCLUDED (with Instrumentation) – PER BASIN:

- (3) Hach SC200 Analyzers, each including:
 - NEMA 4X enclosure
 - Handrail mounting bracket
 - Sun shield
- (2) Hach LDO Probes, including:
 - Luminescent technology
 - Mounting hardware
 - Molded cable
- 1 (1) Hach ORP Probe(s), including:
 - Differential electrode technology
 - Mounting hardware

ITEMS NOT INCLUDED WITH CARROUSEL SYSTEM (But not limited to the following):

- Installation.
- Vibration analysis testing
- Oxygen transfer testing
- Bypass with across the line starter (internal)
- dV/dT Filter
- External Wiring and Conduit
- Power Factor Correction Capacitors (PFCC)
- Tools, Warning signs, Oils/Lubricants
- Permits, fees, samples, testing
- Harmonic Testing
- Conformal Coatings
- Pushbutton stations
- Panel mounting components
- Field wiring/installation
- Bridges, walkways, stairs, ladders, handrail
- Mist shields or curtains
- Slide gates or sluice gates
- Grout

SPARE PARTS:

PHASE 1 AND PHASE 2 (LOT OF SPARES PROVIDED FOR EACH PHASE OF THE PROJECT)

- Aerators
 - (1) High speed flexible coupling
 - (3) High speed flexible coupling inserts
 - (1) Oil sensing cutout switch
- Mixers
 - (1) Set of bearings, mechanical seals and o-rings for each mixer provided
- Control Panels
 - (6) Replacement fuses, all types and sizes
 - (1) Starter coil for each NEMA size furnished
- Motor Control Center
 - (3) Control fuses of each type used (1) Replacement lamp of each color for pilot lights
 - (1) Replacement lens of each color for pilot lights
 - (12) Cover bolts, spring nuts and door fasteners.
 - (1) Quart of touch up paint

FIELD SERVICE:

- Our proposal includes the service of a qualified service engineer for the following:
 - 28 Days / 8 Trips at the site to assist in adjusting, servicing, and checking out these mechanisms, and in training the operators in maintenance, troubleshooting, and repair of the equipment.
 - Additional service days can be purchased at the current rate

SURFACE PREPARATION AND PAINT

- Submerged and non-submerged fabricated steel shall be shop-cleaned per SSPC-SP-10 and shop primed 1 coat of Tnemec 161-1211 (3.0 to 5.0 Mils D.F.T). Stainless steel will not receive a coating.
- Motors and gear reducers shall receive manufactures standard surface preparation. Shop priming and painting shall consist of a high quality coating that is specifically resistant to chemical, solvent, salt water, and acid environmental conditions.
- The entire body of the submersible mixer assembly shall be abrasive blasted to SSPC-SP 10 with a minimum 2.5 mil profile. The mixer shall then be immediately coated with a minimum of 15 mils of ceramic compound consisting of a two-part polymer/ceramic design including reinforcing with special fillers and extenders.

1. DELIVERY

Ovivo will submit drawings for approval within **eight (8)** weeks after Purchaser's receipt of Ovivo's written acknowledgement of an approved purchase order. Ovivo intends to ship all Products **twenty-eight (28)** weeks after receipt of approved drawings from Purchaser.

2. STORAGE AND CARE PRIOR TO INSTALLATION

The Contractor shall store and temporarily support equipment prior to installation. Protect all exposed surfaces. Keep records of the storage parameters and the dates that storage procedures were performed. The Contractor shall be responsible for work, equipment, and materials until inspected, tested and finally accepted.

Store gear reducers, motors, VFD's and control system components in buildings or trailers which have a concrete or wooden floor, a roof and fully closed walls on all sides. Protect the equipment from being contaminated by dust, dirt, vibration and moisture.

Temporarily connect equipment with built in space heaters to a power source and keep heaters in operation. Rotate all shafts that have bearings on at least a monthly basis.

3. INSTALLATION OF EQUIPMENT

Ovivo shall provide installation manuals to the installing contractor 30 days prior to the shipment of the equipment. The installation manuals and detailed erection drawings will outline proven methods of installation. Ovivo will also provide checklists to the Contractor detailing specific items of interest that must be completed prior to the testing and startup of the equipment.

4. TESTING AND STARTUP

Ovivo shall furnish the services of a factory representative who has complete knowledge of proper operating and maintenance to inspect the final installation and supervise a test run of the equipment. The test runs on the mechanical aerators shall be undertaken with water in the aeration tanks filled up to the high water elevation shown on the contract drawings.

The Contractor/Owner shall be responsible for providing sufficient water, or treated wastewater for filling the tanks for the test runs on the aerators. The test runs on the aerators shall confirm acceptable normal running noise, speed, vibration and direction.

After the aerator is installed and aligned, and Ovivo's recommendations for initial start-up have been implemented, the aerator shall be run at full speed and full load for a minimum of two hours after the oil temperature has stabilized. The gear reducer housing and shaft seals shall be checked for leakage of lubricant. Any leaks shall be corrected and the temperature rise of the lubricant in the oil sump of the gear reducer shall not exceed 100°F above ambient.

In the event of improper installation, the Contractor shall be responsible for the correction of the work and subsequent test runs until the defects are corrected.

5. AERATOR PERFORMANCE VALIDATION

Ovivo will certify power and submit oxygen rates (lb/hr) vs speed curves. Ovivo will submit third-party (Stenstrom, Rosso, or Redmon) clean water testing on the impellers from a similar site drawing the same HP (150 HP) per specifications. If it is desired to have oxygen transfer tests specific to the Pflugerville aerators and basins, this may be arranged at additional cost. For

the clean water test, the city would have to supply potable water for the tests, and dispose of chemical-laden water following the test. The mixed liquor steady state test could also be done, although this test is not recognized by ASCE.

6. BUYER TRAINING

Ovivo will provide the buyer with training on the operation and maintenance of the equipment at the time of equipment commissioning. Ovivo will coordinate schedules with the buyer to allow sufficient advanced notice prior to equipment startup and commissioning. In our experience this training is most effective on site and demonstrated on the actual equipment done by the field service engineer.

Ovivo will also provide process training to the waste water treatment plant operators after the plant has been in operation for 60 days allowing the process to fully develop.

7. O&M MANUALS

O&M manuals will be provided in digital/searchable PDF format prior to operator training provided by Ovivo.

8. SPARE PARTS INVENTORY

Ovivo and its partnered suppliers maintain common spare parts in inventory, available for immediate shipment. Recommended spare parts are listed in Proposal Form 4 – Attachment 8 and are included in this scope of supply. Additional components that may require replacement are either in stock or may have a short lead time.

9. WARRANTY SERVICES

Ovivo shall warrant all equipment furnished for a period of one year against defects in materials and workmanship and operational failure for a period of 24 months after equipment startup or 36 months after the delivery of the equipment, whichever occurs first.

10. ADDITIONAL INFORMATION (see introductory pages of this section)

Vertical AC Motors

1HP - 700 HP

140T - 5010 FRAMES

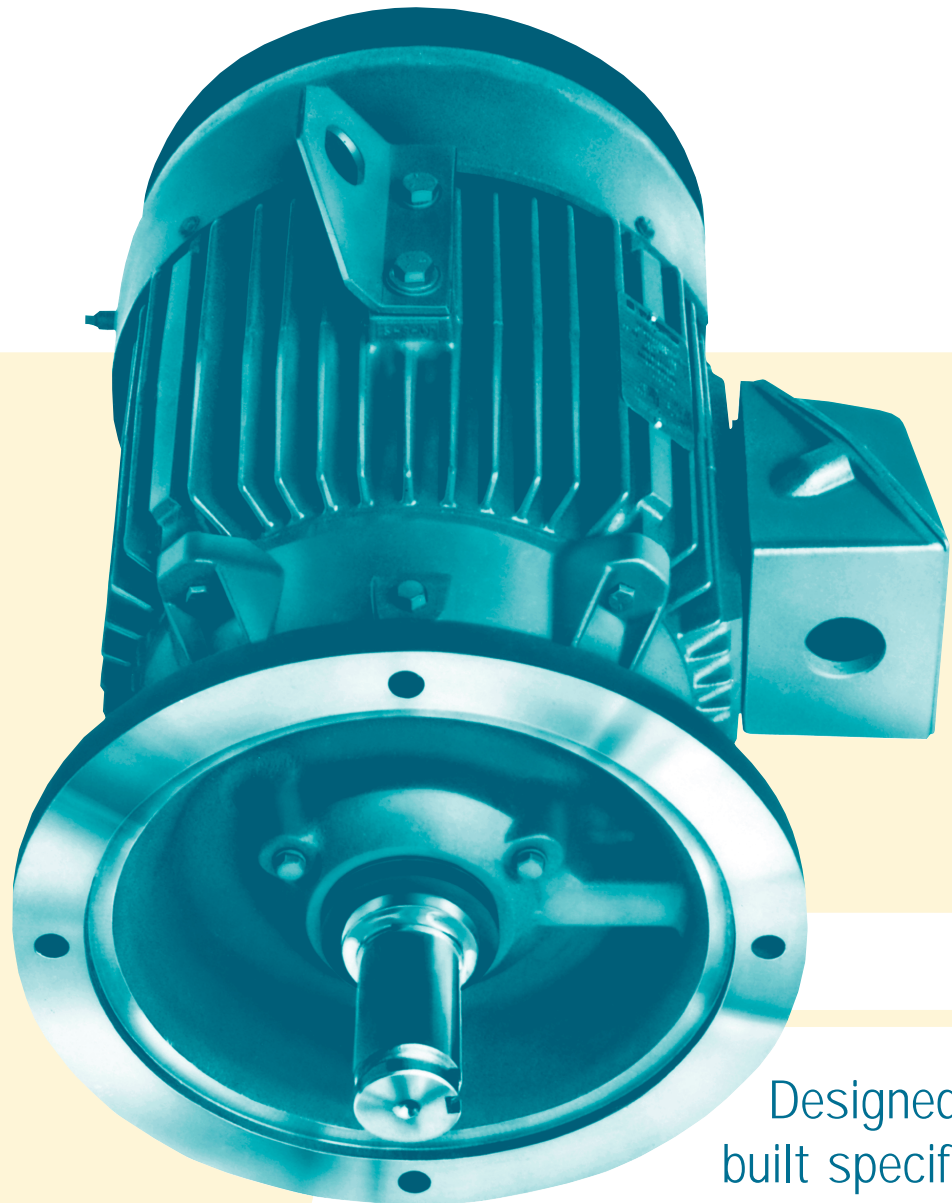

Designed and
built specifically
for vertical service!

Duty Master Vertical AC Motors

Applications

Duty Master Vertical AC motors are the perfect power mates for centrifugal pumps, sump pumps, turbine pumps, in-line process pumps, fans, aerators, mixers, autoclaves, cooling towers and similar applications in general industrial environments.

Additional performance and protection features are available in standard modification packages for customized applications in special environments such as petroleum refining, chemical, processing and water treatment. Reliance In-Line NEMA LP motors are designed to meet the American Petroleum Institute Standard 610.

Efficiency

There is no need to limit your energy savings to horizontal applications. Significant energy savings and short pay-back periods are also available to you for vertical applications.

Reliance Vertical AC motors are available in premium efficient, XE designs. The same engineering and manufacturing knowledge and experience that go into every horizontal Reliance Electric



A clear water feed pump in a paper processing operation is driven by a Weather-Protected NEMA type 1 Duty Master Vertical Motor.

XE motor also go into every Reliance Vertical XE motor produced. The XE design is capable of inverter operation at 1.0 S.F. For selection and application assistance, call your local Rockwell Automation Sales Engineer.

Enclosures

Duty Master Vertical AC motors are available in a variety of enclosures and thrust values to suit your application.

All frames are cast iron. For the harshest industrial environments, we offer an extra tough (XT) mechanical package especially designed to meet the challenges of severe applications. Premium features protect motor components from chemicals, corrosion, and abrasives, extending motor life and improving performance. Reliance Vertical AC motors are also available with special Arctic Duty motor construction. This enables the motors to operate successfully in temperatures down to -60° C. Arctic Duty Vertical motor construction is available in 182T through 449T with UL listing for Class 1, Groups C and D, and through 5000 frame with non-UL Listed construction.

Duty Master Vertical AC motors are available for normal thrust, NEMA HP, normal thrust above NEMA, medium thrust and extended thrust in-line NEMA LP ratings. All motors are manufactured to tolerances which meet or exceed NEMA requirements in every frame size and horsepower rating. Just choose the frame size, horsepower and environmental protection you need from this guide.

That's all it takes to put the motor specifically built for vertical service into your application where normal, medium or high thrust capability is required.

Enclosure	HP Range	Frame size
TEFC, TEFC-XP	1-400	180-449
TEFC	150-400	447-5010
ODP, WPI, WPPI	100-700	447-5010

Insulation

A full Class F insulation system consisting of Class F and H materials extends motor life by providing extra protection against high thermal and electrical shock. A full Class H system is available for higher thermal requirements.

Vacuum Pressure Impregnation (VPI) is available in both NEMA and above NEMA frame sizes. The exclusive VPI system, which provides a sealed insulation system, is used in wet, humid, and contaminant-laden conditions.

Form wound or medium voltage motors define three levels for VPI sealed systems. The standard SolidCure system is one VPI cycle while the SolidSeal system uses two VPI cycles plus additional insulation materials and processes to deliver a sealed insulation system in accordance with both IEEE429 and NEMA MG1-20.49.1. The Enduraseal® system is made with the same materials and processes as the SolidSeal system, except each and every Enduraseal® winding receives and passes a water immersion test.

Insulation and Bearings

Bearings

Bearing life is related to load as well as to correct handling and assembly procedures. Reliance Electric motors are designed with special care to utilize proper bearing sizes to ensure that motors are capable of handling continuous up or down thrust conditions. Quality control and assembly procedures are adhered to during the manufacturing process to minimize factors that tend to shorten bearing life. All NEMA frame bearing sizes provide a minimum two year L-10 life. Refer to

table below for complete thrust capacities with bearing life for NEMA frame sizes.

The standard normal thrust bearing system uses deep groove, single-row ball bearings. The standard in-line NEMA LP system uses a pair of angular contact, single-row ball bearings mounted back to back to carry the thrust load. The bearing construction meets the requirements of A.P.I. Std. 610. The above NEMA high thrust bearing system uses angular contact ball bearings (single-row, duplex

single-row, tandem single-row) and spherical roller bearings. All ball bearings are made with vacuum degassed steel for three times life factor, and are suitable for temperatures up to 250°F (121° C). Single-row ball bearings meet AFBMA C-3 specifications for internal clearances.



Duty Master XT Vertical Motors drive in-line process pumps in petroleum refining operation.

HP & LP THRUST CAPABILITIES L-10 BEARING LIFE DOWN THRUST IN POUNDS

RPM	FRAME SIZE	HP THRUST					LP MEDIUM THRUST					LP EXTENDED THRUST				
		1YR	2YR	3YR	50K HRS	100K HRS	1YR	2YR	3YR	50K HRS	100K HRS	1YR	2YR	3YR	50K HRS	100K HRS
3600	180	140	100	80	50	30	730	570	490	390	300					
	210	200	140	110	70	40	980	770	660	520	400					
	250	640	470	390	280	200	1520	1190	1030	820	640	2470	1950	1700	1360	1060
	280	730	530	440	320	220	1850	1450	1260	1000	780	3030	2390	2080	1660	1300
	320	810	590	480	340	230	1800	1400	1210	950	730	2980	2340	2030	1610	1250
	360	1010	720	580	410	270	2190	1710	1470	1150	880	3630	2840	2460	1950	1520
	400	970	680	540	370	230	2150	1660	1430	1110	840	3580	2800	2420	1910	1470
	440	890	600	460	290	140	2050	1560	1330	1010	740	3500	2720	2340	1830	1390
	447/9	690	400	260			1850	1360	1130	810	540	3300	2520	2140	1630	1190
1800	180	200	140	110	80	40	930	720	630	500	380					
	210	290	200	160	110	70	1250	980	850	670	520					
	250	860	620	520	380	270	1910	1500	1300	1040	810	3120	2460	2140	1710	1340
	280	990	710	590	430	300	2330	1830	1590	1260	980	3820	3010	2620	2090	1640
	320	1091	770	630	450	300	2260	1760	1520	1190	910	3750	2940	2550	2020	1570
	360	1370	980	810	570	380	2780	2160	1870	1470	1120	4580	3600	3120	2480	1920
	400	1280	890	720	480	290	4490	3510	3030	2390	1830	7550	5930	5140	4090	3190
	440	1130	740	570	330	140	4340	3360	2880	2240	1680	7400	5780	4990	3940	3040
	447/9	780	390	220			3990	3010	2530	1890	1330	7050	5430	4640	3590	2690
1200	180	260	190	160	110	80	1080	850	740	590	460					
	210	360	260	210	150	100	1450	1140	990	790	610					
	250	1010	730	610	450	310	2180	1720	1490	1180	920	3560	2810	2440	1950	1530
	280	1160	840	690	510	350	2670	2090	1810	1440	1120	4370	3440	2990	2390	1870
	320	1290	920	750	540	360	2600	2020	1740	1370	1050	4300	3370	2920	2320	1800
	360	1640	1160	950	680	450	3180	2480	2130	1680	1280	5250	4120	3570	2830	2200
	400	1540	1070	850	580	360	5150	4020	3470	2740	2100	8640	6790	5890	4690	3660
	440	1390	910	700	430	200	4980	3850	3300	2570	1930	8470	6620	5720	4520	3490
	447/9	1090	610	400			4680	3550	3000	2270	1630	8170	6320	5420	4220	3190
900	180	300	220	180	130	90	1190	940	810	650	510					
	210	410	300	240	170	120	1590	1250	1090	870	680					
	250	1140	840	700	510	370	2410	1900	1650	1310	1020	3930	3100	2700	2160	1700
	280	1330	980	800	590	420	2960	2320	2020	1610	1250	4830	3810	3320	2650	2080
	320	1490	1080	890	650	450	2910	2270	1970	1560	1200	4780	3760	3270	2600	2030
	360	1860	1340	1100	800	540	3530	2750	2370	1870	1440	5800	4560	3950	3140	2450
	400	1780	1250	1010	710	450	5710	4470	3860	3050	2360	9560	7520	6530	5210	4070
	440	1600	1080	840	540	280	5540	4300	3690	2880	2190	9390	7350	6360	5040	3900
	447/9	1130	600	360			5070	3830	3220	2410	1720	8920	6880	5890	4570	3430



Typical NEMA Frame Construction

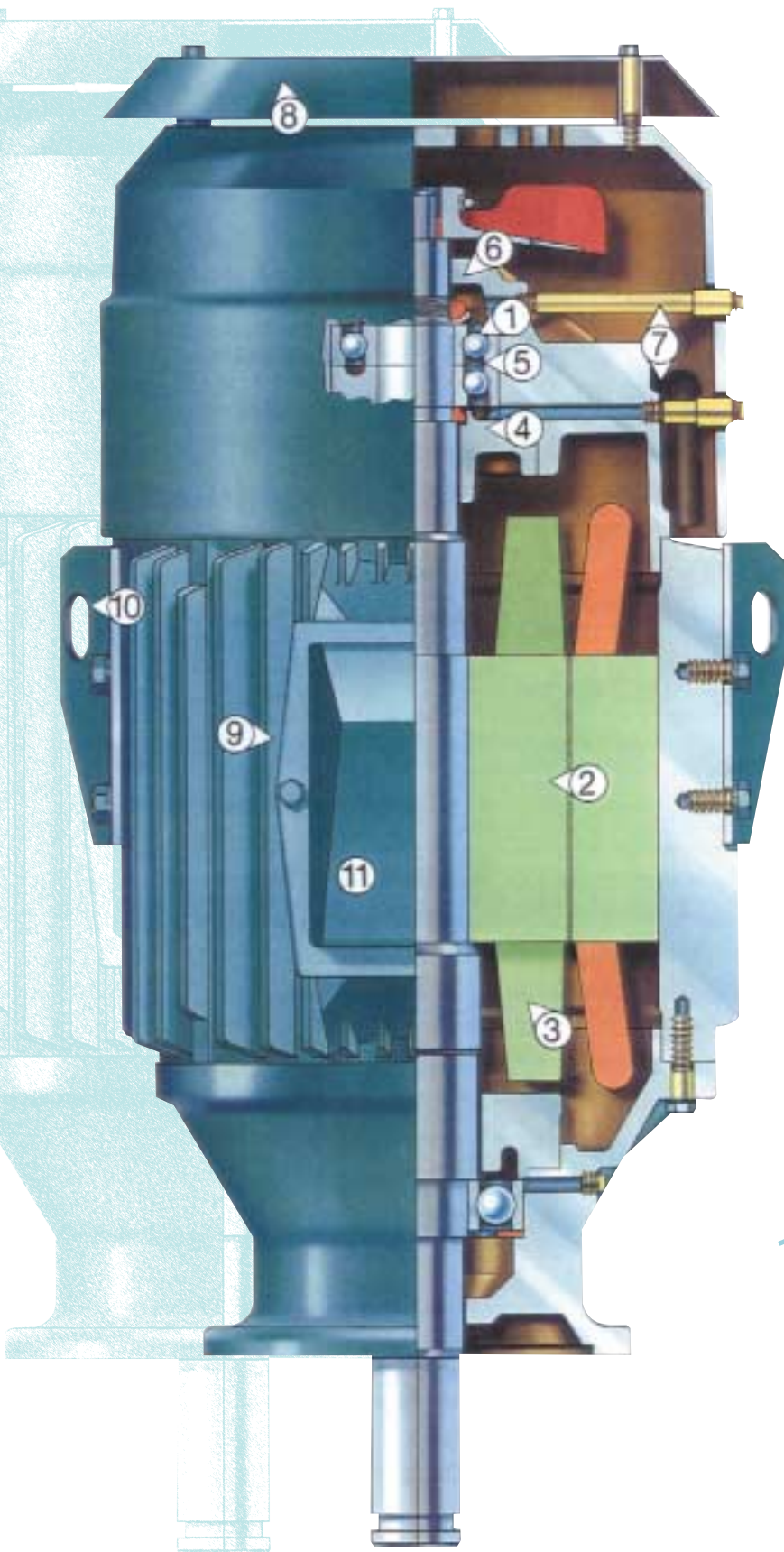

1 Top mounted bearing in NEMA LP designs meets the requirements of A.P.I. Spec. # 610.

2 High-grade steel laminations of rotor and stator reduce current densities and losses for greater electrical efficiency.

3 Integrally cast rotor fins provide rapid heat dissipation to assure cool operation for longer life.

4 Bearing cap clamps bearing system in sturdy bracket to help eliminate end play and extend life of both motor and driven equipment.

5 Thrust bearing is designed to withstand upward and downward thrust to minimize shaft movement.

6 Large grease reservoir is located above bearing to assure proper lubrication for maximum motor life.

7 Grease relief occurs by purging through bearing for positive lubrication.

8 Drip cover extends motor life by preventing rain, snow or falling objects from entering motor.

9 Standard conduit box is diagonally split for fast installation and easy servicing; can be rotated for connection from top, bottom, or either side.

10 Steel lifting plates bolted on the frame of totally enclosed fan-cooled enclosures simplify motor lifting per NEMA requirements.

11 Provision for grounding in the conduit box is standard in all frame sizes; assures a positive ground for all electrical connections.

Lubrication & Advanced Technology

Lubrication

Grease entry passages are located above both the thrust and guide bearings to ensure positive lubrication of the motor. Old grease is purged through grease relief passages.

Each motor is pre-lubricated with grease proven superior for electric motor service. The grease contains corrosion inhibitors and operates effectively through a temperature range of -15°F to $+300^{\circ}\text{F}$. Special high and low temperature greases are also available for special applications.

When thrust conditions and bearing selection on above NEMA frames require the use of oil lubrication, it will be provided as standard. Oil lubrication is available on above NEMA frames for other than standard conditions.



One of eight Reliance vertical P-Base motors in use at a wastewater treatment plant.

Advanced Engineering Technology

As a value added manufacturer of modifiable motors for more than 90 years, we are committed to optimizing motor dependability and energy conservation through advanced motor design. We add value in electrical performance, material selection and testing. We add value through advanced manufacturing processes as well as through proper application of our motors to meet your requirements. Every Reliance Electric motor is manufactured in a plant using stringent ISO 9001 certified quality control procedures.

Comprehensive testing and quality control procedures ensure compliance with a broad range of industrial performance standards including NEMA, IEEE, and UL.

Many options are available to customize your motor to meet specific application requirements. Space heaters, thermal overloads, and extra-tough features are just a few of the options available.

Find Out More

To find out how Reliance Electric products can help you meet the productivity and performance demands of your application, contact your Rockwell Automation Sales Engineer .

Visit us on-line to obtain the latest information about Reliance Electric products and services.

<http://www.reliance.com>

Reed Frequency Testing

Reed frequency analysis plays a key role in the successful application of vertical machines. The motor reed frequency, as obtained from the motor alone on the seismic mass, along with the motor mass and its location, can be used by the customer as inputs to his system model, in order to better predict equipment behavior during operation. In order to provide accurate data on resonance and vibration, we have equipped our test facilities with apparatus such as seismic bases and modern instrumentation to provide:

- **Structural modal analysis**
- **Vibration spectrum analysis**
- **Resonance frequency analysis**

Reed frequency testing is conducted at the state-of-the-art, Advanced Development Laboratory at Rockwell Automation headquarters in Greenville, SC. This testing and research facility expands our ability to provide quality motor products to meet the growing technological needs of our customers.



This state-of-the-art laboratory is located in Greenville, SC

Reach us now at www.rockwellautomation.com

Rockwell Automation, a business of Rockwell International Corporation (NYSE: ROK), brings together leading brands in industrial automation, including Dodge mechanical power transmission products, Reliance Electric motors and drives, Allen-Bradley controls and Rockwell Software. Rockwell Automation's unique Complete Automation™ approach to helping customers achieve a competitive advantage is supported by thousands of authorized partners, distributors and solution providers around the world.



Headquarters for Dodge and Reliance Electric

Americas

Rockwell Automation
 6040 Ponders Court
 Greenville, SC 29615-4617 USA
 Tel: (1) 864.297.4800
 Fax: (1) 864.281.2433

Europe

Rockwell Automation
 Brühlstraße 22
 D-74834 Elztal-Dallau
 Germany
 Tel: (49) 6261 9410
 Fax: (49) 6261 941-122

Asia Pacific

Rockwell Automation
 55 Newton Rd.
 #11-01/02 Revenue House
 Singapore 307987
 Tel: (65) 351.6723
 Fax: (65) 355.1733

Headquarters for Allen-Bradley and Rockwell Software

Americas

Rockwell Automation
 1201 South Second Street
 Milwaukee, WI 53204-2496 USA
 Tel: (1) 414.382.2000
 Fax: (1) 414.382.4444

Europe

Rockwell Automation
 SA/NV
 Boulevard du Souverain 36
 1170 Brussels, Belgium
 Tel: (32) 2 663 06 00
 Fax: (32) 2 663 06 40

Asia Pacific

Rockwell Automation
 27/F Citicorp Centre
 18 Whitfield Road
 Causeway Bay, Hong Kong
 Tel: (852) 2887 4788
 Fax: (852) 2887 1846



Single Speed Motor Submittal Data

The Reliance Electric motor(s) proposed for this project will be as shown on the detailed dimensional drawing and will have the characteristics shown on the motor data sheet(s) enclosed with this package. Additionally, the motor(s) will have the following construction features:

- TEFC (Totally Enclosed, Fan-Cooled) Enclosure
- Vertical construction with a canopy cap (drip cover) and suitable lifting lugs
- Rated for VFD duty at a maximum 2:1 speed reduction with proper VFD location
- Rated for constant torque service
- Premium efficiency
- Rated at 40° C ambient with Class F insulation and Class B temperature rise at full load
- Service factor of 1.15 on sine wave power
- Service factor of 1.0 on VFD power
- ABMA L₁₀ bearing life of 200,000 hours
- All cast iron construction, Mill & Chemical, Corro-duty or Severe Duty rating
- Vertical P-Base (LP medium thrust)
- Suitable for operation in a moisture-laden atmosphere
- Finish painted at the factory with a corrosion-resistant paint
- Gasketed conduit boxes
- Stainless steel condensation drains
- Grease-lubricated ball bearings with flushing capabilities
- Winding end turns dipped and baked with a non-hygroscopic varnish
- Stator bores and rotor cores with epoxy paint
- Stainless steel nameplates
- Space heaters
- Normally closed thermostatic heat protection
- NEMA design B

Insulation and Bearings

Bearings

Bearing life is related to load as well as to correct handling and assembly procedures. Reliance Electric motors are designed with special care to utilize proper bearing sizes to ensure that motors are capable of handling continuous up or down thrust conditions. Quality control and assembly procedures are adhered to during the manufacturing process to minimize factors that tend to shorten bearing life. All NEMA frame bearing sizes provide a minimum two year L-10 life. Refer to

table below for complete thrust capacities with bearing life for NEMA frame sizes.

The standard normal thrust bearing system uses deep groove, single-row ball bearings. The standard in-line NEMA LP system uses a pair of angular contact, single-row ball bearings mounted back to back to carry the thrust load. The bearing construction meets the requirements of A.P.I. Std. 610. The above NEMA high thrust bearing system uses angular contact ball bearings (single-row, duplex

single-row, tandem single-row) and spherical roller bearings. All ball bearings are made with vacuum degassed steel for three times life factor, and are suitable for temperatures up to 250°F (121° C). Single-row ball bearings meet AFBMA C-3 specifications for internal clearances.



Duty Master XT Vertical Motors drive in-line process pumps in petroleum refining operation.

HP & LP THRUST CAPABILITIES L-10 BEARING LIFE DOWN THRUST IN POUNDS

RPM	FRAME SIZE	HP THRUST					LP MEDIUM THRUST					LP EXTENDED THRUST				
		1YR	2YR	3YR	50K HRS	100K HRS	1YR	2YR	3YR	50K HRS	100K HRS	1YR	2YR	3YR	50K HRS	100K HRS
3600	180	140	100	80	50	30	730	570	490	390	300					
	210	200	140	110	70	40	980	770	660	520	400					
	250	640	470	390	280	200	1520	1190	1030	820	640	2470	1950	1700	1360	1060
	280	730	530	440	320	220	1850	1450	1260	1000	780	3030	2390	2080	1660	1300
	320	810	590	480	340	230	1800	1400	1210	950	730	2980	2340	2030	1610	1250
	360	1010	720	580	410	270	2190	1710	1470	1150	880	3630	2840	2460	1950	1520
	400	970	680	540	370	230	2150	1660	1430	1110	840	3580	2800	2420	1910	1470
	440	890	600	460	290	140	2050	1560	1330	1010	740	3500	2720	2340	1830	1390
	447/9	690	400	260			1850	1360	1130	810	540	3300	2520	2140	1630	1190
1800	180	200	140	110	80	40	930	720	630	500	380					
	210	290	200	160	110	70	1250	980	850	670	520					
	250	860	620	520	380	270	1910	1500	1300	1040	810	3120	2460	2140	1710	1340
	280	990	710	590	430	300	2330	1830	1590	1260	980	3820	3010	2620	2090	1640
	320	1091	770	630	450	300	2260	1760	1520	1190	910	3750	2940	2550	2020	1570
	360	1370	980	810	570	380	2780	2160	1870	1470	1120	4580	3600	3120	2480	1920
	400	1280	890	720	480	290	4490	3510	3030	2390	1830	7550	5930	5140	4090	3190
	440	1130	740	570	330	140	4340	3360	2880	2240	1680	7400	5780	4990	3940	3040
	447/9	780	390	220			3990	3010	2530	1890	1330	7050	5430	4640	3590	2690
1200	180	260	190	160	110	80	1080	850	740	590	460					
	210	360	260	210	150	100	1450	1140	990	790	610					
	250	1010	730	610	450	310	2180	1720	1490	1180	920	3560	2810	2440	1950	1530
	280	1160	840	690	510	350	2670	2090	1810	1440	1120	4370	3440	2990	2390	1870
	320	1290	920	750	540	360	2600	2020	1740	1370	1050	4300	3370	2920	2320	1800
	360	1640	1160	950	680	450	3180	2480	2130	1680	1280	5250	4120	3570	2830	2200
	400	1540	1070	850	580	360	5150	4020	3470	2740	2100	8640	6790	5890	4690	3660
	440	1390	910	700	430	200	4980	3850	3300	2570	1930	8470	6620	5720	4520	3490
	447/9	1090	610	400			4680	3550	3000	2270	1630	8170	6320	5420	4220	3190
900	180	300	220	180	130	90	1190	940	810	650	510					
	210	410	300	240	170	120	1590	1250	1090	870	680					
	250	1140	840	700	510	370	2410	1900	1650	1310	1020	3930	3100	2700	2160	1700
	280	1330	980	800	590	420	2960	2320	2020	1610	1250	4830	3810	3320	2650	2080
	320	1490	1080	890	650	450	2910	2270	1970	1560	1200	4780	3760	3270	2600	2030
	360	1860	1340	1100	800	540	3530	2750	2370	1870	1440	5800	4560	3950	3140	2450
	400	1780	1250	1010	710	450	5710	4470	3860	3050	2360	9560	7520	6530	5210	4070
	440	1600	1080	840	540	280	5540	4300	3690	2880	2190	9390	7350	6360	5040	3900
	447/9	1130	600	360			5070	3830	3220	2410	1720	8920	6880	5890	4570	3430



REL. S.O.	FRAME	HP	TYPE	PHASE/ HERTZ	RPM	VOLTS
	445LP	150	P	3/60	1785	460
AMPS	DUTY	AMB °C/ INSUL.	S.F.	NEMA DESIGN	CODE LETTER	ENCL.
165	CONT	40/F	1.15	B	G	TEFC-XEY
E/S	ROTOR	TEST S.O.	TEST DATE	STATOR RES.@25 °C OHMS (BETWEEN LINES)		
598900	418143035FE	---	---	.0289		
PERFORMANCE						
LOAD	HP	AMPERES	RPM	% POWER FACTOR	% EFFICIENCY	
NO LOAD	0	42.4	1800	4.80	0	
1/4	37.5	57.7	1797	64.8	94.0	
2/4	75.1	88.0	1793	83.3	96.0	
3/4	112	125	1790	87.7	96.4	
4/4	150	165	1786	88.5	96.2	
5/4	187	207	1782	88.3	95.8	
SPEED TORQUE						
		RPM	TORQUE % FULL LOAD	TORQUE LB.-FT.	AMPERES	
LOCKED ROTOR		0	157	692	1085	
PULL UP		700	150	660	1040	
BREAKDOWN		1728	264	1165	625	
FULL LOAD		1786	100	441	165	
<p>AMPERES SHOWN FOR 460. VOLT CONNECTION. IF OTHER VOLTAGE CONNECTIONS ARE AVAILABLE, THE AMPERES WILL VARY INVERSELY WITH THE RATED VOLTAGE</p> <p>REMARKS: XE MOTOR-TYPICAL DATA-NEMA NOM. EFF. 96.2 PCT. GUARANTEED MIN. EFF. 95.8 PCT.</p>						
Rockwell Automation		DR. BY <u>C.R. THOMPSON</u>			A-C MOTOR PERFORMANCE E06845-XCL006 DATA	
		CK. BY <u>K.W. KANOUFF</u>				
APP. BY <u>K.W. KANOUFF</u>			ISSUE DATE 04/21/94			
DATE <u>04/21/94</u>						

REL S.O.
 FRAME 445LP
 HP 150
 TYPE P
 PHASE/HERTZ 3/60

RPM 1785
 VOLTS 460
 AMPS 165
 DUTY CONT
 AMB °C/INSUL 40/F

S.F. 1.15
 NEMA DESIGN B
 CODE LETTER G
 ENCLOSURE TEFC-XEX
 E/S 598900

ROTOR 418143035FE
 TEST S.O. ---
 TEST DATE ---
 STATOR RES. @ 25 °C .0289
 OHMS (BETWEEN LINES)

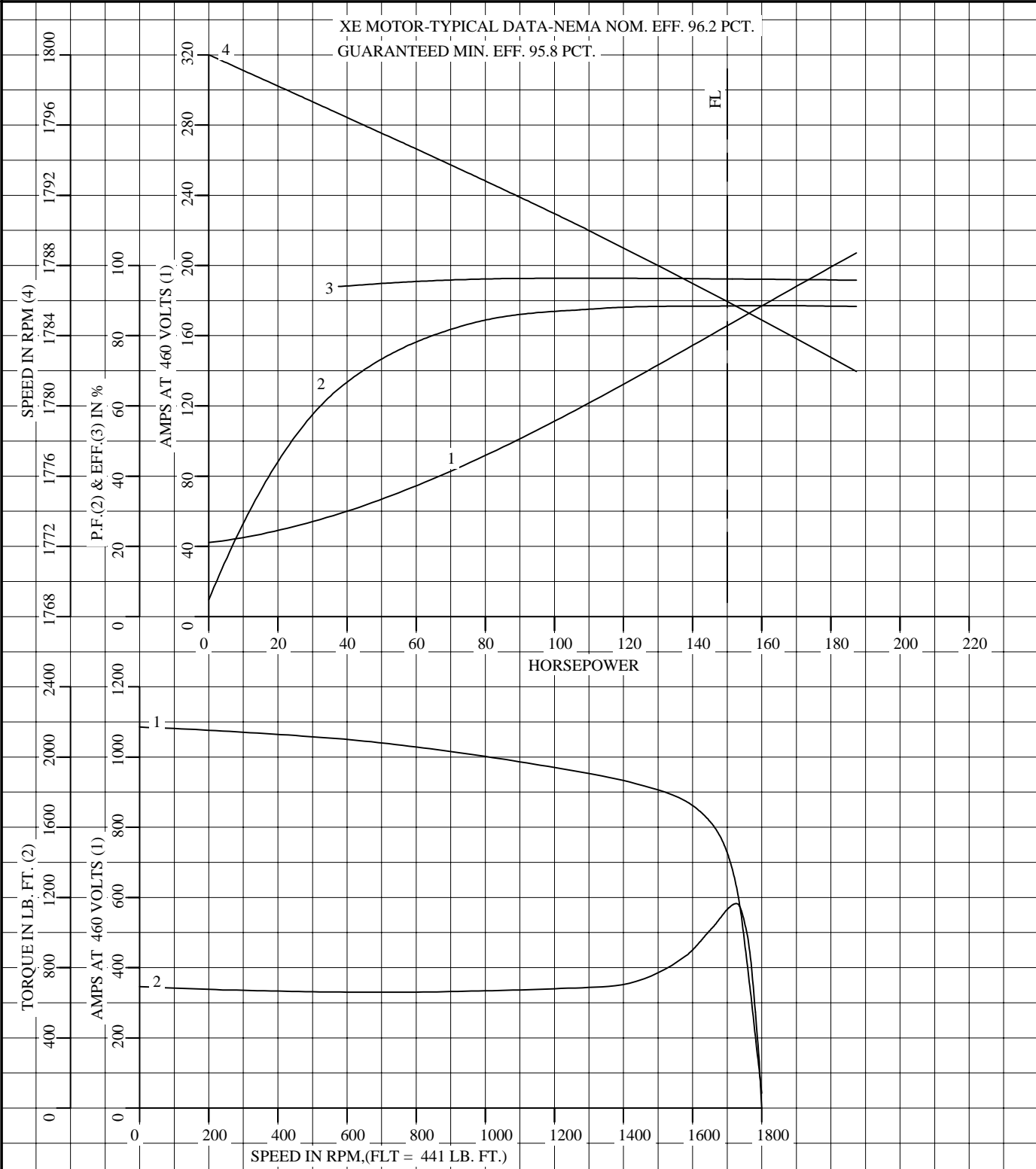

AMPERES SHOWN FOR 460 VOLT CONNECTION, IF OTHER VOLTAGE CONNECTIONS ARE AVAILABLE, THE AMPERES WILL VARY INVERSELY WITH THE RATED VOLTAGE.

Rockwell Automation

DR. BY C.R. THOMPSON
 CK. BY K.W. KANOUFF
 APP. BY K.W. KANOUFF
 DATE 04/21/94

A-C MOTOR PERFORMANCE CURVES
 E06845-XCL006
 ISSUE DATE 04/21/94

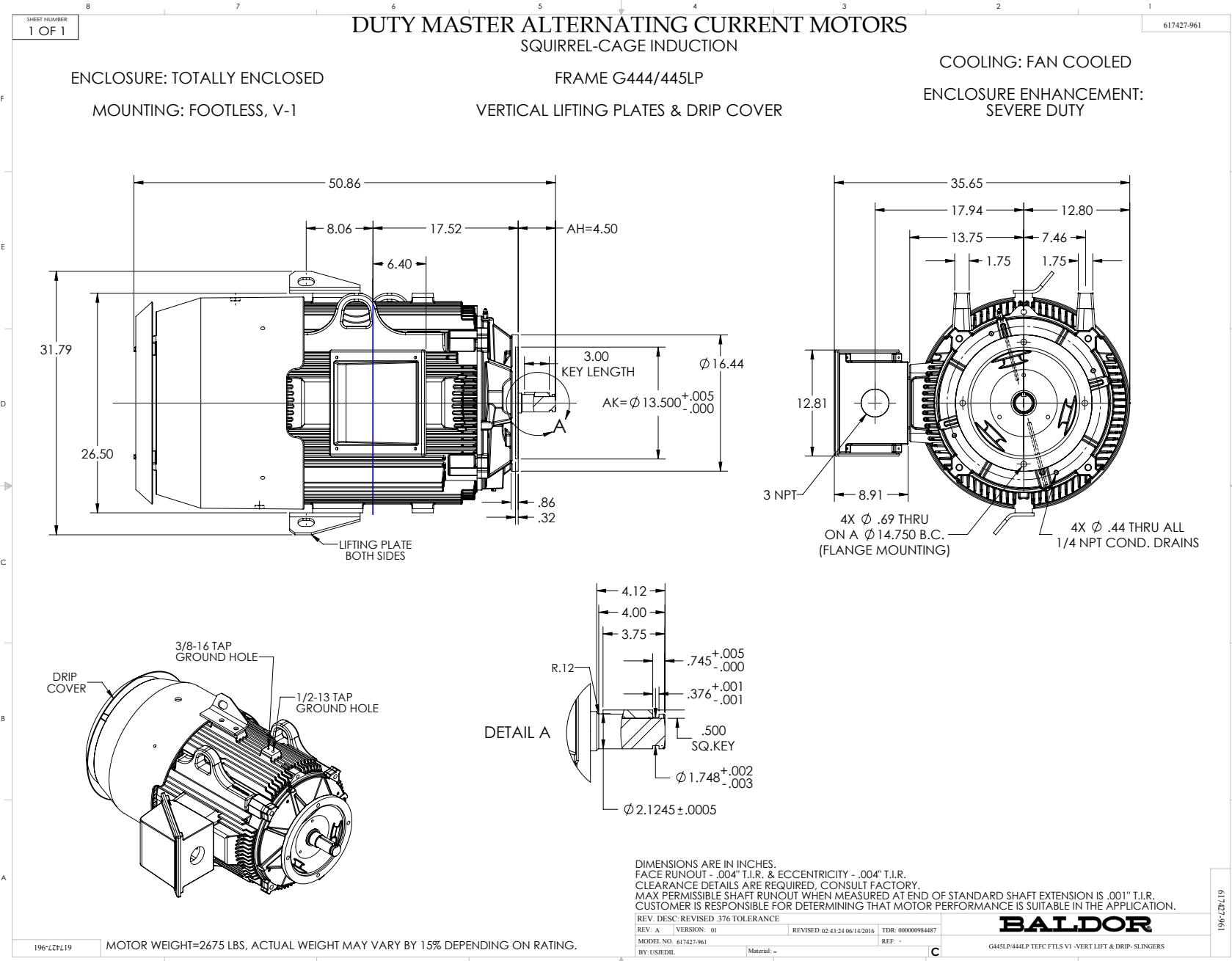



FLENDER ZAHNRADGETRIEBE

**Belüfterantriebe
Aerator Drives
Entraînements d'aérateurs**

FLENDER



GEAR REDUCER SUBMITTAL DATA

The Flender gear reducer(s) proposed for this project will be as shown on the detailed dimensional drawings and will have the characteristics shown on the data sheets enclosed with this package. Additionally, the units will have the following features of construction:

Helical gear type, AGMA Service factor as shown.

Classification III Sized in accordance with applicable AGMA standards 2001-C95.

Rated for 24 hours a day continuous running under moderate shock loads with 94% minimum efficiency.

Housing from rugged GG-25 cast iron construction with provisions for the attachment of suitable lifting devices.

Housing is stressed relieved, tested to preclude casting porosity and includes inspection cover(s) or inspection port(s).

Shafts supported on tapered, cylindrical or double roller bearings.

Gears and pinions made of alloy steel – 18CrNiMo7-6.

Dykem blue contact pattern inspection performed.

Shafting of medium carbon steel.

The gear teeth are carburized hardened and ground with sufficient hardness to obtain case and core properties meeting the requirements for grade 2 material in accordance with ANSI/AGMA 2001-C95.

The steel alloy shall be selected, and the heat treatment shall be controlled, to obtain a microstructure that meets all the requirements for grade 2 material in accordance with ANSI/AGMA 2001-C95.

All gears meet the accuracy requirements for AGMA quality no. Q12 in accordance with ANSI/AGMA 2001-B88.

Pitting resistance and bending fatigue resistance shall be rated in accordance with ANSI/AGMA 2001-C95.

All input bearings have a rating-life expectancy (B_{10}) of 100,000 hours.

The output shaft bearings have a rating-life expectancy (B_{10}) of 250,000 hours.

Bearing life is rated in accordance with ANSI/AFBMA Std. 11-1990 based on operating continuously at the rated full load horsepower and speed.

The lubrication of the speed reducer conforms to AGMA 9005-E02.

Lubrication system with pressure or level switch device, dipstick and oil fill and drain lines.

All grease lubricated bearings have seals to retain grease.

Low-speed shaft with grease lubricated bearing and dry well.

Grease lubrication pressure lines fed from fittings accessibly located above the platform.

Gear reducer assembly is factory tested under no load conditions. Inspections of running behavior for oil temperature sound pressure level, leak proof and gear ratio.

Coupling halves for reducer/motor shall be factory mounted and aligned, with motor and motor flange match marked.

Shop priming and finish painting with a high quality Polyurethane finish coating.

Belüfterantriebe

Aerator Drives

Entraînements d'aérateurs

Bauartenübersicht

Summary of Basic Types

Représentation des types

Stirradgetriebe

Helical gear units

Réducteur à engrenages
cylindriques

Bauart H2BV, 2-stufig
Größen 5 ... 16

Type H2BV, 2-stage
Sizes 5 ... 16

Type H2BV, 2 étages
Tailles 5 ... 16

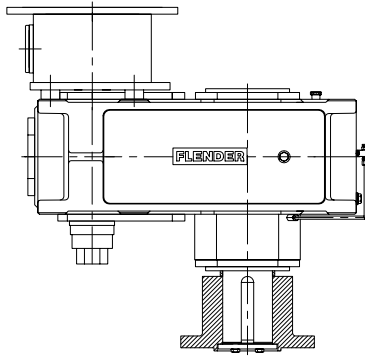

Stirradgetriebe

Helical gear units

Réducteur à engrenages
cylindriques

Bauart H3BV, 3-stufig
Größen 5 ... 16

Type H3BV, 3-stage
Sizes 5 ... 16

Type H3BV, 3 étages
Tailles 5 ... 16

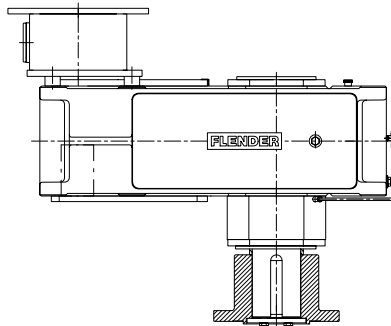

Kegelstirradgetriebe

Bevel-helical gear units

Réducteur à engrenages
cylindro-coniques

Bauart B3BV, 3-stufig
Größen 5 ... 16

Type B3BV, 3-stage
Sizes 5 ... 16

Type B3BV, 3 étages
Tailles 5 ... 16

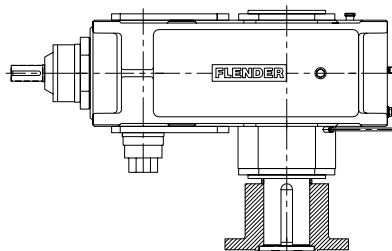

Stirradgetriebe

Helical Gear Units

Réducteur à engrenages
cylindriques

Dreistufig, Vertikal

Three Stage, Vertical

à trois trains, Vertical

Bauart H3BV

Type H3BV

Type H3BV

Größen 5 ... 16

Sizes 5 ... 16

Tailles 5 ... 16

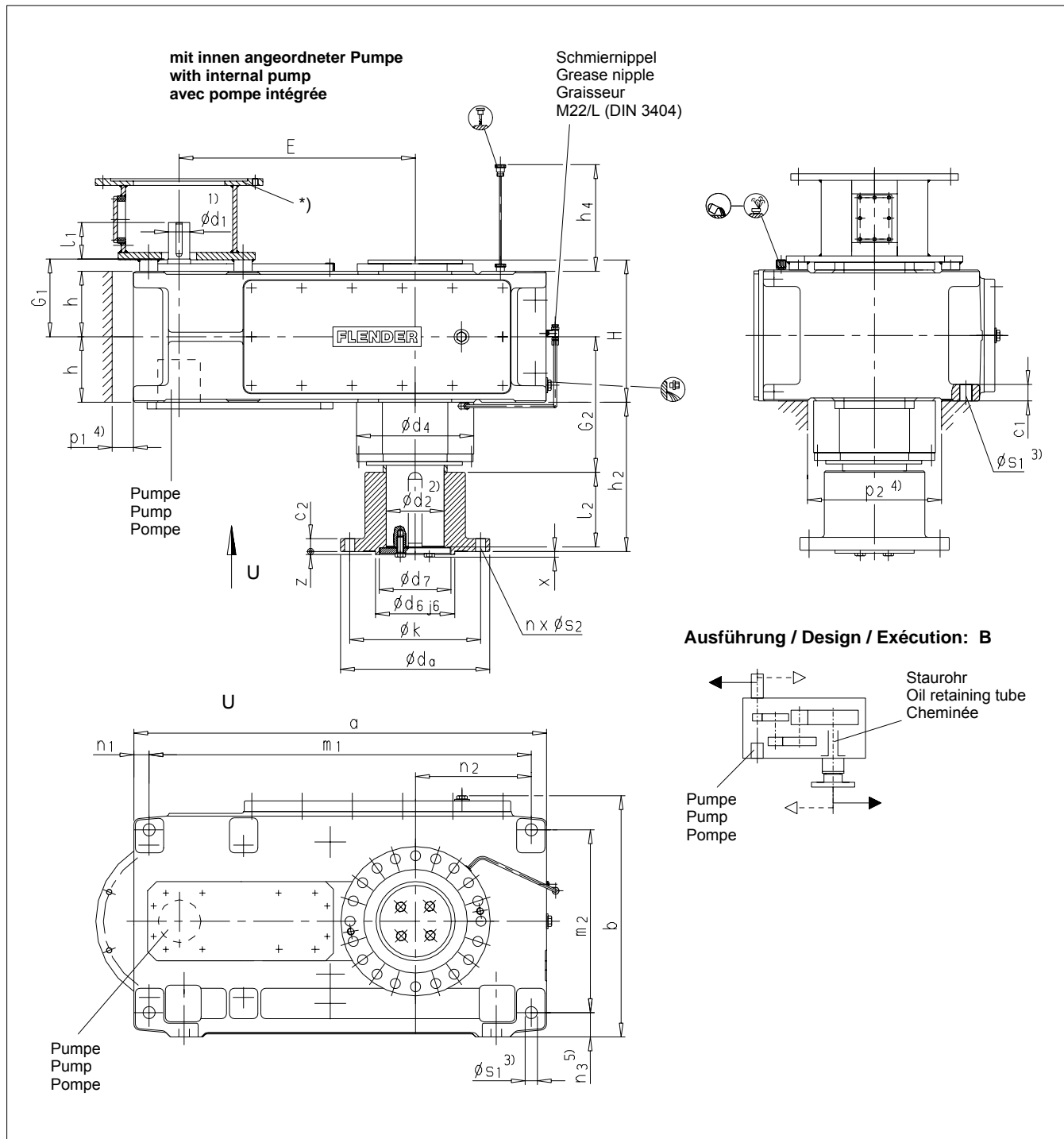

Ausführung / Design / Exécution: B

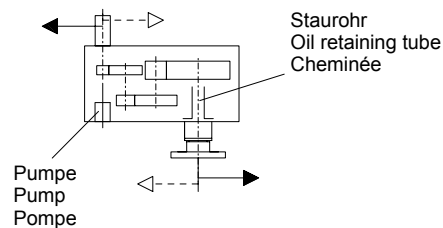

*) Motorlaterne und BIPEX-Kupplung
BWN siehe Seiten 35 - 36

*) For motor bell housing and BIPEX coupling
BWN, see pages 35 - 36

*) Lanterne moteur et accouplement
BIPEX BWN voir pages 35 - 36

1) $k_6 \leq \varnothing 24$ $m_6 \geq \varnothing 28$

1) $k_6 \leq \varnothing 24$ $m_6 \geq \varnothing 28$

1) $k_6 \leq \varnothing 24$ $m_6 \geq \varnothing 28$

2) **Größen 5 - 10:**

2) **Sizes 5 - 10:**

2) **Tailles 5 - 10:**

Passung: H_6 / n_6 , 1 Paßfeder

Fit: H_6 / n_6 , 1 parallel key

Ajuste: H_6 / n_6 , 1 clavette

Größen 11 - 12: Passung: H_6 / n_6

Sizes 11 - 12: Fit: H_6 / n_6

Tailles 11 - 12: Ajuste: H_6 / n_6

2 Paßfedern um 180° versetzt

2 parallel keys offset at 180°

2 clavettes décalées de 180°

Größen 13 - 16: Passung: H_7 / n_6

Sizes 13 - 16: Fit: H_7 / n_6

Tailles 13 - 16: Ajuste: H_7 / n_6

2 Paßfedern um 180° versetzt
Paßfeder DIN 6885/1 Form B und Zen-
trierung siehe Seite 30

2 parallel keys offset at 180°
For parallel key DIN 6885/1 form B and
for centre hole, see page 30

2 clavettes décalées de 180°
Clavette DIN 6885/1 forme B et centrage
voir page 30

3) Fußschrauben mit Mindest-Festigkeits-
klasse 8.8

3) Foundation bolts of min. property class
8.8

3) Vis de fixations en classe 8.8

4) Freiraum für Röhre und Deckel, genaue
Maße ggf. anfragen

4) Space for pipes and cover. For exact
dimensions, please refer to us

4) Espace libre pour passage tuyauterie et
couvercle, cotes précises sur demande

Stirnradgetriebe

Helical Gear Units

Réducteur à engrenages
cylindriques

Dreistufig, Vertikal

Three Stage, Vertical

à trois trains, Vertical

Bauart H3BV

Type H3BV

Type H3BV

Größen 5 ... 16

Sizes 5 ... 16

Tailles 5 ... 16

Größe Size Taille	Maße in mm / Dimensions in mm / Dimensions en mm																						
	Antrieb / Input / Entrée																						
	i _N 22.4 - 45		i _N 25 - 45		i _N 25 - 50		i _N 28 - 56		i _N 31.5 - 56		i _N 50 - 63		i _N 56 - 71		i _N 63 - 80		i _N 71 - 90		i _N 80 - 100		i _N 90 - 112		G ₁
d ₁ ¹⁾	l ₁	d ₁ ¹⁾	l ₁	d ₁ ¹⁾	l ₁	d ₁ ¹⁾	l ₁	d ₁ ¹⁾	l ₁	d ₁ ¹⁾	l ₁	d ₁ ¹⁾	l ₁	d ₁ ¹⁾	l ₁	d ₁ ¹⁾	l ₁	d ₁ ¹⁾	l ₁	d ₁ ¹⁾	l ₁		
5			40	70						30	50					24	40						160
6									40	70					30	50					24	40	160
7			45	80						35	60					28	50						185
8									45	80					35	60					28	50	185
9			60	125						45	100					32	80						230
10									60	125					45	100					32	80	230
11			70	120						50	80					42	70						255
12									70	120					50	80					42	70	255
13	85	160								60	135					50	110						310
14						85	160							60	135						50	110	310
15	100	200								75	140					60	140						350
16					100	200							75	140					60	140			350

Größe Size Taille	Maße in mm / Dimensions in mm / Dimensions en mm																
	Zahnradgetriebe / Gear units / Réducteurs à engrenages																
	a	b	c ₁	d ₄	E	h	h ₄	H	m ₁	m ₂	n ₁	n ₂	n ₃ ⁵⁾	p ₁ ⁴⁾	p ₂ ⁴⁾	s ₁	
5	690	482	30	275	405	127.5	225	310	630	360	30	175	50	35	270	24	
6	770	482	30	280	440	127.5	225	310	710	360	30	220	50	35	270	24	
7	845	572	36	340	495	150	275	360	775	430	35	215	65	35	330	28	
8	950	582	36	350	540	150	275	360	880	430	35	275	65	35	330	28	
9	1000	662	45	365	580	185	315	440	920	490	40	260	75	40	370	36	
10	1100	662	45	410	630	185	315	440	1020	490	40	310	75	40	370	36	
11	1200	782	54	435	705	215	350	510	1100	600	50	295	80	50	440	40	
12	1355	790	54	455	775	215	350	510	1255	600	50	380	80	50	440	40	
13	1395	920	61	495	820	272.5	250	625	1300	680	50	360	-	50	500	48	
14	1535	920	61	520	890	272.5	250	625	1440	680	50	430	-	50	500	48	
15	1680	980	72	590	987	310	275	700	1565	750	60	430	-	50	570	55	
16	1770	980	72	610	1033	310	275	700	1655	750	60	475	-	50	570	55	

Größe Size Taille	Maße in mm / Dimensions in mm / Dimensions en mm				Öl Oil Huile (l)	Gewicht Weight Poids (kg)	Maße in mm / Dimensions in mm / Dimensions en mm									Gewicht Weight Poids (kg)
	Abtrieb / Output / Sortie						Kupplungsflansch / Coupling flange / Flasque d'accouplement									
	d ₂ ²⁾	G ₂	h ₂	l ₂			c ₂	d _a	d ₆	d ₇	k	n x Ø s ₂	x	z		
5	105	272.5	300	145	14	350	25	290	150	135	250	12 x 22	12	7	28	
6	115	272.5	300	145	15	405	25	290	150	135	250	16 x 22	12	7	25	
7	125	305	350	180	25	600	30	360	180	160	310	12 x 26	14	8	28	
8	135	305	350	180	30	705	30	360	180	160	310	16 x 26	14	8	28	
9	145	385	430	215	40	970	38	400	215	195	350	18 x 26	16	10	85	
10	160	385	430	215	45	1140	38	430	215	195	380	20 x 26	16	10	103	
11	170	445	490	245	66	1565	42	470	260	235	410	16 x 33	20	10	134	
12	190	445	490	245	75	1845	42	490	260	235	430	20 x 33	20	10	144	
13	200	522.5	590	310	85	2465	50	500	260	230	430	18 x 33	6	6	190	
14	220	522.5	630	350	105	2840	50	520	300	260	450	20 x 33	6	6	222	
15	240	605	735	400	130	3735	60	580	320	280	500	18 x 39	6	6	326	
16	260	605	735	400	160	4160	60	600	350	305	520	20 x 39	6	6	344	

5) Größen 13 ... 16 ohne seitliche Fußleisten
 5) Sizes 13 ... 16 without lateral bearing surfaces
 5) Tailles 13 ... 16 sans pied sur les cotés

FLENDER

CORPORATION

150 Tollgate Road
Elgin, Illinois 60123
Phone: (312) 831-1890

GENERAL INFORMATION

3701946

DATE: APRIL, 87

Prior to shipment all gear units are thoroughly inspected and test run. During the period covered by the Flender warranty, the gear boxes may be opened only upon prior written consent to maintain the warranty.

Units may only be operated at the horsepower, speed, and ratio shown on the nameplate. Before changing any of these, submit complete nameplate data and new application conditions to the factory for approval.

Speed reducers are generally shipped unboxed. Accessories such as pressure gauge, thermometer, oil circulation indicator, etc., are already assembled. Only upon special request will auxiliary equipment be packed separately.

Shaft projections and hollow shaft bores are coated with a rust preventative which is resistant to sea water and tropical conditions for a period of three months from the date of shipment. It is to be removed with mineral solvent. **NEVER USE ABRASIVE PAPER!**

The inner parts of the reducers are treated for normal transportation conditions, including overseas shipment. This treatment is adequate for up to three months from the date of shipment.



FLENDER CORPORATION

950 Tollgate Road
Elgin, Illinois 60123
Phone: (708) 931-1990

PRESSURE SWITCH LOW PRESSURE CONTROL

3701956

DATE: SEPT, 90

Pressure lubricated gear units are fitted with an oil pressure switch, which activates whenever the oil pressure drops below 7 PSI.

APPLICATION

- A. The switch can be hooked up to a warning system in order to give a signal whenever the oil pressure drops below 7 PSI.
- B. The switch can be integrated into the wiring system of the prime mover in order to shut off the power whenever the oil pressure drops below 7 PSI. In this case, a relay has to be used.

For a start up of gear units with direct shaft driven flange pumps a time relay has to be used.

SPECIFICATIONS

Type and Make	: Ashcroft B420B (or Equivalent)
EL Rating	: 15A, 125/250 VAC
Diaphragm	: Viton
Enclosure	: NEMA 4
Conduit Connection	: 3/4" NPT
Proof	: 1000 PSI
Range	: 30 PSI
Wiring	: NO —•— NC



ADJUSTMENT OF SET POINT

A single setpoint adjustment nut (7/8") is located at the bottom of the inside of the enclosure.

For an accurate setting, a calibration stand with a pressure gauge must be used.

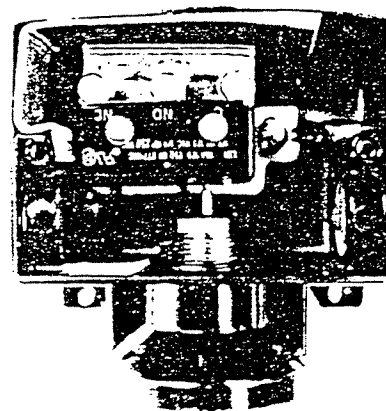
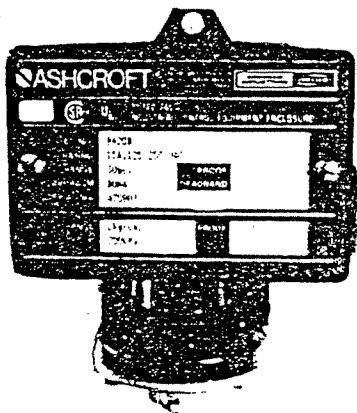

High pressure control see bulletin 3701955

These operating instructions are binding for breathers according to FLENDER works standard W 5122.

Mounting

The thread of the filter has to be coated with sealing compound LOCTITE 572 before screwing it into the female thread.

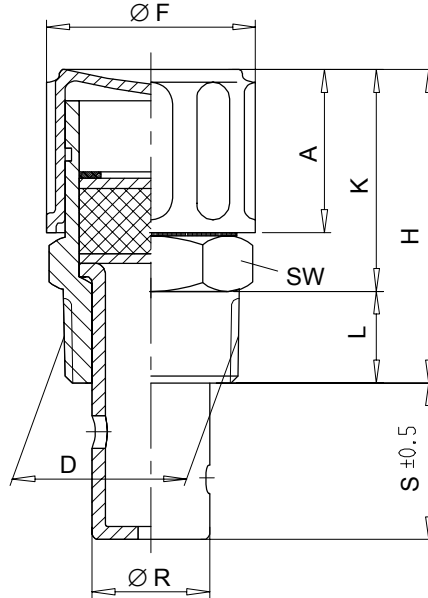

D	SW	L	K	H	A	F	R	S
R 1/4	22	8	23	35	19	28	8	16.5
R 1/2	22	12	26	38	19	28	10	17
R 3/4	27	14	32	46	25	32	18	23

Material: Stainless steel
 Tubes made out of oil-resistant plastics

Temperature resistance: up to 120 °C

Design: Tapered thread acc. to DIN 2999 (Taper 1 : 16)

Diese technische Unterlage hat gesetzlichen Schutz (DIN 34)

FLENDER

CORPORATION

950 Tollgate Road
Elgin, Illinois 60123
Phone: (708) 931-1990

LONG-TERM STORAGE

3701894

TYPE: ALL

DATE: SEPT, 90

GENERAL

Long-term storage preparation is required whenever a reducer is inactive for three (3) months or more after shipment from the factory.

PROCEDURE FOR LONG-TERM STORAGE

1. Remove the breather(s) and replace with a plug. Store the breather for later use.
2. Spray the inside of the unit with SHELL ENSIS fluid SDC, making sure to thoroughly coat all surfaces. Spray the fluid especially into the housing oil pockets. Also, rotate the gears (shafts) by hand to assure complete coverage.
3. Coat all unpainted, exterior surfaces with cosmoline.
4. Tape all shaft/seal areas with a pressure sensitive tape such as duct tape. Do not use masking or banding tapes.
5. Repeat step 2 above every six (6) months and steps 3 and 4, as required.
6. As an alternate to spraying the inside of the unit with Ensis fluid, fill the unit completely with the recommended oil indicated on service manual sheet 3701947 and rotate by hand once every month. Grease the seal area. Check the seals for leakage and the seal areas for any signs of corrosion. Seals may have to be replaced at start up.
7. Reducer should be stored in a dry, covered storage area away from vibrating equipment.
8. CAUTION: The customer is responsible for complying with all required safety precautions and federal, state and local regulations when using the referenced products.

PROCEDURE FOR START UP AFTER LONG-TERM STORAGE

1. Ensis fluid needs to be drained but not necessarily flushed before start up. It is compatible with all recommended lubricants listed in service sheet 3701947.
2. Remove all tape.
3. Replace the air breather(s).
4. Clean off all cosmoline, unpainted surfaces with Safety-Kleen Solvent-140 or equal mineral solvent. NEVER USE ABRASIVES.
5. CAUTION: The customer is responsible for complying with all required safety precautions and federal, state and local regulations when using the referenced products.
6. Refer to service manual sheets 3701964 and 3701954 for installation and start up instructions.

FOR REDUCERS STORED MORE THAN 3 YEARS
AFTER DATE OF SHIPMENT
PLEASE CONTACT FLENDER CORPORATION



Multi-turn actuators

SA 07.2 – SA 16.2

SAR 07.2 – SAR 16.2

Control unit: electronic (MWG)
with actuator controls

AUMATIC AC 01.2 Non-Intrusive

Control

→ Parallel

Profibus DP

Modbus

Foundation Fieldbus



12. Technical data

Information The following technical data includes standard and optional features. For detailed information on the customer-specific version, refer to the order-relevant data sheet. This data sheet can be downloaded from the Internet at <http://www.auma.com> in German and English (indication of commission number required).

12.1. Features and functions of actuator

Type of duty ¹⁾	Standard: <ul style="list-style-type: none"> • SA: Short-time duty S2 - 15 min • SAR: Intermittent duty S4 - 25 % Options: <ul style="list-style-type: none"> • SA: Short-time duty S2 - 30 min • SAR: Intermittent duty S4 - 50 % • SAR: Intermittent duty S5 – 25 %
Torque range	Refer to actuator name plate
Output speed	Refer to actuator name plate
Motor	Standard: 3-ph AC asynchronous motor, type IM B9 according to IEC 60034
Motor voltage and frequency	Refer to motor name plate
Insulation class	Standard: F, tropicalized Option: H, tropicalized
Motor protection	Standard: Thermostiches (NC) Option: PTC thermistors (according to DIN 44082)
Self-locking	Self-locking: Output speeds up to 90 rpm (50 Hz), 108 rpm (60 Hz) NOT self-locking: Output speeds up to 125 rpm (50 Hz), 150 rpm (60 Hz) Multi-turn actuators are self-locking, if the valve position cannot be changed from standstill while torque acts upon the output drive.
Limit switching	Magnetic limit and torque transmitter MWG for 1 to 500 turns per stroke or 10 to 5,000 turns per stroke
Torque switching	Via MWG (like limit switching)
Position feedback signal, analogue (option)	Via MWG
Torque feedback signal, analogue (option)	Via MWG
Mechanical position indicator (option)	Continuous indication, adjustable indicator disc with symbols OPEN and CLOSED
Heater in switch compartment	Standard: Resistance type heater, 5 W, 24 V AC, (internal supply)
Motor heater (option)	Voltages: 110 – 120 V AC, 220 – 240 V AC or 400 V AC (externally supplied) Power depending on the size 12.5 – 25 W
Manual operation	Manual drive for setting and emergency operation, handwheel does not rotate during electrical operation. Option: Handwheel lockable
Connection to controls	AUMA plug/socket connector with screw-type connection
Valve attachment	Standard: B1 according to EN ISO 5210 Options: A, B2, B3, B4 according to EN ISO 5210 A, B, D, E according to DIN 3210 C according to DIN 3338 Special output drive types: AF, B3D, ED, DD, IB1, IB3 A prepared for stem lubrication
Sensor system	
Indication for manual operation (option)	Indication whether manual operation is active/not active via switch (1 change-over contact)
Temperature for motor (option)	Temperature sensor PT 100
Temperature for gear housing (option)	Temperature sensor PT 100

- 1) For nominal voltage and 40 °C ambient temperature and an average load with running torque or modulating torque according to separate technical data. The type of duty must not be exceeded.

Technical data for handwheel activation switches	
Mechanical lifetime	10 ⁶ starts
Silver plated contacts:	
U min.	12 V DC
U max.	250 V AC
I max. AC current	3 A at 250 V (inductive load, cos phi = 0.8)
I max. DC current	3 A at 12 V (resistive load)

12.2. Features and functions of actuator controls

Power supply Mains frequency	For mains voltage and mains frequency, refer to name plates at the controls and the motor Permissible variation of the mains voltage: ±10 % Permissible variation of the mains frequency: ±5 % Option: Permissible variation of the mains voltage: ±30 %
External supply of the electronics (option)	24 V DC +20 % / -15 % Current consumption: Basic version approx. 250 mA, with options up to 500 mA The external power supply must have a reinforced insulation against the mains voltage in accordance with IEC 61010-1 and may only be supplied by a circuit limited to 150 VA in accordance with IEC 61010-1.
Current consumption	Current consumption of the controls depending on the mains voltage: For permissible variation of mains voltage by ±10 %: <ul style="list-style-type: none"> • 100 to 120 V AC = max. 740 mA • 208 to 240 V AC = max. 400 mA • 380 to 500 V AC = max. 250 mA • 515 to 690 V AC = max. 200 mA For permissible variation of mains voltage by ±30 %: <ul style="list-style-type: none"> • 100 to 120 V AC = max. 1,200 mA • 208 to 240 V AC = max. 750 mA • 380 to 500 V AC = max. 400 mA • 515 to 690 V AC = max. 400 mA Motor current consumption: Refer to motor name plate
Overvoltage category	Category III according to IEC 60364-4-443
Rated power	The controls are designed for the rated motor power, refer to motor name plate
Switchgear ^{1) 2)}	Standard: Reversing contactors (mechanically and electrically interlocked) for motor power up to power class A1 Options: <ul style="list-style-type: none"> • Reversing contactors (mechanically and electrically interlocked) for motor power up to power class A2 • Thyristor unit for mains voltage up to 500 V AC (recommended for modulating actuators) for AUMA power classes B1, B2 and B3
Control	Standard: Via digital inputs OPEN, STOP, CLOSE, EMERGENCY (via opto-isolator, OPEN, STOP, CLOSE with one common), respect minimum pulse duration for modulating actuators Option: Additional enable inputs for directions OPEN and CLOSE
Voltage and current values for control inputs ³⁾	Standard: 24 V DC, current consumption: approx. 10 mA per input Options: 48 V DC, current consumption: approx. 7 mA per input 60 V DC, current consumption: approx. 9 mA per input 110 V DC, current consumption: approx. 8 mA per input 115 V DC, current consumption: approx. 15 mA per input 115 V AC, current consumption: approx. 15 mA per input

Status signals	<p>Standard: 6 programmable output contacts:</p> <ul style="list-style-type: none"> • 5 potential-free NO contacts with one common, max. 250 V AC, 1 A (resistive load) <ul style="list-style-type: none"> - Default configuration: End position CLOSED, end position OPEN, selector switch in REMOTE, torque fault CLOSE, torque fault OPEN • 1 potential-free change-over contact, max. 250 V AC, 5 A (resistive load) <ul style="list-style-type: none"> - Default configuration: Collective fault signal (torque fault, phase failure, motor protection tripped) <p>Options: 6 programmable output contacts:</p> <ul style="list-style-type: none"> • 5 change-over contacts with one common, max. 250 V AC, 5 A (resistive load) • 1 potential-free change-over contact, max. 250 V AC, 5 A (resistive load) <p>12 programmable output contacts:⁴⁾</p> <ul style="list-style-type: none"> • 10 potential-free NO contacts, one common for respectively 5 contacts, max. 250 V AC, 1 A (resistive load) • 2 potential-free change-over contacts, max. 250 V AC, 5 A (resistive load) <p>6 programmable output contacts:</p> <ul style="list-style-type: none"> • 6 potential-free change-over contacts without one common, per contact max. 250 V AC, 5 A (resistive load) <p>10 programmable output contacts:⁴⁾</p> <ul style="list-style-type: none"> • 10 potential-free change-over contacts without one common, per contact max. 250 V AC, 5 A (resistive load) <p>All output signals must be supplied with the same potential.</p>
Position feedback signal	Galvanically isolated analogue output E2 = 0/4 – 20 mA (load max. 500 Ω)
Voltage output	<p>Standard: Auxiliary voltage 24 V DC, max. 100 mA for supply of the control inputs, galvanically isolated from internal voltage supply</p> <p>Option: Auxiliary voltage 115 V AC, max. 30 mA to supply the control inputs⁵⁾, galvanically isolated from internal voltage supply</p>
Local controls	<p>Standard:</p> <ul style="list-style-type: none"> • Selector switch LOCAL - OFF - REMOTE (lockable in all three positions) • Push buttons OPEN, STOP, CLOSE, RESET • 6 indication lights: <ul style="list-style-type: none"> - End position CLOSED (yellow), torque fault CLOSE (red), motor protection tripped (red), torque fault OPEN (red), end position and running indication OPEN (green), Bluetooth (blue) • Graphic LC display, illuminated <p>Options:</p> <ul style="list-style-type: none"> • Special colours for the 5 indication lights: <ul style="list-style-type: none"> - End position CLOSED (green), torque fault CLOSE (blue), torque fault OPEN (yellow), motor protection tripped (white), end position OPEN (red)
Bluetooth Communication interface	<p>Bluetooth class II chip, version 2.0 with a range up to 10 m in industrial environments. Supports the SPP Bluetooth profile (Serial Port Profile).</p> <p>Programming software: AUMA CDT, commissioning and diagnostic tool for windows based PCs, PDAs and smart phones</p>

<p>Application functions</p>	<p>Standard:</p> <ul style="list-style-type: none"> • Switch-off mode adjustable <ul style="list-style-type: none"> - Limit or torque seating for end position OPEN and end position CLOSED • Torque by-pass, adjustable up to 5 seconds (no torque monitoring during this time) • Start and end of stepping mode as well as ON and OFF time (1 up to 1,800 seconds) can be programmed individually for directions OPEN and CLOSE. • Any 8 intermediate positions between 0 and 100 %, reaction and signal behaviour programmable <p>Options:</p> <ul style="list-style-type: none"> • Positioner <ul style="list-style-type: none"> - Position setpoint via analogue input E1 = 0/4 – 20 mA - Automatic adaptation of the dead band (adaptive behaviour can be selected) - Split Range operation - MODE input for selecting between OPEN - CLOSE duty and modulating duty
<p>Failure functions</p>	<p>Standard:</p> <ul style="list-style-type: none"> • EMERGENCY operation, behaviour programmable <ul style="list-style-type: none"> - Digital input low active, reaction can be selected: Stop, move to end position CLOSED, move to end position OPEN, move to intermediate position - Torque monitoring can be by-passed during EMERGENCY operation. - Thermal protection can be by-passed during EMERGENCY operation (only in combination with thermoswitch in the actuator, not with PTC thermistor). <p>Options:</p> <ul style="list-style-type: none"> • Enabling local controls via digital input Enable LOCAL. Thus, the actuator operation can be enabled or disabled via push buttons on the local controls. • Local Stop <ul style="list-style-type: none"> - The actuator can be stopped via push button Stop of local controls if the selector switch is in position REMOTE. Not activated when leaving the factory. • EMERGENCY stop button (latching) interrupts electrical operation irrespective of the selector switch position. • Interlock, enabling the operation commands OPEN or CLOSE via digital inputs Interlock OPEN or Interlock CLOSE
<p>Monitoring functions</p>	<p>Standard:</p> <ul style="list-style-type: none"> • Valve overload protection (adjustable), results in switching off and generates fault indication • Motor temperature monitoring (thermal monitoring), results in switching off and generates fault indication • Monitoring the heater within the actuator, generates warning signal • Monitoring of permissible on-time and number of starts (adjustable), generates warning signal • Operation time monitoring (adjustable), generates warning signal • Phase failure monitoring, results in switching off and generates fault indication • Automatic correction of the direction of rotation upon wrong phase sequence (3-phase AC current)

Diagnostic functions	<ul style="list-style-type: none"> • Electronic device ID with order and product data • Logging of operating data: A resettable counter and a lifetime counter each for: <ul style="list-style-type: none"> - Motor running time, number of starts, torque switch trippings in end positions CLOSED, limit switch trippings in end position CLOSED, torque switch trippings in end position OPEN, limit switch trippings in end position OPEN, torque faults CLOSE, torque faults OPEN, motor protection trippings • Time-stamped event report with setting, operation and fault history: <ul style="list-style-type: none"> - Status signals in compliance with NAMUR recommendation NE 107: "Failure", "Function check", "Out of specification", "Maintenance required" • Torque characteristics <ul style="list-style-type: none"> - 3 torque characteristics (torque-travel characteristic) for opening and closing directions, can be saved separately. Torque characteristics stored can be shown on the display.
Electrical connection	<p>Standard: AUMA plug/socket connector (S) with screw-type connection and M-threads</p> <p>Options:</p> <ul style="list-style-type: none"> • Pg-threads, NPT-threads, G-threads, special threads • Gold-plated control contacts (pins and sockets) • Parking frame for wall mounting of the disconnected plug • Protection cover for plug compartment (when plug is removed)
Wiring diagram	Refer to name plate

- 1) The reversing contactors are designed for a lifetime of 2 million starts.
- 2) For the assignment of AUMA power classes, please refer to electrical data on actuator.
- 3) All input signals must be supplied with the same potential.
- 4) Not possible for low temperature versions with heating system
- 5) Not possible in combination with PTC tripping device

Further options for Non-intrusive version with MWG in the actuator	
Setting limit and torque switching via the controls' local controls	
Torque feedback signal	Galvanically isolated analogue output E6 = 0/4 – 20 mA (max. load 500 Ω), only possible in combination with output contacts

12.3. Service conditions

Use	Indoor and outdoor use permissible
Mounting position	Any position
Enclosure protection according to EN 60529	<p>Standard: IP68 with AUMA 3-ph AC motor/1-ph AC motor</p> <p>According to AUMA definition, enclosure protection IP68 meets the following requirements:</p> <ul style="list-style-type: none"> • Depth of water: maximum 8 m head of water • Duration of continuous immersion in water: max. 96 hours • Up to 10 operations during flooding. • Modulating duty is not possible during continuous immersion. <p>For actual version, refer to actuator/controls name plate.</p>
Corrosion protection	<p>Standard:</p> <ul style="list-style-type: none"> • KS: Suitable for installation in industrial units, in water or power plants with a low pollutant concentration as well as for installation in occasionally or permanently aggressive atmosphere with a moderate pollutant concentration (e.g. in wastewater treatment plants, chemical industry) <p>Options:</p> <ul style="list-style-type: none"> • KX: Suitable for installation in extremely aggressive atmospheres with high humidity and high pollutant concentration
Installation altitude	<p>Standard: ≤ 2,000 m above sea level</p> <p>Option: > 2,000 m above sea level, please contact AUMA</p>
Humidity	Up to 100 % relative humidity over the entire permissible temperature range
Pollution degree	Pollution degree 4 (when closed) according to EN 50178
Finish coating	Standard: Paint based on polyurethane (powder coating)
Colour	Standard: AUMA silver-grey (similar to RAL 7037)

Ambient temperature	Standard: <ul style="list-style-type: none"> • Open-close duty: –25 °C to +70 °C • Modulating duty: –25 °C to +60 °C For actual version, refer to actuator/controls name plate.
Vibration resistance according to IEC 60068-2-6	1 g, from 10 to 200 Hz Resistant to vibration during start-up or for failures of the plant. However, a fatigue strength may not be derived from this. Not valid in combination with gearboxes.
Lifetime	AUMA multi-turn actuators meet or exceed the lifetime requirements of EN 15714-2. For further details, please contact AUMA
Weight	Refer to separate technical data

12.4. Accessories

Wall bracket ¹⁾	AUMATIC mounted separately from the actuator, including plug/socket connector. Connecting cables on request. Recommended for high ambient temperatures, difficult access, or in case of heavy vibration during service
Programming software for PC	AUMA CDT

1) Cable distance between actuator and AUMATIC max. 100 m. Requires separate data cable for MWG. If actuator and AUMATIC are separated at a later date, the max. cable length is 10 m.

12.5. Further information

EU Directives	<ul style="list-style-type: none"> • Electromagnetic Compatibility (EMC): (2004/108/EC) • Low Voltage Directive: (2006/95/EC) • Machinery Directive: (2006/42/EC)
---------------	--

14. Certificates**14.1. Declaration of Incorporation and EC Declaration of Conformity**

AUMA Riester GmbH & Co. KG Tel +49 7631 809-0
 Aumastr. 1 Fax +49 7631 809-1250
 79379 Müllheim, Germany Riester@auma.com
 www.auma.com



**Original Declaration of Incorporation of Partly Completed Machinery
 (EC Directive 2006/42/EC) and EC Declaration of Conformity in compliance with the
 Directives on EMC and Low Voltage**

for electric AUMA Actuators of the type ranges

Multi-turn actuators	SA 07.2 – SA 16.2 and SAR 07.2 – SAR 16.2
Part-turn actuators	SQ 05.2 – SQ 14.2 and SQR 05.2 – SQR 14.2

in versions **AUMA NORM, AUMA SEMIPACT, AUMA MATIC** or **AUMATIC**.

AUMA Riester GmbH & Co. KG as manufacturer declares herewith, that the above mentioned multi-turn and part-turn actuators meet the following basic requirements of the EC Machinery Directive 2006/42/EC: Annex I, articles 1.1.2, 1.1.3, 1.1.5, 1.2.1, 1.2.6, 1.3.1, 1.3.7, 1.5.1, 1.6.3, 1.7.1, 1.7.3, 1.7.4

The following harmonised standards within the meaning of the Machinery Directive have been applied:

EN ISO 12100: 2010 ISO 5211: 2001
 EN 5210: 1996

With regard to the partly completed machinery, the manufacturer commits to submitting the documents to the competent national authority via electronic transmission upon request. The relevant technical documentation pertaining to the machinery described in Annex VII, part B has been prepared.

AUMA multi-turn and part-turn actuators are designed to be installed on industrial valves. AUMA multi-turn and part-turn actuators must not be put into service until the final machinery into which they are to be incorporated has been declared in conformity with the provisions of the EC Directive 2006/42/EC.

Authorised person for documentation: Peter Malus, Aumastrasse 1, D-79379 Muellheim

As partly completed machinery, the multi-turn and part-turn actuators further comply with the requirements of the following directives and the respective approximation of national laws as well as the respective harmonised standards as listed below:

(1) Directive relating to Electromagnetic Compatibility (EMC) (2004/108/EC)

EN 61000-6-4: 2007 / A1: 2011
 EN 61000-6-2: 2005 / AC: 2005

(2) Low Voltage Directive (2006/95/EC)

EN 60204-1: 2006 / AC: 2010
 EN 60034-1: 2010 / AC: 2010
 EN 50178: 1997

Muellheim, 2013-12-01

H. Newerla, General Management

This declaration does not contain any guarantees. The safety instructions in product documentation supplied with the devices must be observed. Non-concerted modification of the devices voids this declaration.

Y006.332/003/en

auma[®]

Solutions for a world in motion

AUMA Riester GmbH & Co. KG

P.O.Box 1362

DE 79373 Muellheim

Tel +49 7631 809 - 0

Fax +49 7631 809 - 1250

riester@auma.com

www.auma.com



Y004.761/003/en/3.13

auma[®]

Part-turn gearboxes

Worm gearboxes
GS 50.3 – GS 250.3
for flange types FA

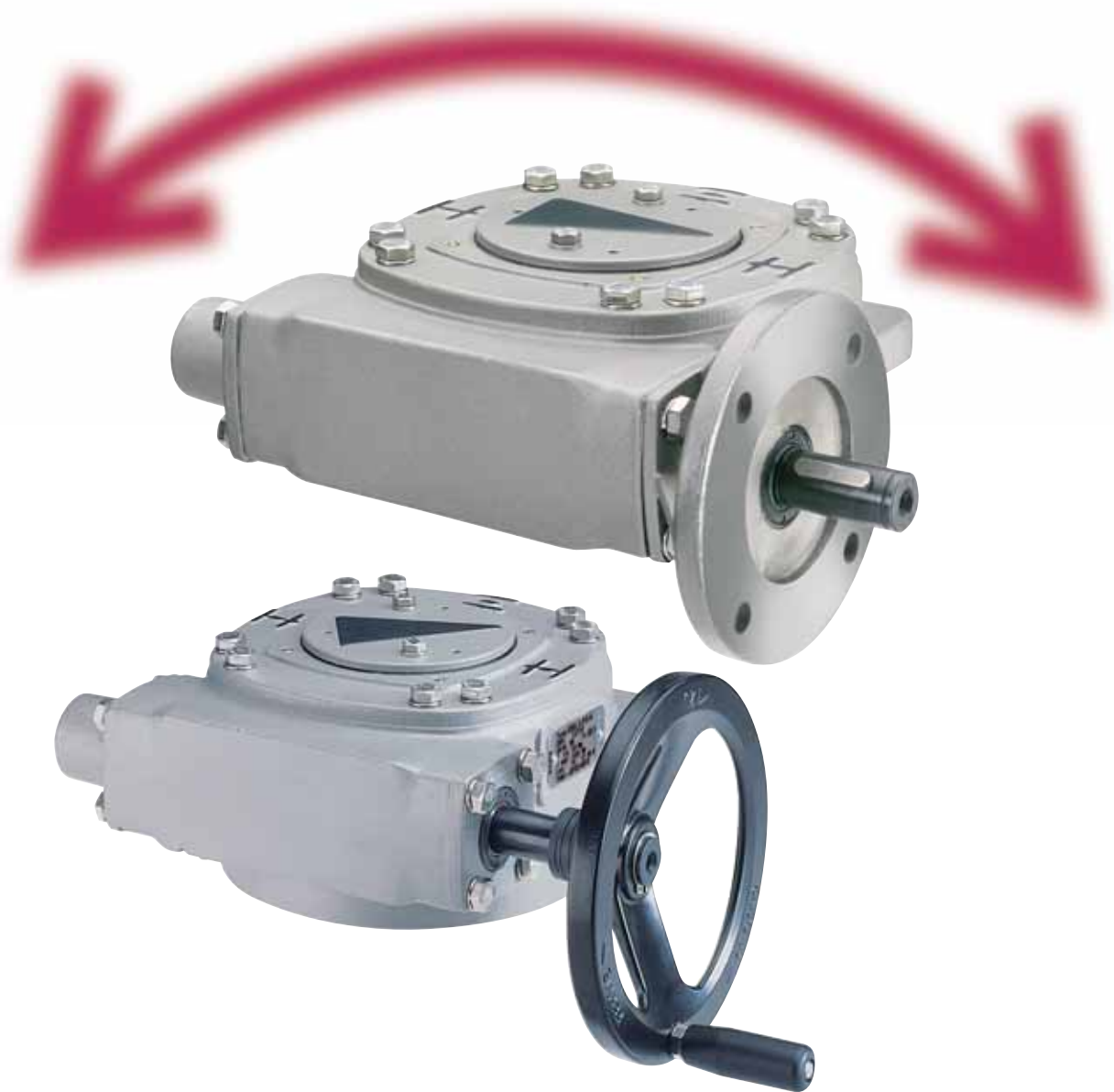

AUMA Actuators, Inc.
Registered to ISO 9001
Certificate No. A4682

Operation instructions

2. Technical data

Features and functions												
Version	Standard: clockwise rotation RR, counterclockwise rotation LL, option: RL or LR											
Housing material	Standard: cast iron (GJL-250), Option: spheroidal cast iron (GJS-400-15)											
Self-locking	The gearboxes are self-locking when at stand-still under normal service conditions; strong vibrations may cancel the self-locking effect. While in motion, safe breaking is not guaranteed. If this is required, a separate brake must be used.											
Output torques	Type	100 % max. ft lbs.		140 % max. ft lbs.		Output torques 175 % ¹⁾ max. ft lbs.			200 % ¹⁾ max. ft lbs.		Modulating torque ²⁾ max. ft lbs.	
	GS 50.3	184	258	–			369	92				
	GS 63.3	369	516	–			738	184				
	GS 80.3	738	1,033	–			1,475	369				
	GS 100.3	1,475	2,065	–			2,950	738				
	GS 125.3	2,950	4,130	–			5,900	1,475				
	GS 160.3	5,900	8,298	10,326	–			2,950				
	GS 200.3	11,801	16,595	20,652	–			5,900				
GS 250.3	23,602	32,822	41,303	–			16,000					
End stops	Positive for both end positions by traveling nut, sensitive adjustment											
Strength of end stop	Guaranteed strength of end stop (in ft lbs.) for input side operation											
	Type	GS 50.3	GS 63.3	GS 80.3	GS 100.3			GS 125.3				
	Reduction gearing	–	–	–	VZ 2.3	VZ 3.3	VZ 4.3	VZ 2.3	VZ 3.3	VZ 4.3		
	ft lbs.	185	330	330	370			185	370			
	Type	GS 160.3			GS 200.3			GS 250.3				
	Reduction gearing	GZ 160.3			GZ 200.3			GZ 250.3				
Reduction ratio	4:1	8:1	4:1	8:1	16:1	4:1	8:1	16:1				
ft lbs.	370	330	370			370						
Swing angle GS 50.3 – GS 125.3	Standard: Fixed swing angle up to max. 100°; set in the factory to 92° unless ordered otherwise. Options: Adjustable in steps of: 10° – 35°, 35° – 60°, 60° – 80°, 80° – 100°, 100° – 125°, 125° – 150°, 150° – 170°, 170° – 190° For version with worm wheel made of bronze: swing angle > 190°, Multi-turn version without end stops, version GSD ³⁾											
Swing angle GS 160.3 – GS 250.3	Standard: Adjustable 80° – 100°; set in the factory to 92° unless ordered otherwise. Options: Adjustable in steps of: 20° – 40°, 40° – 60°, 60° – 80°, For version with worm wheel made of bronze: swing angle > 100°, Multi-turn version without end stops, version GSD ³⁾											
Mechanical position indicator	Standard: Pointer cover for continuous position indication Options: Sealed pointer cover for horizontal outdoor installation ⁴⁾ Protection cover for buried service instead of pointer cover											
Input shaft	Cylindrical with parallel key according to DIN 6885.1											
Operation												
Motor operation	With electric multi-turn actuator, directly or through primary reduction gearing VZ/GZ Flanges for mounting of actuator, refer also to separate technical data sheets.											
Type of duty	According to actuator											
Manual operation ⁵⁾	Via handwheel, directly or through primary reduction gearing VZ/GZ Available handwheel diameters, selection according to the max. output torque:											
	Type	GS 50.3	GS 63.3	GS 80.3	GS 100.3			GS 125.3				
	Reduction gearing	–	–	–	–	VZ 2.3	VZ 3.3	VZ 4.3	–	VZ 2.3	VZ 3.3	VZ 4.3
	Handwheel Ø mm	160 200 250	250 315	315 400	400 500	315 400	315 400	250 315	500 630 800	400 500	400 500	315 400
	Type	GS 160.3			GS 200.3			GS 250.3				
	Reduction gearing	–	GZ 160.3		–	GZ 200.3		–	GZ 250.3			
Handwheel Ø mm	630 800	400	315	–	500 630	400	315	–	800	500 630	400	
25.4 mm correspond to 1 inch												
<p>1) With worm wheel made of spheroidal cast iron</p> <p>2) Requires worm wheel made of bronze</p> <p>3) Special sizing is required</p> <p>4) For gas applications with sealed pointer cover, an air vent in the pointer cover or venting grooves in the valve mounting flange must be provided</p> <p>5) Handwheel sizes shown reflect general industrial selection criteria. For information on gearbox/handwheel selection in accordance with AWWA Standard C504, please refer to separate selection list/chart.</p>												

Primary reduction gearing																																																		
Primary reduction gearing	Planetary gear with various reduction ratios for reducing the input torques																																																	
Valve attachment																																																		
Valve attachment	Dimensions according to SP 101 Standard: GS 50.3 – GS 125.3: without spigot GS 160.3 – GS 250.3: without spigot Options: GS 50.3 – GS 125.3: with spigot GS 160.3 – GS 250.3: with spigot																																																	
Splined coupling for connection to the valve shaft	Standard: without bore or pilot bore from GS 160.3 Worm gearbox can be repositioned 4 x 90° on coupling Options: Machined with bore and keyway, square bore or bore with two-flats																																																	
Service conditions																																																		
Enclosure protection according to EN 60 529 ⁶⁾	Standard: IP 68-3, dust and water tight up to max. 3 m head of water Options ⁷⁾ : IP 68-6, dust and water tight up to max. 6 m head of water IP 68-10, dust and water tight up to max. 10 m head of water IP 68-20, dust and water tight up to max. 20 m head of water																																																	
Corrosion protection	Standard: KN Suitable for installation in industrial units, in water or power plants with a low pollutant concentration Options: KS Suitable for installation in occasionally or permanently aggressive atmosphere with a moderate pollutant concentration (e.g. in wastewater treatment plants, chemical industry) KX Suitable for installation in extremely aggressive atmosphere with high humidity and high pollutant concentration																																																	
Paint	Standard: GS 50.3 – GS 125.3: Two-component iron-mica combination GS 160.3 – GS 250.3: Two-component iron-mica combination																																																	
Color	Standard: Grey (DB 702, similar to RAL 9007) Option: Other colors on request																																																	
Ambient temperature	Standard: – 20 °F to + 175 °F / – 25 °C to + 80 °C Options: – 40 °F to + 140 °F / – 40 °C to + 60 °C (low temperature), version L – 75 °F to + 140 °F / – 60 °C to + 60 °C (extreme low temperature), version EL + 32 °F to + 250 °F / – 0 °C to + 120 °C (high temperature), version H																																																	
Lifetime	Open-close duty: The lifetime is based on a load profile typical for part-turn valves <table border="1" style="margin-left: 20px;"> <thead> <tr> <th rowspan="2">Type</th> <th colspan="4">Operating cycles (OPEN - CLOSE - OPEN) for swivel movements of 90° (max. 100°) and a maximum output torque of</th> </tr> <tr> <th>100 %</th> <th>140 %</th> <th>175 %⁸⁾</th> <th>200 %⁹⁾</th> </tr> </thead> <tbody> <tr> <td>GS 50.3</td> <td>15,000</td> <td>5,000</td> <td>–</td> <td>1,000</td> </tr> <tr> <td>GS 63.3</td> <td>15,000</td> <td>5,000</td> <td>–</td> <td>1,000</td> </tr> <tr> <td>GS 80.3</td> <td>15,000</td> <td>5,000</td> <td>–</td> <td>1,000</td> </tr> <tr> <td>GS 100.3</td> <td>15,000</td> <td>5,000</td> <td>–</td> <td>1,000</td> </tr> <tr> <td>GS 125.3</td> <td>15,000</td> <td>5,000</td> <td>–</td> <td>1,000</td> </tr> <tr> <td>GS 160.3</td> <td>15,000</td> <td>5,000</td> <td>1,000</td> <td>–</td> </tr> <tr> <td>GS 200.3</td> <td>15,000</td> <td>5,000</td> <td>1,000</td> <td>–</td> </tr> <tr> <td>GS 250.3</td> <td>10,000</td> <td>3000</td> <td>750</td> <td>–</td> </tr> </tbody> </table> Modulating duty: min. 2.5 million operations ⁸⁾	Type	Operating cycles (OPEN - CLOSE - OPEN) for swivel movements of 90° (max. 100°) and a maximum output torque of				100 %	140 %	175 % ⁸⁾	200 % ⁹⁾	GS 50.3	15,000	5,000	–	1,000	GS 63.3	15,000	5,000	–	1,000	GS 80.3	15,000	5,000	–	1,000	GS 100.3	15,000	5,000	–	1,000	GS 125.3	15,000	5,000	–	1,000	GS 160.3	15,000	5,000	1,000	–	GS 200.3	15,000	5,000	1,000	–	GS 250.3	10,000	3000	750	–
Type	Operating cycles (OPEN - CLOSE - OPEN) for swivel movements of 90° (max. 100°) and a maximum output torque of																																																	
	100 %	140 %	175 % ⁸⁾	200 % ⁹⁾																																														
GS 50.3	15,000	5,000	–	1,000																																														
GS 63.3	15,000	5,000	–	1,000																																														
GS 80.3	15,000	5,000	–	1,000																																														
GS 100.3	15,000	5,000	–	1,000																																														
GS 125.3	15,000	5,000	–	1,000																																														
GS 160.3	15,000	5,000	1,000	–																																														
GS 200.3	15,000	5,000	1,000	–																																														
GS 250.3	10,000	3000	750	–																																														

6) Refer to section enclosure protection IP 68

7) Not available for GS 50.3

8) With worm wheel made of spheroidal cast iron

9) The lifetime for modulating duty depends on the load and the number of starts. A high starting frequency will rarely improve the modulating accuracy. To reach the longest possible maintenance and fault-free operation time, the number of starts per hour chosen should be as low as permissible for the process

Accessories	
Valve position indicators	Valve position indicator WSG for the signalization of intermediate and end positions for precise and low-backlash feedback for swing angles ranging from 82° – 98° (refer to separate data sheet)
	Valve position indicator WGD for signalization of intermediate and end positions for swing angles > 180° (refer to separate data sheet)
Limit switching	Limit switching WSH for manually operated valves. For the signalization of intermediate and end positions (refer to separate data sheet)
Further information	
Reference documents	Product description Worm gearboxes GS 50.3 – GS 250.3 /GS 315 – GS 500 Dimension sheets GS 50.3 – GS 125.3, GS 160.3 – GS 250.3 Technical data GS 50.3 – GS 125.3, GS 160.3 – GS 250.3 Technical data SA, SAR, WSG, WGD, WSH
Lever gearboxes	See separate documents

3. Transport, storage and packaging

3.1 Transport

- Transport to place of installation in sturdy packing.
- If mounted together with actuator:
Attach ropes or hooks for the purpose of lifting by hoist only to the gearbox and not to the actuator.
- If eyebolts are supplied with the gearbox, they should be used to lift the gearbox only and not the valve

3.2 Storage

- Store in well-ventilated, dry room.
- Protect against floor dampness by storage on a shelf or on a wooden pallet.
- Cover to protect against dust and dirt.
- Apply suitable corrosion protection agent to bare surfaces.

In case worm gearboxes are to be stored for a long period (more than 6 months), the following points must be observed additionally:

- Prior to storage: Protect bare surfaces, in particular the output drive parts and mounting surface, with long-term corrosion protection agent.
- Check for corrosion approximately every 6 months. If first signs of corrosion show, apply new corrosion protection.

3.3 Packaging

Our products are protected by special packaging for the transport ex works. The packaging consists of environmentally friendly materials which can easily be separated and recycled. For the disposal of the packaging material, we recommend recycling and collection centers.

4. Fitting the handwheel

For worm gearboxes designed for manual operation the handwheel may be supplied separately. Fitting is done on site according to figure A.

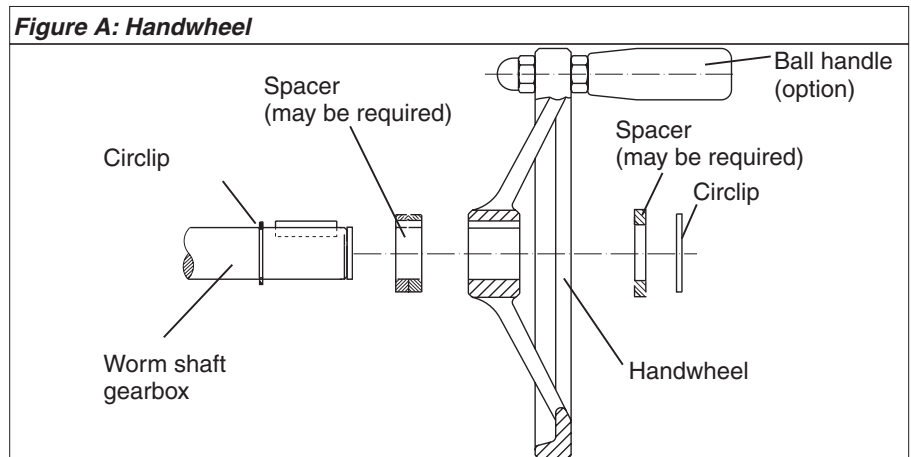

5. Mounting positions of the different versions

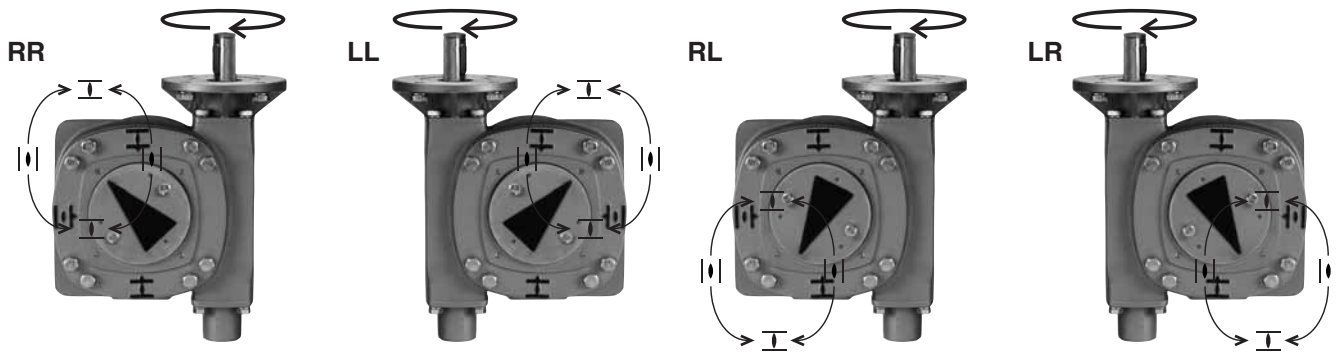

Description of the 4 versions (viewed at the pointer cover):

Code	Direction of rotation at input shaft	Position of worm shaft	Direction of rotation at output drive
RR	clockwise	Right side	clockwise
LL	clockwise	Left side	counterclockwise
RL	clockwise	Right side	counterclockwise
LR	clockwise	Left side	clockwise

Mounting positions of AUMA multi-turn actuator with AUMA worm gearbox (please indicate when ordering)
GS versions RR / RL

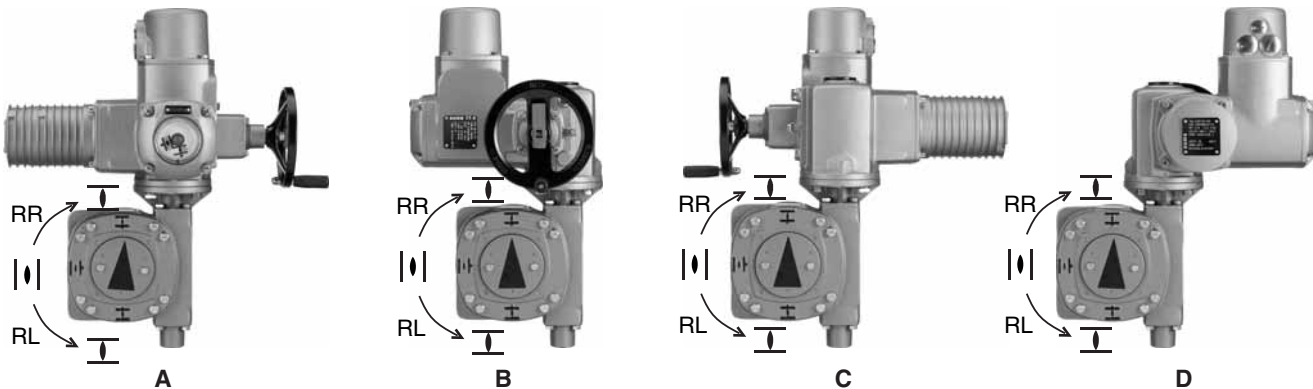

GS versions LL / LR

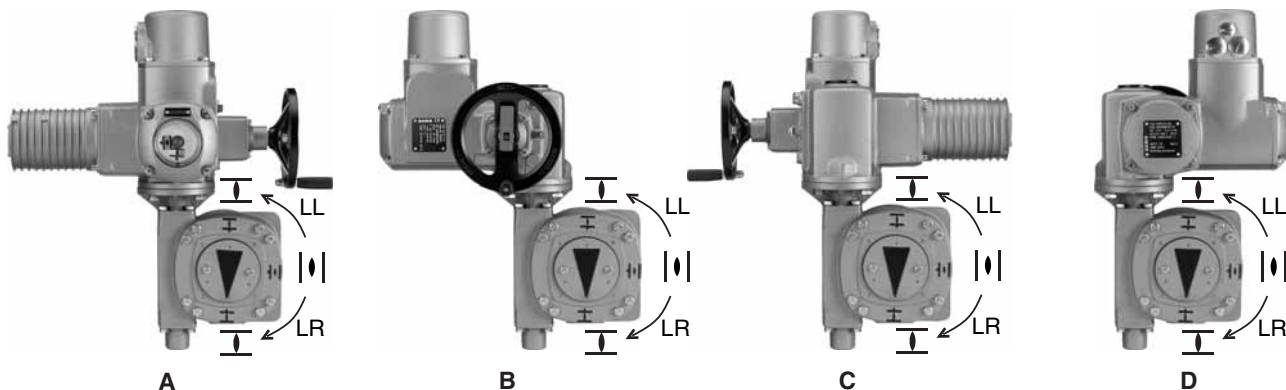

Mounting positions can easily be changed at a later date.

Limitation: For SA/SAR 14.1/14.5 with GS 125.3, mounting position “C” in version RR/RL and “A” in version LL/LR is only possible for a handwheel diameter up to 12.4 ”.

Up to size GS 125.3, the actuator-gearbox combination is delivered in the ordered mounting position. For packing reasons, actuator and gearbox is delivered separately from size GS 160.3.

6. Mounting multi-turn actuators SA/SAR

When gearboxes and multi-turn actuators are supplied together, the mounting has been done in the factory up to gearbox size GS 125.3. For sizes GS 160.3 and larger, the mounting of gearboxes is performed as follows.

In case flange for actuator is not attached to gearbox or reduction gearing:

- Thoroughly degrease the mounting faces of the gearbox or reduction gearing as well as the flange for actuator.
- For GS 100.3 – GS 250.3:
Insert pin in the corresponding groove of the bearing cover.
- Fit flange for actuator and fasten with bolts and lock washers.
- Fasten bolts crosswise with a torque according to table 2.

Figure B: Mounting multi-turn actuator to worm gearbox

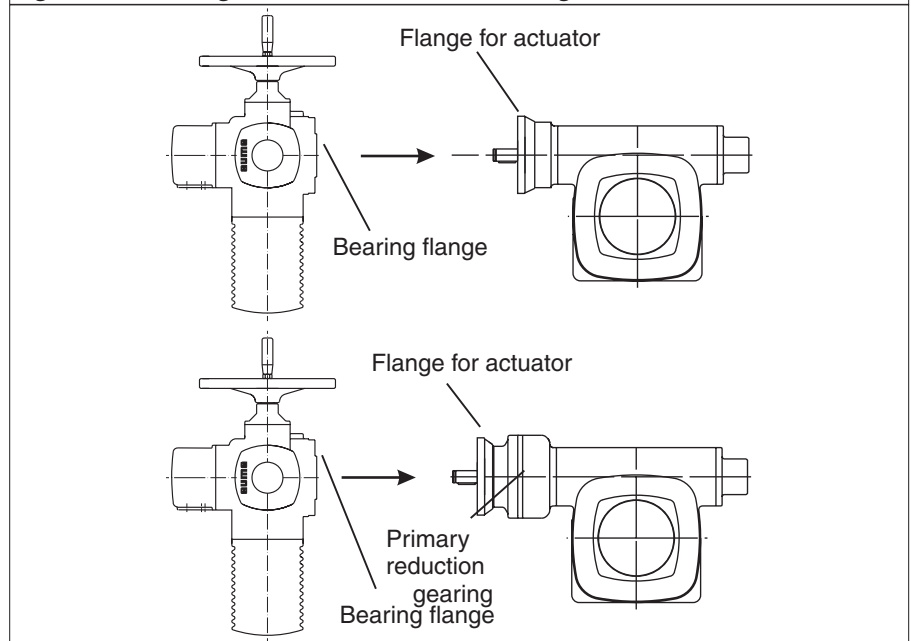

Mounting the multi-turn actuator:

- Thoroughly degrease the faces of the flange for actuator at the gearbox or reduction gearing as well as the actuator's bearing flange.
- Place the multi-turn actuator on the worm gearbox or reduction gearing. The multi-turn actuator can be mounted on the valve at every 90° (see page 8, mounting positions).
- Ensure that the spigot mates uniformly in the recess and that the mounting faces are in complete contact.
- Fasten actuator with bolts and lock washers (see table 1) at the flange of the worm gearbox.
- Fasten bolts crosswise with a torque according to table 2.



Do not attach ropes or hooks for the purpose of lifting the actuator by hoist to the handwheel. If multi-turn actuator is mounted on gearbox, attach ropes or hooks for the purpose of lifting by hoist to gearbox and not to multi-turn actuator.

Table 1: Bolts for mounting AUMA actuators to worm gearboxes/ primary reduction gearing (strength class min. 8.8)

Worm gearbox/ primary reduction gearing	SA(R) 07.1-FA10			SA(R) 07.5-FA10		
	Bolt (UNC)	Lock washer	Qty.	Bolt (UNC)	Lock washer	Qty.
GS 50.3	3/8-16x1	3/8	4			
GS 63.3	3/8-16x1	3/8	4	3/8-16x1	3/8	4
GS 80.3				3/8-16x1	3/8	4
GS 100.3						
GS 100.3/VZ	3/8-16x1	3/8	4	3/8-16x1	3/8	4
GS 125.3						
GS 125.3/VZ				3/8-16x1	3/8	4
GS 160.3						
GS 160.3/GZ	3/8-16x1	3/8	4	3/8-16x1	3/8	4
GS 200.3						
GS 200.3/GZ	3/8-16x1	3/8	4	3/8-16x1	3/8	4

Worm gearbox/ primary reduction gearing	SA(R) 10.1-FA10			SA(R) 14.1-FA14			SA(R) 14.5-FA14			SA(R) 16.1-FA16		
	Bolt (UNC)	Lock washer	Qty.	Bolt (UNC)	Lock washer	Qty.	Bolt (UNC)	Lock washer	Qty.	Bolt (UNC)	Lock washer	Qty.
GS 63.3	3/8-16x1	3/8	4									
GS 80.3	3/8-16x1	3/8	4									
GS 100.3	3/8-16x1	3/8	4	5/8-11x1½	5/8	4						
GS 100.3/VZ	3/8-16x1	3/8	4									
GS 125.3				5/8-11x1½	5/8	4	5/8-11x1½	5/8	4			
GS 125.3/VZ	3/8-16x1	3/8	4	5/8-11x1½	5/8	4						
GS 160.3							5/8-11x1½	5/8	4	¾-10x2	3/4	4
GS 160.3/GZ	3/8-16x1	3/8	4	5/8-11x1½	5/8	4						
GS 200.3										¾-10x2	3/4	4
GS 200.3/GZ	3/8-16x1	3/8	4	5/8-11x1½	5/8	4	5/8-11x1½	5/8	4			
GS 250.3												
GS 250.3/GZ	3/8-16x1	3/8	4	5/8-11x1½	5/8	4	5/8-11x1½	5/8	4	¾-10x2	3/4	4

Worm gearbox/ primary reduction gearing	SA(R) 25.1-FA25			SA(R) 30.1-FA30		
	Bolt (UNC)	Lock washer	Qty.	Bolt (UNC)	Lock washer	Qty.
GS 160.3						
GS 160.3/GZ						
GS 200.3	5/8-11x2	5/8	8			
GS 200.3/GZ						
GS 250.3	5/8-11x2	5/8	8	¾-10x2	3/4	8
GS 250.3/GZ						

7. Mounting to valve

AUMA worm gearboxes GS and primary reduction gearings VZ/GZ can be operated in any mounting position.

- For **butterfly valves**, the recommended mounting position is end position CLOSED
(Prior to mounting, bring the gearbox to the mechanical end stop CLOSED by turning the handwheel clockwise).
- For **ball valves**, the recommended mounting position is end position OPEN
(Prior to mounting, bring the gearbox to the mechanical end stop OPEN by turning the handwheel counterclockwise).
- Alternatively, the limit stop housing can be turned up to the end position of the respective valve.
- Thoroughly degrease mounting faces of gearbox and valve.
- Place coupling sleeve onto valve shaft and secure (refer to figure C, detail A or B), ensure that dimensions X, Y, and Z are observed (refer to table 2).
- Apply non-acidic grease at splines of coupling.
- Mount gearbox on valve. Ensure that the spigot (if provided) mates uniformly in the recess and that the mounting faces are in complete contact.
- Fasten gearbox with bolts (quality min. 8.8) and lock washers.
- Fasten bolts crosswise with a torque according to table 2.

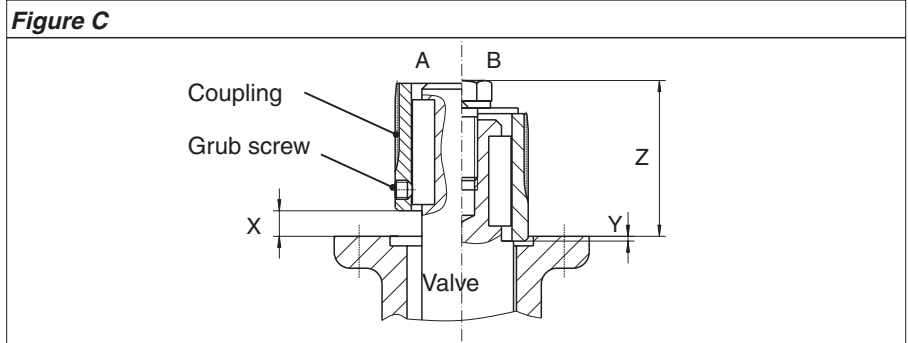

Table 2: Standard dry fastening torques for bolts

Gearbox	Dimensions			Bolts	Strength class Grade 5	
	Flange type	X max	Y max			Z max
GS 50.3-FA10		14	5	61	4 x 3/8 - 16	33
GS 63.3-FA10		7	18	73	4 x 3/8 - 16	33
GS 63.3-FA12		10	13	76	4 x 1/2 - 13	78
GS 80.3-FA14		23	5	88	4 x 5/8 - 11	155
GS 100.3-FA14		22	13	123	4 x 5/8 - 11	155
GS 100.3-FA16		22	8	123	4 x 3/4 - 10	257
GS 125.3-FA16		17	35	126	4 x 3/4 - 10	257
GS 125.3-FA25		17	27	126	8 x 5/8 - 11	155
GS 160.3-FA25		15	11	130	8 x 5/8 - 11	155
GS 160.3-FA30		30	0	140	8 x 3/4 - 10	255
GS 200.3-FA30		19	19	160	8 x 3/4 - 10	255
GS 200.3-FA35		44	0	190	8 x 1 - 8	590
GS 250.3-FA35		8	8	220	8 x 1 - 8	590
GS 250.3-FA40		13	0	230	8 x 1 1/4 - 7	1,200

Note:

Experience showed that it is very difficult to fasten bolts or nuts of 1-8 UNC or larger with the defined torques. The worm gearbox may be moved radially against the valve flange by accident.

To improve adhesion between valve and gearbox, we recommend to apply Loctite 243 (or similar products) on mounting faces.

11. Enclosure protection IP 68

Definition

According to EN 60 529, the conditions for meeting the requirements of enclosure protection IP 68 (requirements exceed those of IP 67) are to be agreed between manufacturer and user. AUMA worm gearboxes and primary reduction gearings in enclosure protection IP 68 meet the following requirements according to AUMA:

- IP 68-3, submersible in water up to 3 m head of water
- IP 68-6, submersible in water up to 6 m head of water
- IP 68-10, submersible in water up to 10 m head of water
- IP 68-20, submersible in water up to 20 m head of water

For size GS 50.3, only enclosure protection IP 68-3 is available.

If submersed in other media, additional measures for corrosion protection may be necessary; please consult AUMA. Submersion in aggressive media, e.g. acids or alkaline solutions, is not permitted.

Review

Gearboxes in enclosure protection IP 68-3 were type tested in the factory. Gearboxes in enclosure protection IP 68-6, IP 68-10 and IP 68-20 undergo a routine testing for tightness in the factory.

Note:

- The enclosure protection IP 68 refers to the interior of the gearboxes, but not to the coupling compartment.
- If the gearboxes are likely to be repeatedly submersed, a higher corrosion protection KS or KX is required.
- For gearboxes intended for buried service we strongly recommend to use the higher corrosion protection KS or KX.
- For horizontal outdoor installation of the gearboxes, a sealed pointer cover should be used.
For gas applications with sealed pointer cover, an air vent in the pointer cover or venting grooves in the valve mounting flange must be provided.
- In case of permanent submersion of the gearboxes or for buried service, a protection cover must be fitted instead of a pointer cover. This will be taken into account in the factory if indicated on the purchase order. Subsequent exchange of the pointer cover for the protection cover is possible.
- Use suitable sealing material between valve flange and gearbox.
- Water can enter into the coupling compartment along the valve shaft. This would lead to corrosion of hub and coupling. Therefore a suitable anticorrosive (or sticky grease) must be applied to the hub and coupling of the gearbox before mounting.
- With corrosion protection KX, the hub and coupling are provided with a high quality corrosion protection as standard.



Solutions for a world in motion

North American Sales and Service:

US Headquarters and Factory:

AUMA Actuators, Inc.

100 Southpointe Blvd.
Canonsburg PA 15317
Tel: 724-743-AUMA (2862)
Fax: 724-743-4711
email: mailbox@auma-usa.com
www.auma-usa.com

Regional Offices:

Northeast (Maryland and New York)
Southeast (South Carolina)
Midwest (Illinois)
Midwest (Kansas)
Houston (Texas)
West Coast (Northern and Southern California)

Representatives and Distributors

Anchorage
Atlanta
Baltimore
Baton Rouge
Birmingham
Boston
Charlotte
Chicago
Cincinnati
Corpus Christi
Dallas
Denver
Detroit
Hawaii
Houston
Indianapolis
Kansas City
Los Angeles
Mexicali (Mexico)
Mexico City
Milwaukee
Minneapolis
Montana
Monterrey (Mexico)
New York
Omaha
Orlando
Philadelphia
Phoenix
Pittsburgh
Rochester
Salt Lake City
San Diego
San Francisco
San Juan
Seattle
St. Louis
Toronto
Tulsa

International Headquarters:

AUMA Riester GmbH & Co. KG

Müllheim/ Germany
www.auma.com

International Sales and Service:

South America:

Argentina
Brazil
Chile
Colombia
Peru
Venezuela

Europe:

Austria
Benelux
Czech Republic
Denmark
Finland
France
Greece
Hungary
Italy
Norway
Poland
Portugal
Russia
Spain
Sweden
Switzerland
Turkey
Ukraine
United Kingdom

Africa

Egypt
South Africa

Asia, Australia

Australia
China
Hong Kong
India
Japan
Korea
Kuwait
Oman
Qatar
Singapore
Taiwan
Thailand
UAE

For the name and phone number of the office nearest you, call us at 724-743-2862 or visit our website at www.auma-usa.com/saleserv.htm

2005-06-27



Catalogs > Automation Systems Catalog > Programmable Controllers > CompactLogix System > Controllers

CONTROLLERS

Introduction	CompactLogix Controllers	1769-L23x System	1769-L3x System	1768-L4x System	Compatibility	
--------------	-------------------------------------	---------------------	--------------------	--------------------	---------------	--

CompactLogix Controllers

Standard Controller Modules

Characteristic	1769-L31	1769-L32C	1769-L32E	1769-L35CR	1769-L35E	1768-L43	1768-L45
Available User Memory	512 KB	750 KB	750 KB	1.5 MB	1.5 MB	2 MB	3 MB
CompactFlash Card	<ul style="list-style-type: none"> • 1784-CF64 64 MB • 1784-CF128 128 MB 	<ul style="list-style-type: none"> • 1784-CF64 64 MB • 1784-CF128 128 MB 	<ul style="list-style-type: none"> • 1784-CF64 64 MB • 1784-CF128 128 MB 	<ul style="list-style-type: none"> • 1784-CF64 64 MB • 1784-CF128 128 MB 	<ul style="list-style-type: none"> • 1784-CF64 64 MB • 1784-CF128 128 MB 	<ul style="list-style-type: none"> • 1784-CF64 64 MB • 1784-CF128 128 MB 	<ul style="list-style-type: none"> • 1784-CF64 64 MB • 1784-CF128 128 MB
Communication Ports	2 RS-232 ports (isolated DF1 or ASCII; non-isolated DF1 only)	1 ControlNet port and 1 RS-232 serial port (DF1 or ASCII)	1 EtherNet/IP port and 1 RS-232 serial port (DF1 or ASCII)	1 ControlNet port and 1 RS-232 serial port (DF1 or ASCII)	1 EtherNet/IP port and 1 RS-232 serial port (DF1 or ASCII)	1 RS-232 port	1 RS-232 port
Backplane Current @ 5V	330 mA	680 mA	660 mA	680 mA	660 mA	0 A 1768 output • 2.8 A @ 5.2V 1769 output • 2.0 A @ 5.2V	0 A 1768 output • 5.6 A @ 5.2V 1769 output • 2.0 A @ 5.2V
Backplane Current @ 24V	40 mA	40 mA	90 mA	40 mA	90 mA	1.3 A 1769 output • 1.0 A @ 24V	1.3 A 1769 output • 1.0 A @ 24V
Power Dissipation	2.61 W	4.36 W	4.74 W	4.36 W	4.74 W	6.3 W	6.3 W
Module Expansion Capacity	16 1769 modules	16 1769 modules	16 1769 modules	30 1769 modules	30 1769 modules	• Two 1768 modules • 16 1769 modules	• Four 1768 modules • 30 1769 modules
Power Supply Distance Rating	4 modules	4 modules	4 modules	4 modules	4 modules	NA	NA

Packaged Controllers with Embedded I/O

Characteristic	1769-L23-QBFC1B	1769-L23E-QB1B	1769-L23E-QBFC1B
Available User Memory	512 KB	512 KB	512 KB
CompactFlash Card	None	None	None
Communication Ports	2 RS-232 ports (isolated DF1 or ASCII; non-isolated DF1 only)	1 EtherNet/IP port and 1 RS-232 serial port (DF1 or ASCII)	1 EtherNet/IP port and 1 RS-232 serial port (DF1 or ASCII)
Embedded I/O	<ul style="list-style-type: none"> • 16 DC inputs • 16 DC outputs • 4 analog inputs • 2 analog outputs • 4 high-speed counters 	<ul style="list-style-type: none"> • 16 DC inputs • 16 DC outputs 	<ul style="list-style-type: none"> • 16 DC inputs • 16 DC outputs • 4 analog inputs • 2 analog outputs • 4 high-speed counters
Module Expansion Capacity	Up to two additional 1769 modules	Up to two additional 1769 modules	Up to two additional 1769 modules
Embedded Power Supply	24V DC	24V DC	24V DC

Estimate Controller Memory Use

The following equations provide an estimate of the memory needed for a controller.

Controller Tasks	_____ * 4000	=	_____ bytes (minimum 1 task)
Digital I/O points	_____ * 400	=	_____ bytes
Analog I/O points	_____ * 2600	=	_____ bytes
Communication modules*	_____ * 2000	=	_____ bytes
Motion axes	_____ * 8000	=	_____ bytes
FactoryTalk alarm instruction	_____ * 1000	=	_____ bytes (per alarm)
FactoryTalk subscriber	_____ * 10000	=	_____ bytes (per subscriber)

* When estimating memory use by communication modules, count all the communication modules in the system, not just those in the local chassis. This includes device connection modules, adapter modules, and ports on PanelView terminals.

CompactFlash Card

The CompactFlash card offers nonvolatile memory (flash) to permanently store a user program and tag data on a controller. The 1769-L3x and 1768-L4x controllers support a CompactFlash card.

- 1784-CF64 has 64 MB of memory.
- 1784-CF128 has 128 MB of memory.

Controller Battery

The 1769-L23x and 1769-L3x controllers come with one 1769-BA lithium battery.

The 1768 controller **does not** require a battery. The controller uses internal flash memory to store its program during shutdown. Energy stored in the 1768 power supply maintains controller power long enough to store the program to internal flash memory (not the external CompactFlash card).

Copyright © 2010 Rockwell Automation, Inc. All Rights Reserved.

- “Designed for touch” from the ground up
- Elo reliability and quality at an economical price point
- 3 year warranty



1537L 15” LCD Open-Frame Touchmonitor

The Elo 1537L open-frame LCD touchmonitor complements the Elo expanding family of touch solutions for kiosk information systems, gaming and amusement, and light industrial shop-floor automation. This compact touchmonitor is “designed for touch,” with proven Elo expertise and reliability built in. An integrated precision mini-bezel seals the touchscreen against dirt, dust and liquids, which simplifies integration into the final enclosure. Long-lasting product availability can be expected as the design and tooling is controlled by Elo specifications, allowing future-generation panels to be phased in without external changes.

The 1537L is available with a choice of industry-leading touch technologies, in both single touch and multi touch versions. Seamless zero-bezel versions include IntelliTouch Pro projected capacitive and IntelliTouch Zero-Bezel surface acoustic wave. Standard bezel options include AccuTouch five-wire resistive, CarrollTouch infrared, IntelliTouch and SecureTouch anti-vandal surface acoustic wave. Worldwide agency approvals cover the whole monitor, which is developed, built, serviced and supported by a true single source supplier. The 1537L open-frame LCD touchmonitor provides an economical solution for system integrators and VARs.



Benefits

- Choice of Elo touch technologies:
 - Standard bezel versions: AccuTouch resistive; CarrollTouch infrared, IntelliTouch and IntelliTouch Plus surface acoustic wave
 - Zero-Bezel versions: IntelliTouch Zero-Bezel surface acoustic wave, IntelliTouch Pro projected capacitive
- Touchscreen sealed against dirt, dust and liquids
- Compact and easy to integrate with mounting from sides or top and bottom; also a VESA mount option
- Worldwide agency approvals
- Three year standard warranty

Applications

- Kiosk information systems
- Gaming and amusement
- Light industrial shop-floor automation

About Elo

Elo founders pioneered the touch screen over 40 years ago. Today, Elo Touch Solutions is a leading global supplier of touch-enabled technology, products and industry solutions. The Elo portfolio encompasses the broadest selection of OEM touchscreen components, touchmonitors, and all-in-one touchcomputers for the demanding requirements of diverse markets, including gaming machines, hospitality systems, industrial automation, interactive kiosks, healthcare, office equipment, point of sale terminals, retail displays, and transportation applications. The Elo touch experience has consistently stood for quality, reliability and innovation with over 20 million installations worldwide.

1537L 15" Open-Frame Touchmonitor Specifications

Case/Bezel color	Steel/black		
Display type	Active matrix TFT LCD with LED backlighting		
Display size	15.0" diagonal		
Aspect ratio	4:3		
Useful screen area	Horizontal: 12" (304 mm); Vertical: 9" (228 mm)		
Monitor dimensions	Width: 13.2" (336 mm) Height: 10.4" (264 mm) Depth: 1.6" (41 mm)	IntelliTouch ZB: Width: 14.3" (364mm) Height: 11.5" (291mm) Depth: 1.6" (41.5mm)	IntelliTouch Pro Width: 14.29" (363mm) Height: 11.4" (290mm) Depth: 1.1" (29mm)
Optimal (native) resolution	1024 x 768		
Other supported resolutions	1024 x 768 at 60, 65 (Sun), 70, or 75 Hz; 832 x 624 at 75 Hz (Mac); 800 x 600 at 56, 60, 72, or 75 Hz; 720 x 400 at 70 Hz; 720 x 350 at 70 Hz; 640 x 480 at 60, 66 (Mac), 72, or 75 Hz		
Colors	16.2 million colors with dithering		
Brightness (typical)	LCD Panel: 250 nits; AccuTouch: 200 nits; IntelliTouch: 225 nits; IntelliTouch Plus: 225 nits; SecureTouch: 225 nits; CarrollTouch: 225 nits; IntelliTouch Zero-Bezel: 225 nits; IntelliTouch Pro: 225 nits		
Response time (typical)	16 msec		
Viewing angle (from center)	Horizontal (left/right): ±80° or 160° total Vertical (up/down): ±70° or 140° total		
Contrast ratio (typical)	700:1		
Input video format	Analog VGA and Digital DVI		
Input video signal connector	Female DE-15 connector, Female DVI-D, Dual-Link connector		
Scanning frequency	Horizontal: 31.5 - 60.2 kHz; Vertical: 56.3 - 75 Hz		
Power supply	External DC—optional power brick (sold separately) Input voltage—DC: +12VDC ±5% at 2.5 A max. Input power connector specification (on monitor)—Type: DC Barrel Jack; Barrel inner diameter: 6.4 mm (±0.3 mm); Pin outer diameter: 2.0 mm (+0.0 -0.1 mm); Barrel depth: 8.8 mm (±0.3 mm) Power connector (on power brick)—Type: DC Barrel Plug; Barrel outer diameter: 5.5 mm (±0.1 mm); Pin inner diameter: 2.1 mm (±0.1 mm); Barrel length: 9.5 mm (±0.5 mm)		
Power Consumption (typical)	Monitor only: 13.5W		
Temperature	Operating: 0°C to 40°C; Storage: -20°C to 60°C		
Humidity	Operating: 20% to 80% (non-condensing); Storage: 10% to 90% (non-condensing)		
MTBF	50,000 hours demonstrated		
Weight (approx.)	Actual: 6.6 lbs (3.0 kg); Shipping: 9.7 lbs (4.4 kg) IntelliTouch Pro: Actual: 5.7 lbs (2.6kg); Shipping: 8.8 lbs (4 kg)		
Warranty	3 years		
On-screen display (OSD)	Digital OSD or Remote OSD with 1.8m cable		
User's controls	OSD buttons: menu, up, down, select, power; OSD: contrast, brightness, H/V position, RGB (color temp), clock, phase, recall, language (English, German, Spanish, Japanese, French); OSD disable/enable: power, OSD menu		
Mounting options	100 mm or 75 mm VESA mount; open-frame with brackets; mounting brackets included		
Agency Certification	UL, cUL (Recognized), FCC, CE, VCCI, IC, C-TICK, CCC, BSMI, KC, China RoHS		

Ordering Information

Model	Part Number	Technology	Interface	Surface Treatment	Availability
1537L	E701210	AccuTouch	Dual serial/USB	Antiglare	Worldwide
	E461378	CarrollTouch	Dual serial/USB	Antiglare	Worldwide
	E512043	IntelliTouch	Dual serial/USB	Antiglare	Worldwide
	E731919	SecureTouch	Dual serial/USB	Antiglare	Worldwide
	E419638	IntelliTouch Plus	USB	Clear	Worldwide
	E001124	IntelliTouch Zero-Bezel single touch	Dual serial/USB	Clear	Worldwide
	E001123	IntelliTouch Zero-Bezel dual touch	USB	Clear	Worldwide
	E001122	IntelliTouch Pro	USB	Clear	Worldwide

To find out more about our extensive range of Elo touch solutions, go to www.elotouch.com, or call the office nearest you.

North America

Elo Touch Solutions
1033 McCarthy Boulevard
Milpitas, CA 95035

800-ELO-TOUCH

Tel +1 408 597 8000

Fax +1 408 597 8001

customerservice@elotouch.com

Europe

Tel +32 (0)16 70 45 00

Fax +32 (0)16 70 45 49

elosales@elotouch.com

Asia-Pacific

Tel +86 (21) 3329 1385

Fax +86 (21) 3329 1400

www.elotouch.com.cn

Latin America

Tel 786-923-0251

Fax 305-931-0124

www.elotouch.com

Elo Touch Solutions, Inc. reserves the right to change or update, without notice, any information contained herein; to change, without notice, the design, construction, materials, processing or specifications of any products; and to discontinue or limit production or distribution of any products. Elo (logo) and Elo Touch Solutions are trademarks of Elo Touch Solutions, Inc. Copyright 2015 Elo Touch Solutions, Inc. All rights reserved. DS000022, rev C 02/15



Hach sc200™ Universal Controller

Controller—Multi-Parameter

Product Overview

One Controller for the Broadest Range of Sensors

The sc200 Universal Controller is the most versatile controller on the market. The sc200 controller allows the use of digital and analog sensors, either alone or in combination, to provide compatibility with the broadest range of sensors. It replaces the Hach sc100 digital and GLI53 analog controllers with advanced features for easier operator use.

The sc200 controller platform can be configured to operate either 2 Digital Sensor Inputs, or 1 or 2 Analog Sensor Inputs, or a combination of Digital and Analog Sensor Inputs. Customers may choose their communication options from a variety of offerings including MODBUS RTU, Profibus DPV1, and HART.



Choose from up to 29 digital or analog sensors for up to 15 different parameters.

Features and Benefits

Maximum Versatility

- Standardized controller eliminates the need for a variety of dedicated controllers
- Multi-channel controller operates either 1 or 2 sensors reducing inventory holding costs and providing an inexpensive option to add a second sensor at a later time
- “Plug and Play” operation with all Hach digital sensors
- True dual sensor controller provides 4-20 mA outputs to transmit primary and secondary measurement values

Ease of Use and Confidence in Results

- New display and guided calibration procedures reduce operator error
- Password protected SD card reader offers a simple solution for data download and transfer, and sc200 and digital sensor configuration file duplication and backup
- Visual warning system provides critical alerts



Communication Options

- MODBUS RS232/RS485, Profibus DPV1, or HART

- DW
- WW
- PW
- IW

Controller Configuration

2 Channel Digital Controller

Functionality

- Maximum versatility and flexibility:
- Plug and play with all Hach digital sensors
 - Mix and match with Hach digital and GLI analog sensors

2 Channel Controller with
1 Analog and 1 Digital Sensor Input

- Plug and play with any one Hach digital sensor
- Mix and match with any one GLI analog sensor

1 or 2 Channel Analog Controller

- Mix and match up to two GLI analog sensors

DW = drinking water WW = wastewater municipal PW = pure water / power
IW = industrial water E = environmental C = collections FB = food and beverage



Be Right™

Choose from Hach's Broad Range of Digital and Analog Sensors

Parameter	Sensor	Digital or Analog
Ammonia	AMTAX™ sc, NH4D sc	●
Chlorine	CLF10 sc, CLT10 sc, 9184 sc	●
Chlorine Dioxide	9185 sc	●
Conductivity	3400, 3700	△
Dissolved Oxygen	LDO™, 5740 sc	●
Dissolved Oxygen	5500	△
Flow	U53, F53 Sensors	△
Nitrate	NITRATAX™ sc, NO3D sc	●
Oil in Water	FP360 sc	●
Organics	UVAS sc	●
Ozone	9187 sc	●
pH/ORP	pHD	●
pH/ORP	pHD, pH Combination, LCP	△
Phosphate	PHOSPHAX™ sc	●
Sludge Level	SONATAX™ sc	●
Suspended Solids	SOLITAX™ sc, TSS sc	●
Turbidity	1720E, FT660 sc, SS7 sc, ULTRATURB sc, SOLITAX sc	●

● = Digital △ = Analog

The diagrams below demonstrate the versatility and flexibility for the base controller units. Connect any of the appropriate sensors listed above to meet your measurement needs. Operation of analog sensors require the controller to be equipped with the appropriate sensor card.

2 Channel Digital Controller Configurations

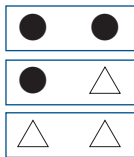

2 Channel Controller with 1 Analog and 1 Digital Sensor Input Configurations

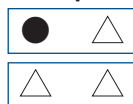

2 Channel Analog Controller Configurations



Engineering Specifications

- The controller shall be a microprocessor based instrument.
- The enclosure shall be 1/2 DIN format, NEMA4X rated for wall, pole and panel mounting.
- The controller shall be available in either 100–240 Vac 50/60 Hz or 24 Vdc power supply versions.
- The controller shall offer two analog 0/4-20 mA output signals with independent PID control functions and optional additional 4-20 mA outputs.
- The controller shall accept either Digital Sensors or Sensor Modules for analog pH, Conductivity, DO, Paddle Wheel Flow, and Ultra Sonic Flow sensors.
- The controller shall have single channel and dual channel options.
- The controller shall have options for MODBUS RS232, MODBUS RS485, Profibus DPV1, and HART 7.2 communication.
- The display contrast shall be adjustable.
- The Menu shall be available in at least 19 different languages.
- The controller shall have 2 Data logs, 128 kb each. The logged data shall be downloadable on a SD card in XML format.
- The controller shall be Hach Company sc200 Universal Controller.

Dimensions

The sc200 controller unit can be installed on a surface, panel, or horizontal or vertical pipe. Pipe Mount hardware is included.
 NOTE: Dimensions are in inches [millimeters].

Surface Mounting Dimensions

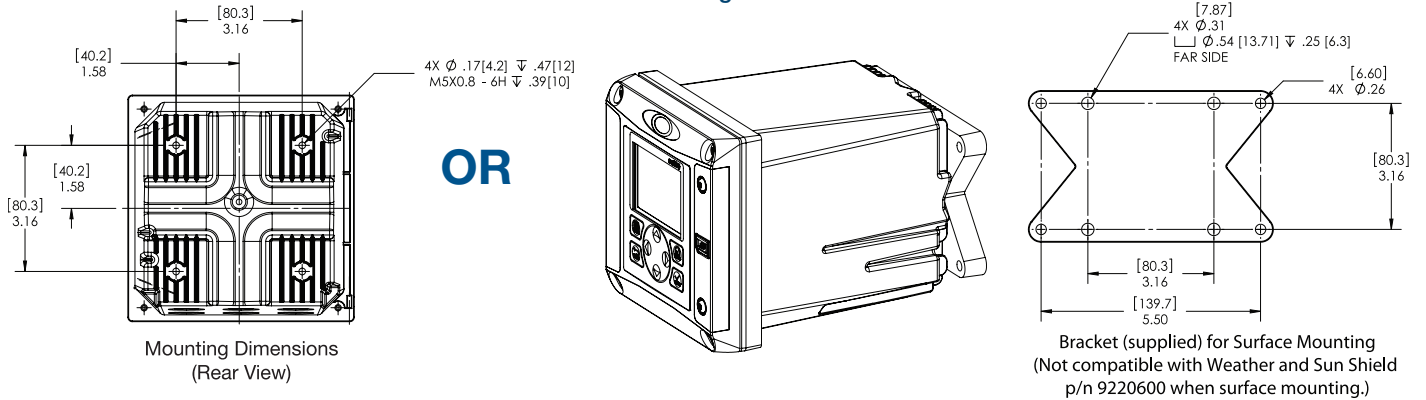

Panel Mounting Dimensions

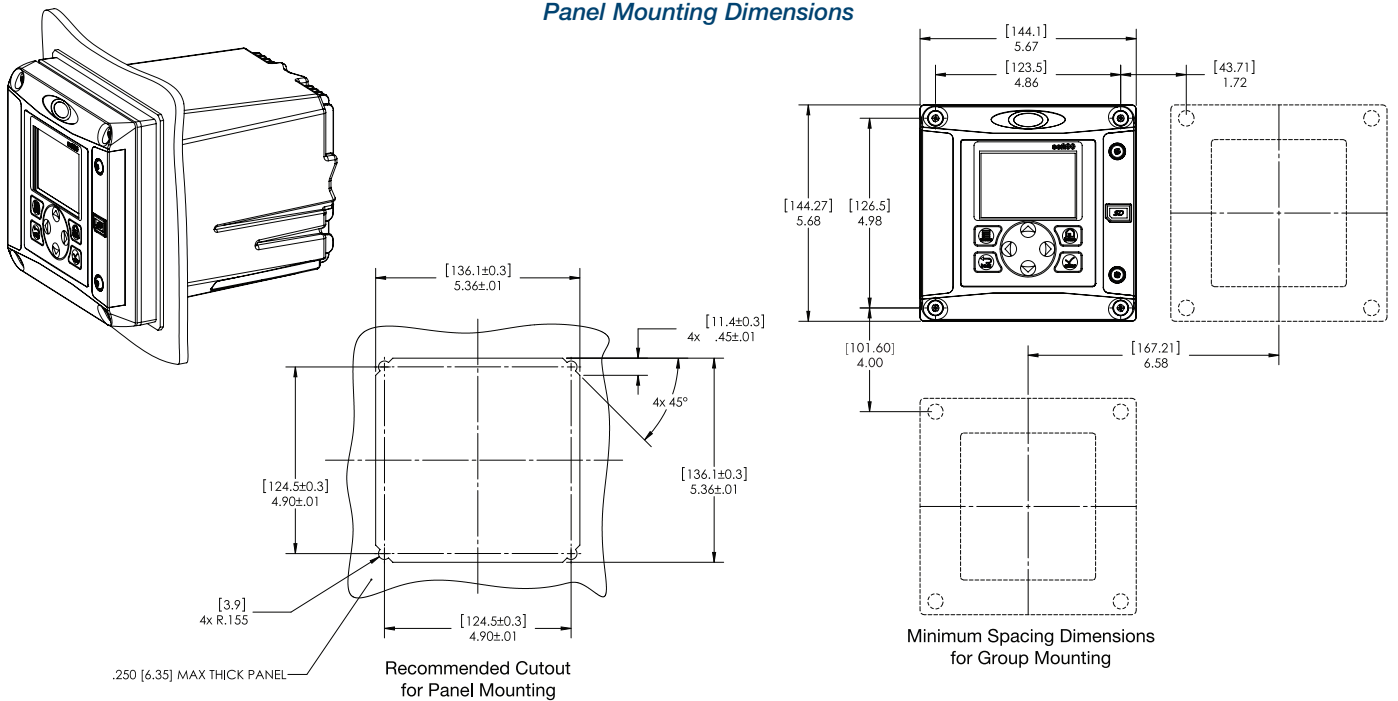

Top and Bottom Views

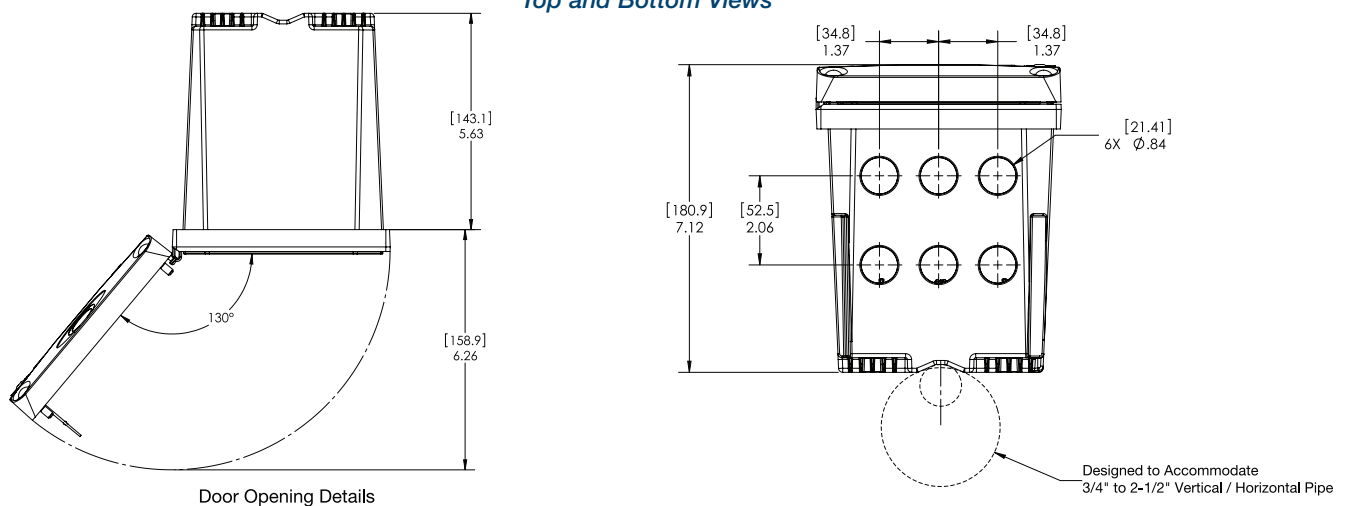

HACH LDO[®] Dissolved Oxygen Probe

Features and Benefits

Method of Detection

The HACH LDO sensor is coated with a luminescent material. Blue light from an LED is transmitted to the sensor surface. The blue light excites the luminescent material. As the material relaxes it emits red light. The time for the red light to be emitted is measured. Between the flashes of blue light, a red LED is flashed on the sensor and used as an internal reference.

Increased oxygen in the sample decreases the time it takes for the red light to be emitted. The time measurements correlate to the oxygen concentration.

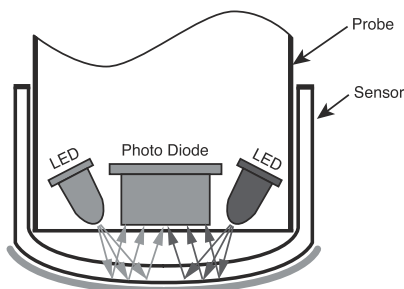

Accuracy and Speed

The sensor is unaffected by pH swings, hydrogen sulfide, wastewater chemicals, heavy metals, or organic build-up on the sensor. Warm-up time is unnecessary so the analyzer can start measuring within 30 seconds of when it's turned on.

Simple Installation and Maintenance

The HACH LDO probe can be installed with a choice of pole or ball-float mounting kits. The probe has only one inexpensive replacement part—the sensor cap that is simple to replace. The sensor cap is warranted for one year. The probe is warranted for three years.

An internal standard calibrates the instrument with every reading. Factory calibration and membrane replacement are unnecessary. Periodic wiping of the sensor with a wet rag is all that is required for continuous measurement.

Applications

- **Aeration Tanks**—Adequate dissolved oxygen levels in aeration basins are required for microorganisms to remain viable. The HACH LDO probe can be used with a variable frequency drive or PLC control system to control the amount of oxygen being injected into the tank.
- **Nitrification & Denitrification Tanks**
- **Anaerobic Digesters**
- **Aerobic Digesters**
- **NPDES Permit Monitoring**—Up and downstream from plant effluent and plant outfall.

DW = drinking water WW = wastewater municipal PW = pure water / power
IW = industrial water E = environmental C = collections FB = food and beverage



Break-through luminescent technology for dissolved oxygen. The HACH LDO[®] Dissolved Oxygen Probe continuously monitors DO with this revolutionary method of detection. It's virtually maintenance-free with no membranes to replace, no electrolyte solution to replenish, and no anode or cathode to clean or replace.

Full Featured “Plug and Play” sc100 Digital Controller

There's no complicated wiring or set up procedures with the Hach sc100 controller. Just plug in any Hach digital sensor and it's ready to use—it's “plug and play.”

One or two sensors—Use the sc100 Digital Controller to receive data from up to two Hach digital sensors in any combination.

Communications—Multiple alarm/control schemes are available using three relays and two PID control outputs. Communications use analog 4-20 mA and digital MODBUS[®]/RS485, MODBUS[®]/RS232 protocols. (Other digital protocols are available. Contact your Hach representative for details.) Every sc100 controller is equipped with wireless communication through an infrared port.

Data logger—A built-in data logger collects measurement data, calibration, verification points, and alarm history for up to 6 months.



Specifications*

Measuring Range

0 to 20.0 ppm,

0 to 20.0 mg/L,

0 to 200% saturation

Sensitivity

±0.5% of span

Accuracy

Measurement:

Below 1 ppm: ±0.1 ppm

Above 1 ppm: ±0.2 ppm

Temperature: ±0.2°C

Repeatability

±0.5% of span

Response Time at 20°C

To 90% in less than 40 seconds

To 95% in less than 60 seconds

Resolution

Below 10 ppm:

±0.01 ppm or mg/L, ±0.1% saturation

Above 10 ppm:

±0.1 ppm or mg/L, ±0.1% saturation

Operating Temperature

0 to 50°C (32 to 122°F)

Flow Rate

None required

Probe Immersion Depth and Pressure Limits

107 m (350 ft.), 1050 kPa (150 psi), maximum

Transmission Distance

100 m (328 ft.) maximum

1000 m (3280 ft.) maximum when used with a termination box

Sensor Cable (integral)

10 m (33 ft.) terminated with quick-disconnect plug

Wetted Materials

Probe: Foamed Noryl® and 316 stainless steel

Sensor: Polybutyl methacrylate

Dimensions

60 x 292 mm (2.4 x 11.5 in.)

Weight

1.4 kg (3 lb., 2 oz.)

Warranties

Probe: 3 Years

Sensor Cap: 1 Year

Noryl® is a registered trademark of General Electric Co.

*Specifications subject to change without notice.

Engineering Specifications

- The dissolved oxygen probe shall be a continuous-reading probe that utilizes luminescent sensor technology.
- The probe material shall be foamed Noryl® and 316 stainless steel. All parts of the probe shall be corrosion-resistant and fully-immersible.
- The sensor material shall be polybutyl methacrylate.
- The measurement range shall be 0.00 to 20.00 mg/L dissolved oxygen.
- The operation of the analyzer shall not be affected by H₂S, pH, K⁺, Na⁺, Mg²⁺, Ca²⁺, NH₄⁺, Al³⁺, Pb²⁺, Cd²⁺, Zn²⁺, Cr (total), Fe²⁺, Fe³⁺, Mn²⁺, Cu²⁺, Ni²⁺, Co²⁺, CN⁻, NO₃⁻, SO₄⁻², S⁻², PO₄⁺³, Cl⁻, anion active tensides, crude oils, or Cl₂⁻¹.
- The probe shall provide electrolyte-free operation without the requirements of sample conditioning.
- The probe shall be furnished with choice of pole or ball-float mount kit.
- The sensor cap shall be warranted for one full year against defects in material and workmanship.
- The probe shall be warranted for three full years against defects in material and workmanship.
- The analyzer shall be HACH LDO® Probe for dissolved oxygen measurement, manufactured by Hach Company.

Dimensions

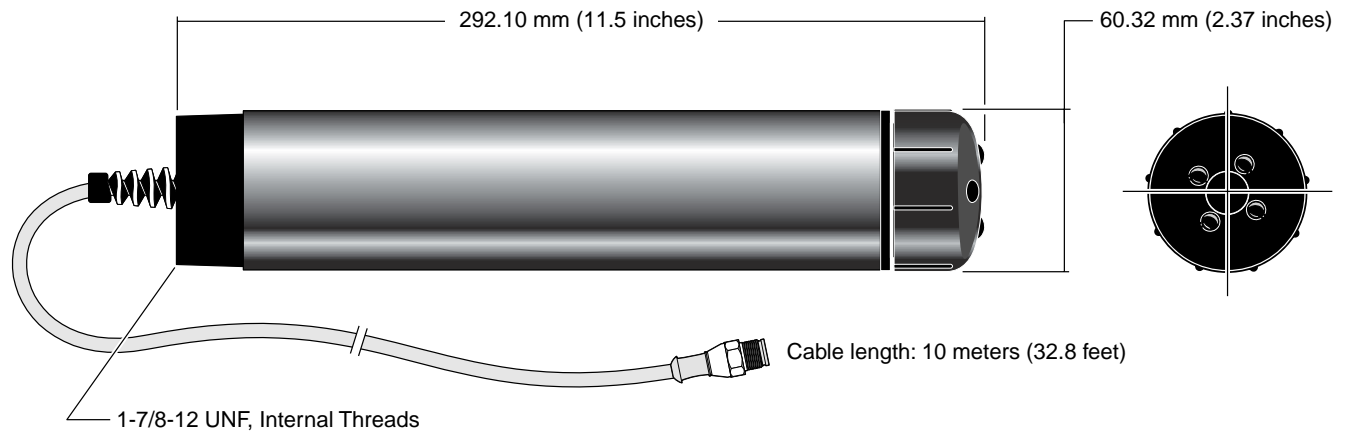

Installation Examples

The HACH LDO[®] Probe can be mounted using the optional Pole Mount Kit (P/N 57944-00) or Ball Float Mount Kit (P/N 57943-00).

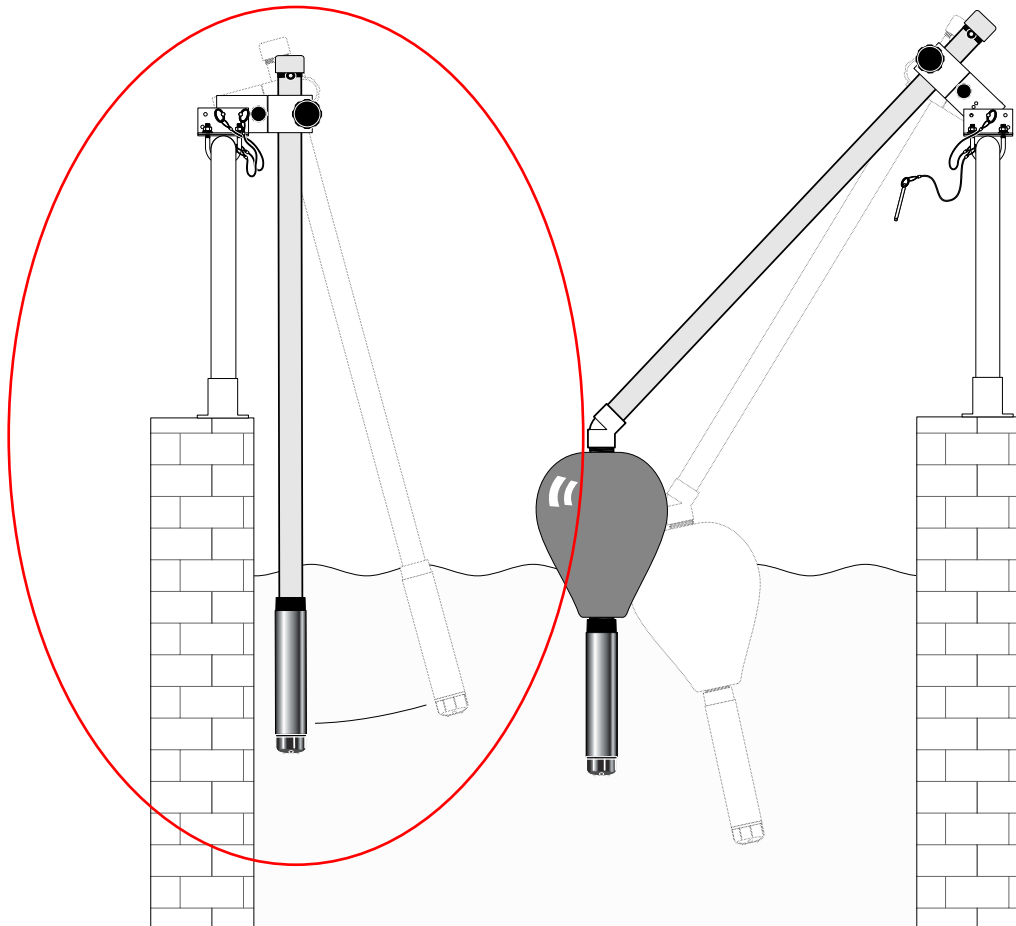

Differential pH and ORP Sensors

pH/ORP



Hach Digital pH/ORP sensors are available in convertible (PEEK® or Rytan®), insertion, and sanitary body styles. Three electrodes are used in these sensors to increase measurement accuracy and eliminate sensor ground loops.

Features and Benefits

Differential Electrode Measurement Technique

This field-proven technique uses three electrodes instead of the two normally used in conventional pH sensors. Process and reference electrodes measure the pH differentially with respect to a third ground electrode. The end result is unsurpassed measurement accuracy, reduced reference junction potential, and elimination of sensor ground loops. These sensors provide greater reliability, resulting in less downtime and maintenance.

Patented Technology

The former GLI, now a Hach Company brand, invented the Differential Electrode Technique for pH measurement in 1970. The pH^{DM} sensor series (U.S. Patent Number 6395158B1, dated May 28, 2002) takes this field-proven technology to a new level.

Replaceable Salt Bridge/Protector

The unique, replaceable salt bridge holds an extraordinary volume of buffer to extend the working life of the sensor by protecting the reference electrode from harsh process conditions. The salt bridge simply threads onto the end of the sensor if replacement is needed.

Built-in Encapsulated Preamp

Encapsulated construction protects the sensor's built-in preamp from moisture and humidity, ensuring reliable sensor operation. The preamp in the pH^{DM} analog sensor produces a strong signal, enabling the sensor to be located up to 1000 m (3280 ft.) from the analyzer.

Durable Body Materials

Both the digital and analog pH and ORP differential sensors feature a durable PEEK® body for chemical compatibility

with most process solutions. For less aggressive solutions, Hach offers a Rytan® sensor in a convertible style for pH and ORP measurement. A sensor with a stainless steel body is available for immersion applications.

Digital Electronics Modules

Sensors are available with integral digital electronics or with a gateway module for high temperature (above 70°C) applications.

Versatile Mounting Styles

Sensors are available in four mounting styles—convertible, insertion, immersion, and sanitary. Please turn to page 5 for more information.

Full-Featured “Plug and Play” Hach sc Digital Controllers

There are no complicated wiring or set up procedures with any Hach sc controller. Just plug in any combination of Hach digital sensors and it's ready to use—it's “plug and play.”

One or multiple sensors—The sc controller family allows you to receive data from up to eight Hach digital sensors in any combination using a single controller.

Communications—Multiple alarm/control schemes are available using the relays and PID control outputs. Available communications include analog 4–20 mA, digital MODBUS® (RS485 and RS232) or Profibus DP protocols. (Other digital protocols are available. Contact your Hach representative for details.)

Data logger—A built-in data logger collects measurement data, calibration, verification points, and alarm history.

DW = drinking water WW = wastewater municipal PW = pure water / power
IW = industrial water E = environmental C = collections FB = food and beverage



Be Right™

DW

WW

PW

IW

Specifications*

pH Sensors

Most pH applications fall in the 2.5 to 12.5 pH range. A Hach pHD sc Differential pH sensor with the wide-range glass process electrode performs exceptionally well in this range. Some industrial applications require accurate measurement and control below 2 or above 12 pH. In these special cases, please contact Hach Technical Support for further details.

Measuring Range

-2 to 14 pH

Sensitivity

± 0.01 pH

Stability

0.03 pH per 24 hours, non-cumulative

Operating Temperature

Digital Sensor: -5 to 70°C (23 to 158°F)

Analog Sensor with Digital Gateway: -5 to 105°C (23 to 221°F)

Immersion Sensor: 0 to 50°C (32 to 122°F)

Flow Rate

3 m (10 ft.) per second, maximum

Sensor Pressure/Temperature Limits

Digital: 6.9 bar at 70°C (100 psi at 158°F)

Analog: 6.9 bar at 105°C (100 psi at 221°F)

Built-in Temperature Element

NTC 300 ohm thermistor for automatic temperature compensation and analyzer temperature readout

Transmission Distance

100 m (328 ft.), maximum

1000 m (3280 ft.), maximum when used with a termination box

Sensor Cable (integral)

4 conductor cable with one shield and polyurethane jacket; rated to 105°C (221°F); 10 m (33 ft.) standard length

Wetted Materials

PEEK® or Ryton® (PVDF), salt bridge of matching material with Kynar® junction, glass process electrode, titanium ground electrode, and Viton® O-ring seals

(pH sensor with optional HF-resistant glass process electrode has 316 stainless steel ground electrode, and perfluoroelastomer wetted O-rings; consult factory for other available wetted O-ring materials)

ORP (Redox) Sensors

For best ORP measuring results in solutions containing zinc, cyanide, cadmium or nickel, Hach recommends using the pHD sc ORP sensor equipped with an optional gold electrode.

Measuring Range

-1500 to +1500 mV

Sensitivity

± 0.5 mV

Stability

2 mV per 24 hours, non-cumulative

Operating Temperature

Digital Sensor: -5 to 70°C (23 to 158°F)

Analog Sensor with Digital Gateway: -5 to 105°C (23 to 221°F)

Immersion Sensor: 0 to 50°C (32 to 122°F)

Flow Rate

3 m (10 ft.) per second, maximum

Sensor Pressure/Temperature Limits

Digital: 6.9 bar at 70°C (100 psi at 158°F)

Analog: 6.9 bar at 105°C (100 psi at 221°F)

Built-in Temperature Element

NTC 300 ohm thermistor for analyzer temperature readout only—no automatic temperature compensation necessary for ORP measurement

Transmission Distance

100 m (328 ft.), maximum

1000 m (3280 ft.), maximum when used with a termination box

Sensor Cable (integral)

4 conductor cable with one shield and polyurethane jacket; rated to 105°C (221°F); 10 m (33 ft.) standard length

Wetted Materials

PEEK® or Ryton® (PVDF), salt bridge of matching material with Kynar® junction, glass and platinum (or plastic and gold) process electrode, titanium ground electrode, and Viton® O-ring seals

*Specifications subject to change without notice.

Engineering Specifications

PEEK® Sensor

1. The pH or ORP sensor shall be of Differential Electrode Technique design using two measuring electrodes to compare the process value to a stable internal reference standard buffer solution. The standard electrode shall have non-flowing and fouling-resistant characteristics.
2. The sensor shall have a hex-shaped body to facilitate mounting, and shall be constructed of PEEK® material for exceptional chemical resistance and mechanical strength. This material shall enable the sensor to be installed in metal fittings without leakage usually caused by heating and cooling cycles when dissimilar materials are threaded together.
3. The sensor shall have a:
 - a) Convertible body style featuring 1-inch NPT threads on both ends to mount into a standard 1-inch pipe tee, into a Hach adapter pipe for union mounting with a standard 1-1/2 inch tee, or onto the end of a pipe for immersion into a vessel.
 - b) Insertion body style featuring 1-inch NPT threads only on the cable end to mount into a Hach ball valve hardware assembly, enabling the sensor to be inserted into or retracted from the process without stopping the process flow.
 - c) Sanitary body style featuring an integral 2-inch flange to mount into a Hach 2-inch sanitary tee. The sanitary body style sensor shall include a special cap and EDPM compound gasket for use with the Hach sanitary hardware.
4. The built-in electronics of the sensor shall be completely encapsulated for protection from moisture and humidity.
5. The sensor shall have a built-in preamplifier to enable the signal to be transmitted up to 100 m (328 ft.) with standard cabling and up to 1000 m (3280 ft.) with a termination box.
6. The sensor signal shall have an integral temperature sensor. The pH sensor shall automatically compensate measured values for changes in process temperature.
7. The ORP sensor shall include a titanium ground electrode (standard) to eliminate ground loop currents in the measuring electrodes.
8. The sensor shall be Hach Company Model pHD sc or pHD for pH or ORP measurement.

Ryton® Sensor

1. The pH or ORP sensor shall be of Differential Electrode Technique design using two measuring electrodes to compare the process value to a stable internal reference standard buffer solution. The standard electrode shall have non-flowing and fouling-resistant characteristics.
2. The sensor shall have a hex-shaped body to facilitate mounting, and shall be constructed of Ryton® material for exceptional chemical resistance and mechanical strength. This material shall enable the sensor to be installed in metal fittings without leakage usually caused by heating and cooling cycles when dissimilar materials are threaded together.
3. The sensor shall have a convertible body style featuring 1-inch NPT threads on both ends to mount into a standard 1-inch pipe tee, into a Hach adapter pipe for union mounting with a standard 1-1/2 inch tee, or onto the end of a pipe for immersion into a vessel.
4. The built-in electronics of the sensor shall be completely encapsulated for protection from moisture and humidity.
5. The sensor shall have a built-in preamplifier to enable the signal to be transmitted up to 100 m (328 ft.) with standard cabling and up to 1000 m (3280 ft.) with a termination box.
6. The sensor signal shall have an integral temperature sensor. The pH sensor shall automatically compensate measured values for changes in process temperature.
7. The ORP sensor shall include a titanium ground electrode (standard) to eliminate ground loop currents in the measuring electrodes.
8. The sensor shall be Hach Company Model pHD sc or pHD for pH or ORP measurement.

Stainless Steel Sensor

1. The pH or ORP sensor shall be of differential electrode technique design using two measuring electrodes to compare the process value to a stable internal reference standard buffer solution. The standard electrode shall have non-flowing and fouling-resistant characteristics.
2. The sensor shall be capable of chain mounting for immersion applications, and shall be constructed of 316 stainless steel.
3. The built-in electronics of the sensor shall be completely encapsulated for protection from moisture and humidity.
4. The sensor shall have a built-in preamplifier to enable the signal to be transmitted up to 100 m (328 ft.) with standard cabling and up to 1000 m (3280 ft.) with a termination box.
5. The sensor signal shall have an integral temperature sensor to automatically compensate measured values for changes in process temperature.
6. The sensor shall include a titanium ground electrode (standard) to eliminate ground loop currents in the measuring electrodes.
7. The sensor shall be Hach Company Model pHD sc or pHD for pH or ORP measurement.

Dimensions

Convertible Style

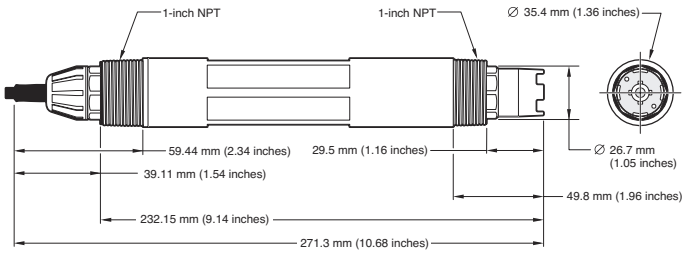

Insertion Style

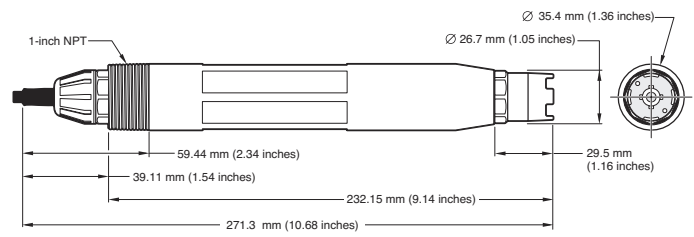

Sanitary Style

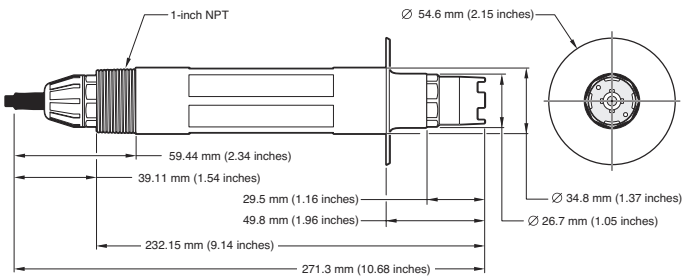

Immersion Style

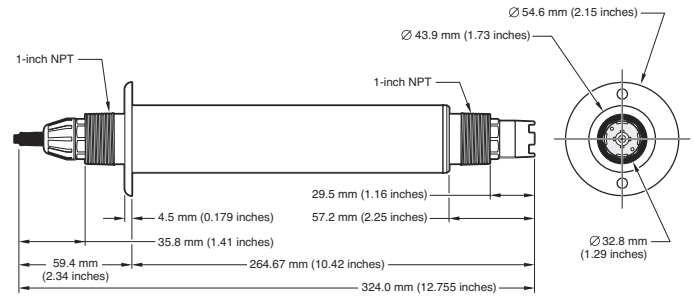

Analog Convertible Style

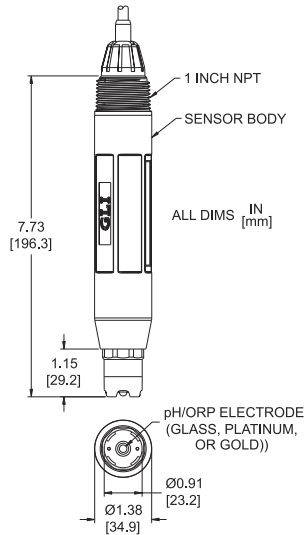

Analog Insertion Style

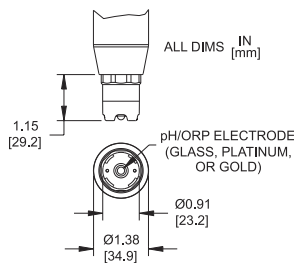

Analog Sanitary Style

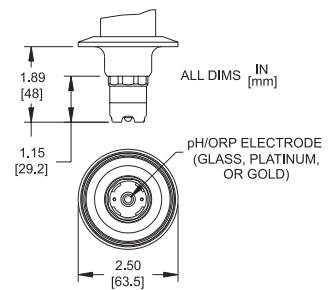

Ordering Information *continued*

Mounting Hardware for pH/DO sc Differential Sensors

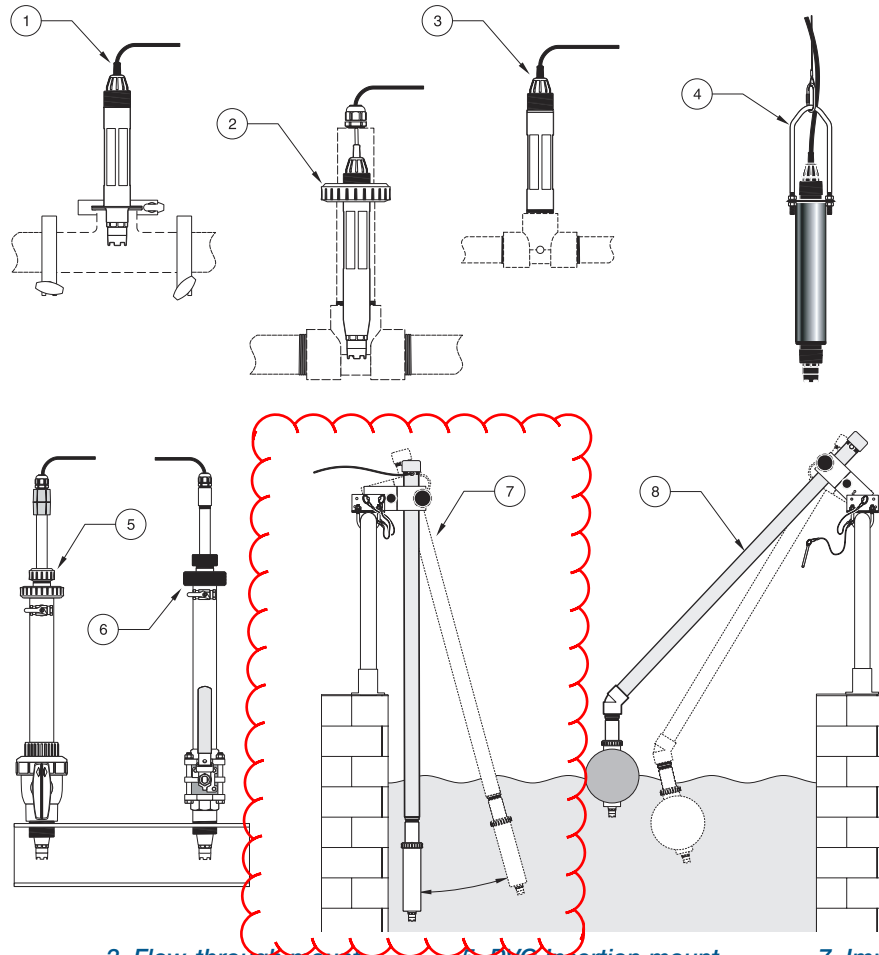

1. Sanitary mount
2. Union mount

3. Flow-through mount
4. Hanging stainless steel sensor with the bail

5. PVC Insertion mount
6. Stainless steel insertion mount

7. Immersion mount
8. Immersion mount, ball float

Sanitary Mount

MH018S8SZ 316 SS
Includes 2-inch sanitary tee and heavy-duty clamp. Special cap and EPDM compound gasket are supplied with sensor but can be separately ordered.

Union Mount

6131300 CPVC
6131400 316 SS
Includes standard 1-1/2 inch tee, special union pipe with adapter, sealing hub, and lock ring in respective material, and Viton® O-ring.

Flow-through Mount

MH334N4NZ CPVC
MH314N4MZ 316 SS
Includes a standard 1-inch tee in respective material.

Insertion Mount

<i>Digital</i>		<i>Analog</i>	
5646300	CPVC	5646400	CPVC
5646350	316 SS	5646450	316 SS

Includes a 1-1/2 inch ball valve in respective material, 1-1/2 inch NPT close nipple, sensor adapter with two Viton® O-rings and wiper, extension pipe, pipe adapter, back tube, and lock ring.

Immersion Mount

Standard Hardware

<i>Digital</i>		<i>Analog</i>	
6136400	CPVC	MH434A00B	CPVC
6136500	316 SS	MH414A00B	316 SS

Includes 1-inch diameter by 4 ft. long pipe and 1-inch x 1-inch NPT coupling in respective material. (Pipe-mount junction box with terminal strip included in analog hardware.)

Handrail Hardware

→ **MH236B00Z** CPVC
Includes 1-1/2 inch diameter by 7.5 ft. long CPVC pipe, and a unique swivel/pivot/ pipe clamp assembly.

Chain Mount Hardware

2881900 316 ss
Includes stainless steel bail, nuts, and washers. Does not include chain. To be used with stainless steel immersion sensor only.

Ball Float Hardware

6131000 CPVC
Includes 1-1/2 inch diameter by 7.5 ft. long CPVC pipe, ball float assembly, and a unique swivel/pivot/ pipe clamp assembly.

NOTE

Contact Hach Technical Support or your Hach representative for information about retro fit hardware for existing installations.

NOTES:
DIMENSIONS ARE IN INCHES [CENTIMETERS].

REVISION		
REV	DESCRIPTION	APPROVED
A		

D

D

[13.21]
5.20
CENTER OF HAND RAIL TO
CENTER OF POLE

[251.46]
99.00

POLE & PROBE SWIVEL INTO
PROCESS OR ONTO SERVICE
SUPPORT BRACKET

1 1/2" SCHEDULE 80 PVC PIPE

PVC SUPPORT
FOR SERVICING
PROBE

PVC ADAPTER TO
CONNECT TO PROBE

STAINLESS STEEL
BRACKET & U-BOLT
CUSTOMER HAND RAIL REF.

C

C

B

B

PVC END CAP

PHENOLIC KNOB (2X)

PIPE IS ADJUSTABLE IN
CLAMP FOR FLUID LEVEL

[13.21]
5.20
REF

STAINLESS STEEL BRACKET & U-BOLTS

PVC SWIVEL & CLAMP

NOTICE--HACH COMPANY CLAIMS PROPRIETARY RIGHTS IN THE INFORMATION DISCLOSED ON THIS DRAWING. IT IS ISSUED IN CONFIDENCE FOR ENGINEERING INFORMATION ONLY AND MAY NOT, IN WHOLE OR IN PART, BE USED TO MANUFACTURE ANYTHING, WHETHER OR NOT SHOWN HEREON, REPRODUCED OR DISCLOSED TO ANYONE WITHOUT DIRECT PERMISSION FROM HACH COMPANY.

MATERIAL

UNLESS OTHERWISE SPECIFIED:

DIMENSIONS ARE IN INCHES
TOLERANCES:
.X = ±
.XX = ±
.XXX = ±
ANGLES = ±

INTERPRET GEOMETRIC
TOLERANCING PER:
ANSI Y14.5M 1994

DO NOT SCALE DRAWING

	NAME	DATE
DRAWN	TCS	04/14/11
ENGINEER	TCS	04/14/11

THIRD ANGLE PROJECTION

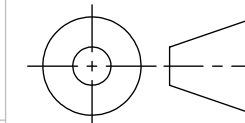

HACH COMPANY
5600 LINDBERGH DR.
LOVELAND, CO. 80539

TITLE: **TRANSMITTAL,
UNIVERSAL, HANDRAIL MOUNT**

SIZE DWG. NO. REV

B UNIVERSAL HANDRAIL MOUNT ASSEMBLY **A**

SCALE: 1:10 WEIGHT: SHEET 1 OF 1

A

A

8

7

6

5

4

3

2

1

Data sheet

Wilo-EMU TR 221.49-4/8V

Design / Direction of rotation

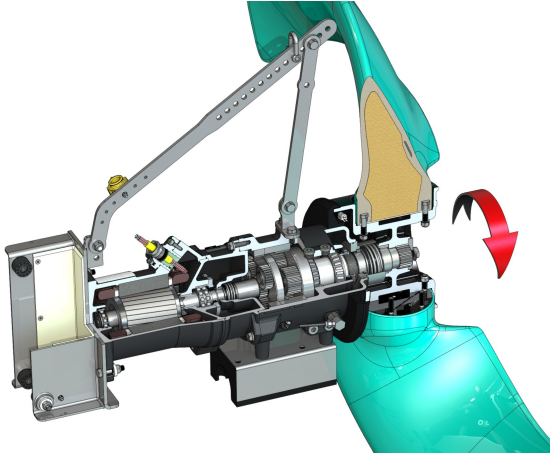

Technical data	
Unit	
Power Consumed $P_{1,1}$	4.3 hp
Max. thrust F	540 lb _f
Weight of unit m	392.4 lbs
Max. weight* m	440.9 lbs
Protection class	IP 68
Explosion protection	FM, CSA
Ex classification FM	CLASS I, DIV. 1, GROUPS C, D; CLASS II, DIV. 1, GROUPS E, F, G; CLASS III

* = maximum weight including accessories

Propeller	
Propeller model	2-blade propeller with self-cleaning hub; backward-curved as a result clogging- and entwining-free
Nominal propeller diameter	82.7 in
Propeller speed n	49 rpm
Transmission ratio	34.658

Fill quantities and types	
Filling prechamber	CLP transmission oil, ISO VG 220
Filling volume prechamber V	0.3 gal (US)
Filling gear chamber	CLP transmission oil, ISO VG 220
Fill quantity gear chamber V	0.2 gal (US)
Filling sealing chamber	White oil
Fill level sealing chamber V	0.3 gal (US)

Motor data	
Type of motor	T 17-4/8V (Ex)
Motor type	Submersible motor according to DIN/VDE 0530 (IEC 34)
Power connection	3~460 V, 60 Hz
Full load amps I_N	6.7 A
Starting current - direct I_A	33 A
Starting current - star-delta I_A	11 A
Maximum power consumption P_1	6.2 hp
Rated motor power P_2	4.4 hp
Rated speed n	1680 rpm
Motor Efficiency Level	-
Efficiency η_M	72.0 %
Power factor $\cos \varphi$	0.86
Fluid temperature T	37 ... 104 °F
Max. submersion	66 ft
Insulation class	H
Max. switching frequency t	15 /h
min. switching break t	3 min
Starting torque M	42 Nm
Moment of inertia	0.0073 kg/m ²
Motor bearings	1 grooved ball bearing, 1 two-row inclined ball bearing

Materials	
Motor housing	ASTM A48 Class 35/40B
Motor shaft	1.4021
Gear housing	ASTM A48 Class 35/40B
Planetary gear	1.7131
Hollow gear	1.5216
Sun gear	1.7131
Output shaft	1.4462
Static seal	FPM
Mechanical seal	SiC/SiC
Seal, gear chamber/prechamber	FPM
Seal, gear/sealing chamber	SiC/SiC
Sealing on motor side	FPM
Propeller	GfK Vinylester

Gear	
Gear construction type	m 2.0 as per DIN 780/P10 (ISO 54); Sun and planetary gears case hardened and sanded, internal gear butt-jointed
Gear bearings	Six needle roller bearing (planetary), two tapered roller bearings (output shaft adjustable type), gearing permanently fixed
Service life L_{h10}	> 100000 operating hours, ISO 281

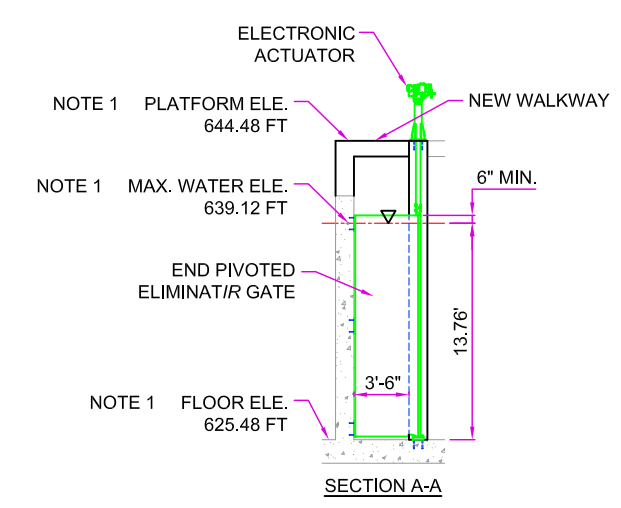
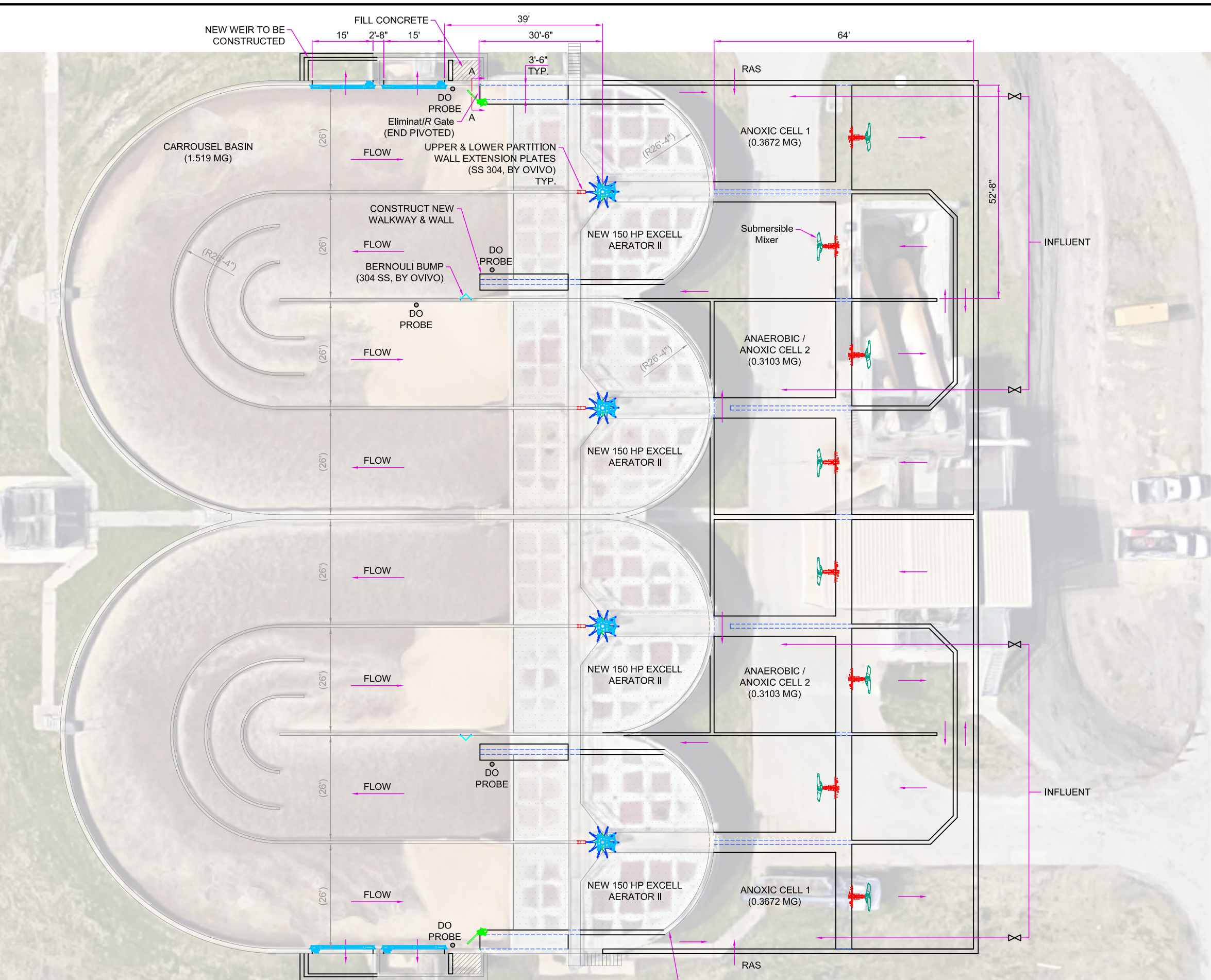

NOTE:
1. ELEVATIONS TO BE VARIFIED

AEROBIC SRT (Days)	MLSS (mg/l)	PER TRAIN		
		Vaer (MG)	Vanx (MG)	SWD (ft.)
11	4,000	1.519	0.675	13.76

NOTE : Plant may be operated at 9 days aerobic SRT (listed in specification) and at lower MLSS if desired.

PFLUGERVILLE CENTRAL WWTP, TX
EXISTING BASIN LAYOUT
SWD = 13.76 FT

EXISTING WALL
MUST BE MODIFIED
TO ACCOMMODATE
NEW IR CHANNEL

D <small>©COPYRIGHT 2010 GLV ALL RIGHTS RESERVED -REV E</small>		 THIRD ANGLE PROJECTION		 Bringing water to life	
<small>THIS DRAWING CONTAINS CONFIDENTIAL PROPRIETARY INFORMATION OF OVIVO, AND ITS AFFILIATES, AND IS NOT TO BE DISCLOSED NOR TO BE USED EXCEPT FOR EVALUATING PROPOSALS OF OVIVO OR INSTALLING, OPERATING OR MAINTAINING OVIVO EQUIPMENT, UNLESS OTHERWISE AUTHORIZED IN WRITING BY OVIVO.</small>					
REF. FROM:	-	DO NOT SCALE PRINTS			
DATE (mm/dd/yyyy)	11/21/2018	UNCONTROLLED COPY IF PRINTED			
DRAWN	JSM	ORIGINAL S.O.		DWG. NO.	-
CHECK'D	MAC			SHEET	1 OF 1

INITIAL RELEASE	REVISION	EN/ECO	BY	CHECK'D	DATE

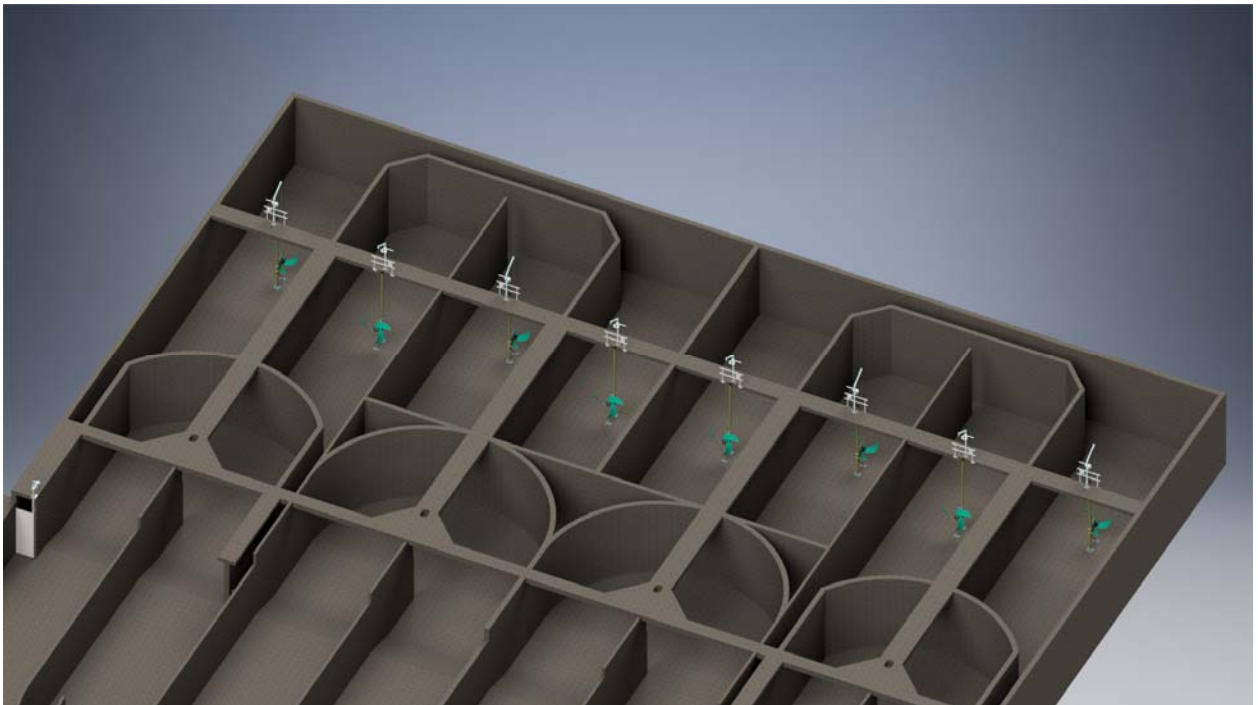
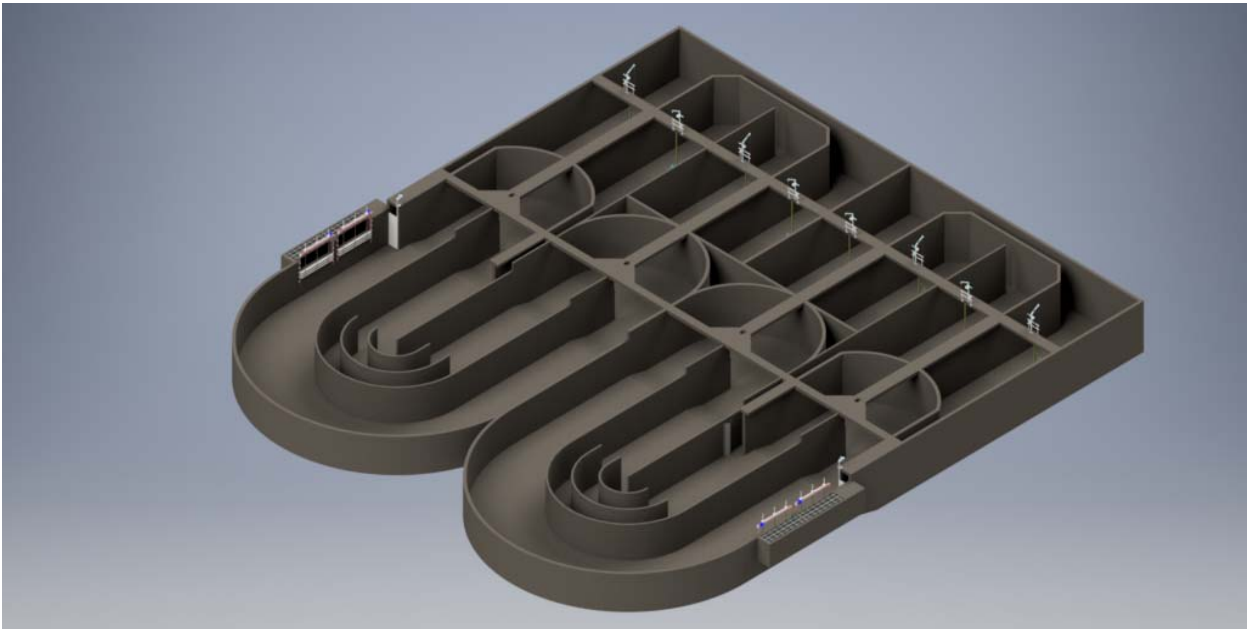

Basin Renderings – Basin overview (Top) and Anoxic/Anaerobic basin view (Bottom)

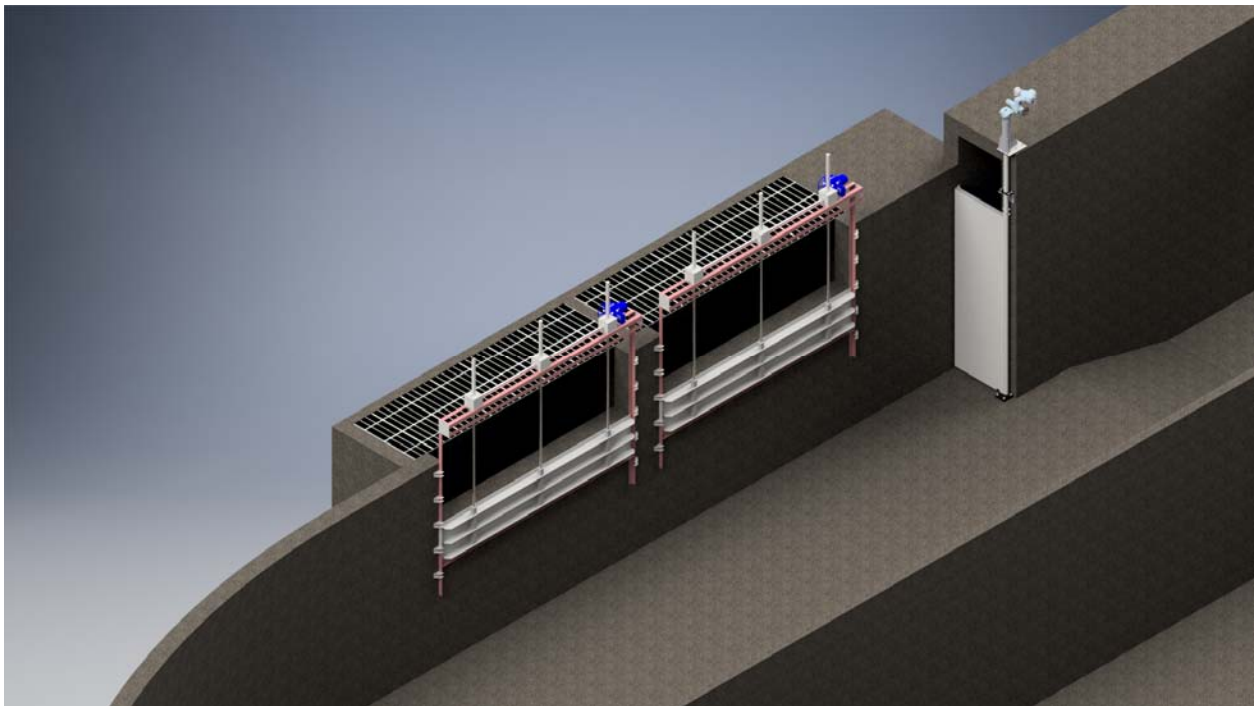
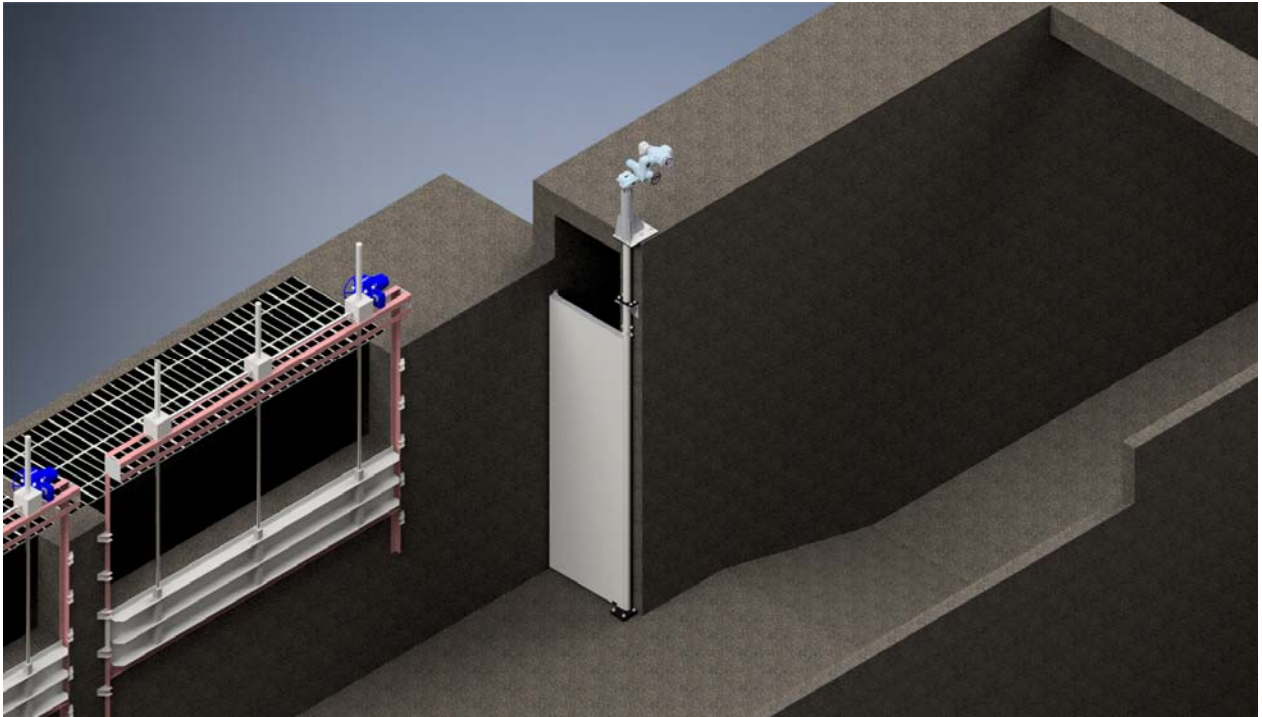

Basin Renderings – EliminatIR Gate view (Top) and New Weir Gates (Bottom)

Vertical AC Motors

1HP - 700 HP

140T - 5010 FRAMES

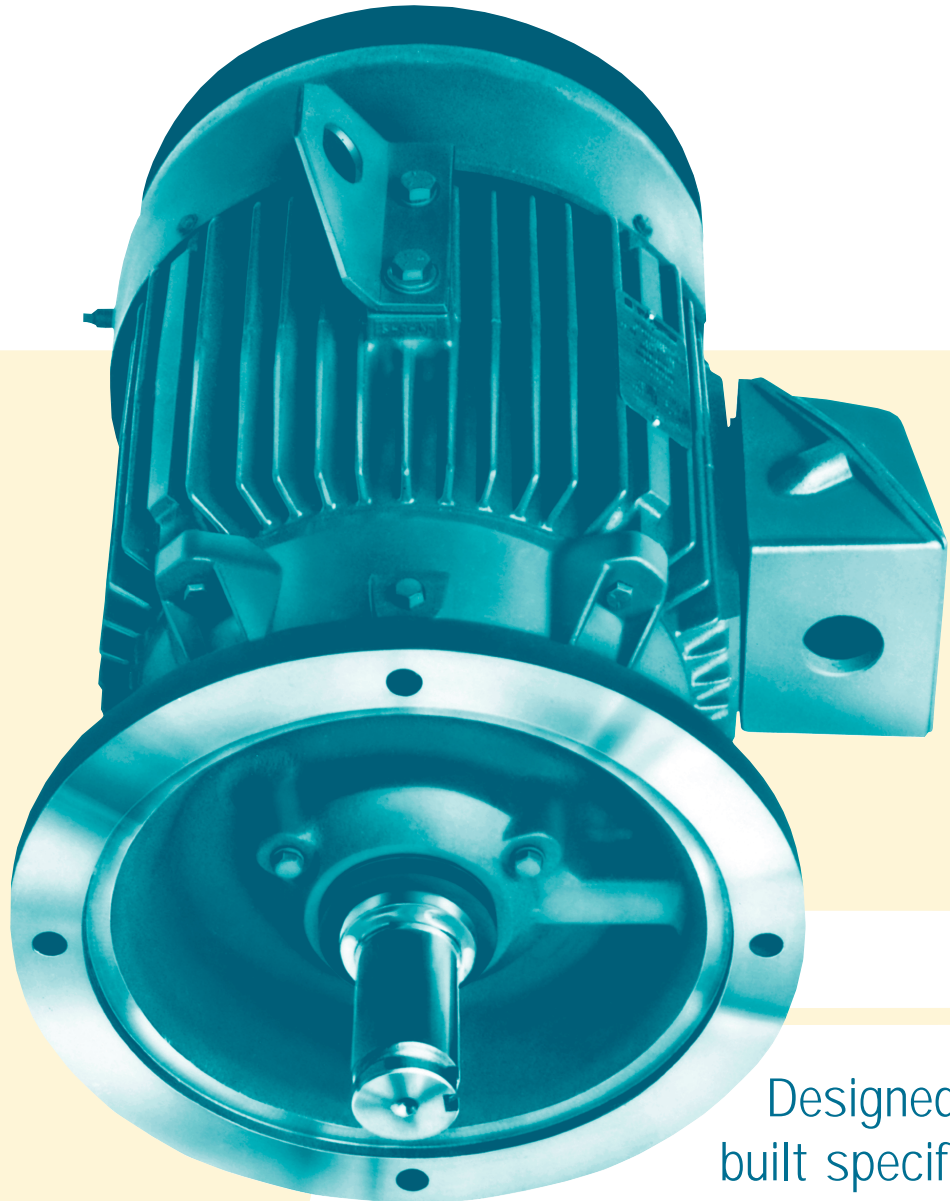

Designed and
built specifically
for vertical service!

Paint Procedures for Electric Motors

The following outlines the general procedures used in painting motors produced at the Reliance Electric Athens Plant.

Cast Iron Motors & Parts

A. Preparation & Painting

1. Castings are cleaned at the producing foundries using Wheelabrator-type machinery to obtain “commercial blasted finish.” (Equivalent to SSPC-SP6)
2. The foundries apply the Reliance specified primer by dip coating or spraying to obtain a dry film thickness of 2 mils minimum. After drying, the castings are shipped to the Reliance motor plant.
3. At the motor plant castings are machined, chemically washed, and assembled into the motors. Prior to final spray painting, the motors are cleaned to remove loose chips, dust, oil, grease, and other matter.
4. Finish paint is applied using conventional spray equipment. Coating is to provide an additional 1-2 mils minimum of finish coat.
5. Finished units are air dried prior to packaging. Damaged areas are touched up by spot cleaning and spraying.

B. Paint System

1. Epoxy modified alkyd primer with rust inhibitors.
Color: Blue-Green.
2. Two component polyamide epoxy finish with rust inhibitors.
Color: Blue-Green.



C. Paints

<u>Function</u>	<u>Primer</u>	<u>Finish</u>
TYPE	HIGH SOLIDS EPOXY MOD. ALKYD	POLYAMIDE EPOXY
RELIANCE SPEC #	4824-3-AKW	4824-3-APX
APPLICATION	DIP OR SPRAY	SPRAY
COLOR	BLUE-GREEN	BLUE-GREEN
SOLVENT/ THINNER	N/A	WATER
COMPONENTS	ONE	TWO 10-1 MIX RATIO
POT LIFE	N/A	8 HRS
DRY TIME TO TOUCH	25 MINS	15 MINS
THEORETICAL COVERAGE AT MIL	816 SQ FT/GAL	669 SQ FT/GAL
VOLUME	51.0%	41.8%
VOC	3.5 LB/GAL	1.8 LB/GAL

NOTE: Both primer and finish coatings have USDA acceptance for incidental food contact.





FLENDER ZAHNRADGETRIEBE

**Belüfterantriebe
Aerator Drives
Entraînements d'aérateurs**

FLENDER

FLENDER

Flender's coating for corrosion prevention in wastewater applications is defined in the factory as level G5.

Corrosion Prevention G5:	Highly chemical-resistant coating, consisting of the following:
External Preservative Tectyl 280 EH or Tectyl 846 K19	Long term wax-based preservative agent, resistant to sea water and tropical conditions (soluble with CH compounds) Applied at approximately 50 µm to all shaft ends and bright machined surfaces. Suitable protection for 24 months.
Internal Preservative Castrol Alpha SP 220S	Light oil film coating for all internal parts. Suitable protection for 24 months.
First Primer: P22, RAL 8050	Prior to priming the surfaces must be pre-treated to remove all preservatives. The primer shall be resistant to mineral oils and PG and PAO-based synthetic oils, sufficiently weatherproof, temperature-resistant up to 120° C (up to 140° C for short periods), bonding agent: can generally be painted over. Color – anthracene brown applied at approximately 30 µm.
Second Primer: Metal Primer 2091 Rapid, RAL 7035	Bonding agent Color – pale grey applied at maximum of 20 µm.
Finishing Coat: PU Thick Coat 5240 HC Mixture ratio 5:1 RAL 5015	Highly chemical resistant to increase the resistance Color – Flender sky blue Two thick coats, each applied at 80 to 100 µm.

FABRICATED STEEL



PRODUCT PROFILE

GENERIC DESCRIPTION	Polyamide Epoxy
COMMON USAGE	Low temperature-cure, corrosion-resistant coating for protection against abrasion, immersion and mild chemical contact. Fast recoat at 75°F (24°C).
COLORS	Refer to Tnemec Color Guide. Note: Epoxies chalk with extended exposure to sunlight. Lack of ventilation, incomplete mixing, miscatalyzation or the use of heaters that emit carbon dioxide and carbon monoxide during application and initial stages of curing may cause yellowing to occur.
FINISH	Satin
PERFORMANCE CRITERIA	Extensive test data available. Contact your Tnemec representative for specific test results.

COATING SYSTEM

PRIMERS	Steel: Self-priming or Series 20, FC20, 37H, 66, N69, N69F, 90, 160, 530 Galvanized Steel and Non-Ferrous Metal: Self-priming or Series 66, N69 Concrete: Self-priming or 54-660, 130, 201, 214 CMU: 54-562, 54-660, 130, 216, 218 Drywall: 51-792 for dry interior environments
TOPCOATS	46H-413, 66, N69, 73, 84, 104, 113, 114, 161, 175, 262, 265, 290, 291, 1074, 1075. Refer to COLORS on applicable topcoat data sheets for additional information.

SURFACE PREPARATION

STEEL	Immersion Service: SSPC-SP10 Near-White Blast Cleaning Non-Immersion Service: SSPC-SP6 Commercial Blast Cleaning
PRIMED SURFACES	Immersion Service: Scarify the Series 161 prime coat surface by abrasive-blasting with a fine abrasive before topcoating if: (a) the Series 161 has been exterior exposed for 60 days or longer and 46H-413, 66, N69 or 161 is the specified topcoat; (b) the Series 161 prime coat has been exterior exposed for 14 days or longer and Series 104 is the specified topcoat; (c) the Series 161 prime coat has been exterior exposed for 7 days or longer and Series 262 or 265 is the specified topcoat.
GALVANIZED STEEL & NON-FERROUS METAL	Surface preparation recommendations will vary depending on substrate and exposure conditions. Contact your Tnemec representative or Tnemec Technical Services.
CAST/DUCTILE IRON	Contact your Tnemec representative or Tnemec Technical Services.
CONCRETE	Allow new concrete to cure 28 days. For optimum results and/or immersion service, abrasive blast referencing SSPC-SP13/NACE 6 Surface Preparation of Concrete and Tnemec's Surface Preparation and Application Guide.
CMU	Allow mortar to cure for 28 days. Level protrusions and mortar spatter.
PAINTED SURFACES	Non-Immersion Service: Ask your Tnemec representative for specific recommendations.
ALL SURFACES	Must be clean, dry and free of oil, grease and other contaminants.

TECHNICAL DATA

VOLUME SOLIDS*	58.0 ± 2.0% (mixed)				
RECOMMENDED DFT	2.0 to 6.0 mils (50 to 150 microns) per coat. Note: Number of coats and thickness requirements will vary with substrate, application method and exposure. Contact your Tnemec representative.				
CURING TIME	Temperature	To Touch	To Handle	To Recoat	Immersion
	75°F (24°C)	1 hour	2-3 hours	3-4 hours	3 days
	65°F (18°C)	2 hours	4-5 hours	5-6 hours	4-5 days
	55°F (13°C)	3-4 hours	6-8 hours	10-12 hours	6-7 days
	45°F (7°C)	6-7 hours	12-14 hours	16-18 hours	9-10 days
	35°F (2°C)	8-10 hours	16-18 hours	20-22 hours	12-14 days
	Curing time varies with surface temperature, air movement, humidity and film thickness.				
VOLATILE ORGANIC COMPOUNDS*	Unthinned	Thinned 5%		Thinned 10%	
	2.92 lbs/gallon (349 grams/litre)	3.11 lbs/gallon (372 grams/litre)		3.28 lbs/gallon (393 grams/litre)	
THEORETICAL COVERAGE*	930 mil sq ft/gal (22.8 m ² /L at 25 microns). See APPLICATION for coverage rates.				
NUMBER OF COMPONENTS	Two: Part A and Part B				

TECHNICAL DATA continued

PACKAGING	5 gallon (18.9L) pails and 1 gallon (3.79L) cans—Order in multiples of 2.		
NET WEIGHT PER GALLON*	12.50 ± 0.25 lbs (5.67 ± .11 kg)		
STORAGE TEMPERATURE	Minimum 20°F (-7°C)	Maximum 110°F (43°C)	
TEMPERATURE RESISTANCE	(Dry) Continuous 250°F (121°C)	Intermittent 275°F (135°C)	
SHELF LIFE	Part A: 24 months; Part B: 12 months at recommended storage temperature.		
FLASH POINT - SETA	Part A: 82°F (28°C)	Part B: 64°F (18°C)	
HEALTH & SAFETY	Paint products contain chemical ingredients which are considered hazardous. Read container label warning and Material Safety Data Sheet for important health and safety information prior to the use of this product. Keep out of the reach of children.		

APPLICATION

COVERAGE RATES*

	Dry Mils (Microns)	Wet Mils (Microns)	Sq Ft/Gal (m ² /Gal)
Suggested (1)	4.0 (100)	7.0 (180)	232 (21.6)
Minimum	2.0 (50)	3.5 (90)	465 (43.2)
Maximum	6.0 (150)	10.5 (265)	155 (14.4)

(1) Note: Roller or brush application may require two or more coats to obtain suggested film thickness. Allow for overspray and surface irregularities. Film thickness is rounded to the nearest 0.5 mil or 5 microns. Application of coating below minimum or above maximum recommended dry film thicknesses may adversely affect coating performance.

MIXING

Power mix contents of each container, making sure no pigment remains on the bottom. Pour a measured amount of Part B into a clean container large enough to hold both components. Add an equal volume of Part A to Part B while under agitation. Continue agitation until the two components are thoroughly mixed. Do not use mixed material beyond pot life limits. **Note:** Both components should be above 50°F (10°C) prior to mixing. For application to surfaces between 35°F to 50°F (2°C to 10°C), allow mixed material to stand thirty (30) minutes and restir before using. For optimum application properties, blended components should be above 60°F (16°C). **Note:** Mixing ratio is one to one by volume.

POT LIFE

16 hours at 35°F (2°C) 2 hours at 75°F (24°C) ½ hour at 100°F (38°C)

THINNING

Use No. 4 Thinner. For air spray, thin up to 10% or ¼ pint (380 mL) per gallon. For airless spray, roller or brush, thin up to 5% or ¼ pint (190 mL) per gallon.

SURFACE TEMPERATURE

Minimum 35°F (2°C) Maximum 135°F (57°C) The surface should be dry and at least 5°F (3°C) above the dew point. Coating will not cure below minimum surface temperature.

APPLICATION EQUIPMENT

Air Spray

Gun	Fluid Tip	Air Cap	Air Hose ID	Mat'l Hose ID	Atomizing Pressure	Pot Pressure
DeVilbiss MBC or JGA	E	765 or 78	5/16" or 3/8" (7.9 or 9.5 mm)	3/8" or 1/2" (9.5 or 12.7 mm)	75-100 psi (5.2-6.9 bar)	10-20 psi (0.7-1.4 bar)

Low temperatures or longer hoses require higher pot pressure.

Airless Spray

Tip Orifice	Atomizing Pressure	Mat'l Hose ID	Manifold Filter
0.015"-0.019" (380-485 microns)	1800-3000 psi (124-207 bar)	1/4" or 3/8" (6.4 or 9.5 mm)	60 mesh (250 microns)

Use appropriate tip/atomizing pressure for equipment, applicator technique and weather conditions. **Note:** Application over inorganic zinc-rich primers: Apply a wet mist coat and allow tiny bubbles to form. When bubbles disappear in 1 to 2 minutes, apply a full wet coat at specified mil thickness.

Roller: Roller application optional when environmental restrictions do not allow spraying. Use 3/8" or 1/2" (9.5 mm or 12.7 mm) synthetic nap covers.

Brush: Recommended for small areas only. Use high quality natural or synthetic bristle brushes.

CLEANUP

Flush and clean all equipment immediately after use with the recommended thinner or MEK.

*Values may vary with color.

WARRANTY & LIMITATION OF SELLER'S LIABILITY: Tnemec Company, Inc. warrants only that its coatings represented herein meet the formulation standards of Tnemec Company, Inc.

THE WARRANTY DESCRIBED IN THE ABOVE PARAGRAPH SHALL BE IN LIEU OF ANY OTHER WARRANTY, EXPRESSED OR IMPLIED, INCLUDING BUT NOT LIMITED TO, ANY IMPLIED WARRANTY OF MERCHANTABILITY OR FITNESS FOR A PARTICULAR PURPOSE. THERE ARE NO WARRANTIES THAT EXTEND BEYOND THE DESCRIPTION ON THE FACE HEREOF. The buyer's sole and exclusive remedy against Tnemec Company, Inc. shall be for replacement of the product in the event a defective condition of the product should be found to exist and the exclusive remedy shall not have failed its essential purpose as long as Tnemec is willing to provide comparable replacement product to the buyer. NO OTHER REMEDY (INCLUDING, BUT NOT LIMITED TO, INCIDENTAL OR CONSEQUENTIAL DAMAGES FOR LOST PROFITS, LOST SALES, INJURY TO PERSON OR PROPERTY, ENVIRONMENTAL INJURIES OR ANY OTHER INCIDENTAL OR CONSEQUENTIAL LOSS) SHALL BE AVAILABLE TO THE BUYER. Technical and application information herein is provided for the purpose of establishing a general profile of the coating and proper coating application procedures. Test performance results were obtained in a controlled environment and Tnemec Company makes no claim that these tests or any other tests, accurately represent all environments. As application, environmental and design factors can vary significantly, due care should be exercised in the selection and use of the coating. **FOR INDUSTRIAL USE ONLY.**

Surface Preparation Standards

System	SSPC Codes	NACE	CDN. Govt. (CGSB)	Swedish Standard	British Standard
Solvent Clean	SSPC.SP1 SP1 Definition				
Hand Tool Clean	SSPC.SP2 SP2 Definition		31 GP 401	St. 2 (approx.)	
Power Tool Clean	SSPC.SP3 SP3 Definition		31 GP 402	St. 3	
Flame Clean (new steel)	SSPC.SP4		31 GP 403		
White Metal Blast	SSPC.SP5 SP5 Definition SP5 Picture	NACE #1	31 GP 404 Type 1	Sa. 3	BS4232 First Quality
Commercial Blast	SSPC.SP6 SP6 Definition SP6 Picture	NACE #3	31 GP 404 Type 2	Sa. 2	BS4232 Third Quality
Brush Off Blast	SSPC.SP7 SP7 Definition SP7 Picture	NACE #4	31 GP 404 Type 3	Sa. 1	Light blast to brush-off
Pickling	SSPC.SP8				
Weather and Blast	SSPC.SP9				
Near White Blast	SSPC.SP10 SP10 Definition SP10 Picture	NACE #2		Sa. 2 ½	BS4232 Second Quality
Power Tool Cleaning to Bare Metal	SSPC.SP11 SP11 Definition				

Non-Ferrous Metals

Aluminium
[Definition](#)

Brass, Bronze, Copper, Lead, Terne [Definition](#)

Galvanized Metal
[Definition](#)

Brush Off Blast SSPC-SP10 (SSI-Sa2 ½), or NACE #2 Definition:

In this method, all oil, grease, dirt, mill scale, rust, corrosion products, oxides, paint or other foreign matter have been completely removed from the surface by abrasive blasting, except for very light shadows, very slight streaks or slight discolorations caused by rust stain, mill scale oxides or slight, tight residues of paint or coating. At least 95% of each square inch of surface area shall be free of all visible residues, and the remainder shall be limited to the light discolorations mentioned above. From a practical standpoint, this is probably the best quality surface preparation that can be expected to today for existing plant facility maintenance work.

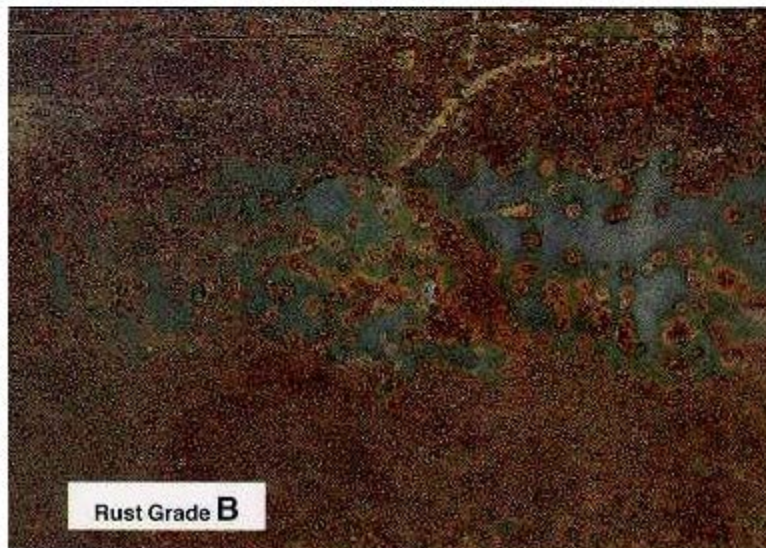

Catalogue Water Management 2014/2015

Drainage and Sewage – Wastewater Treatment

Submersible mixers, axial pumps, recirculation pumps,
jet cleaners, grit collector pumps and accessories



Ceram coating

The Ceram coating is also very well suited for use in maritime environments. For its Ceram C0 coating, Wilo grants a guarantee of 5 years for use in seawater. The prerequisite is that the coating is intact

Increase efficiency, reduce costs

Since water is being used more and more economically, the proportion of contaminants is increasing relative to the amount of water. This means that the concentration of corrosive and abrasive constituents is higher.

Sewage units are always exposed to this aggressive fluid. Corrosion and abrasion affect the surfaces and material structures of the units, sometimes with considerable impairments to the material, and thus also the performance.

This significantly reduces the hydraulic efficiency. This results in the units having an increased current consumption. On the other hand, the pumps no longer work at their optimum, the radial forces increase, there is more stress on the bearings and mechanical seals, and the service life of the machines is reduced.

When standard materials are used, such as grey cast iron, under high stress, it may be necessary to exchange the components already after 500 hours of operation. Ceram coatings allow the service life to be increased by a factor of 4, and this at the same high efficiency, which means minimum energy costs.

If one takes the overall costs over the entire service life of the pump into account, the investment costs for a unit coated with Ceram are less than 10%, and thus negligible. On the other hand, there is a high savings potential due to the fact that fewer repairs are required, resulting in a significant reduction of system downtimes. The amortisation is then usually quickly reached due to the higher efficiency.



Use of the various Ceram qualities

- Ceram C0 is used for the complete outer and inner coating. It's ideally suited for corrosion protection.
- Ceram C1 is used for the inner coating of pump components. The main field of application is the coating of the impeller and the suction port.
- Ceram C2 and C3 are used for the inner coating of pump components. The main field of application is the coating of the pump housing.

In order to guarantee protection even in especially aggressive and corrosive fluids, the Ceram types are combined with each other, e.g. C2 + C1 or C3 + C1.

Ceram coating

Ceram C0 – Technical data

Description

Ceram C0 is a sprayable, solvent-free two-component polymer coating substance with an aluminium oxide basis for protecting our products against corrosion when there is additional strong mechanical stress.

Composition

Solvent-free epoxy polymer with solvent-free polyamine hardener and various extenders.

Features

- Tough and durable coating with high mechanical and chemical resistance and very good abrasion resistance.
- Excellent wet adhesion and compatibility with cathodic corrosion protection as single-layer coating on steel surfaces.
- Very good adhesion to steel surfaces.
- Replaces bituminous coatings.
- Saves costs due to the long service life, low maintenance and easy repair ability.
- Tested by the "Bundesanstalt für Wasserbau" (German Federal Institute for Hydraulic Engineering) (BAW).
- Solvent-free.
- Hardened coating has a high-gloss finish.

Technical data

Density (mixture) adhesive strength/steel	ASTM D 792 ISO 4624	1.4 g/cm ³ 15 N/mm ²
Impact resistance / strength	DIN EN ISO 6272	9 J
Temperature resistance: dry, long-term		60 °C
Temperature resistance: dry, short-term		120 °C
Temperature resistance: wet / liquid	Depending on the fluid; on request	
Solid content (mixture)	Volume Weight	97 % 98 %

Resistance table

Fluid	Temperature	Factor
Sewage, alkaline (pH 11)	+20 °C	1
Sewage, alkaline (pH 11)	+40 °C	1
Sewage, slightly acidic (pH 6)	+20 °C	1
Sewage, slightly acidic (pH 6)	+40 °C	1
Sewage, highly acidic (pH 1)	+20 °C	2
Sewage, highly acidic (pH 1)	+40 °C	3
Ammonium hydroxide (5%)	+40 °C	3
Decanol (fatty alcohol)	+20 °C	1
Decanol (fatty alcohol)	+50 °C	1
Ethanol (40%)	+20 °C	1
Ethanol (96 %)	+20 °C	3
Ethylene glycol	+20 °C	1
Heating oil/diesel	+20 °C	1
Compressor oil	+20 °C	1
Methyl ethyl ketone (MEK)	+20 °C	3
Caustic soda (5%)	+20 °C	1
Caustic soda (5%)	+50 °C	2
Sodium chloride solution (10%)	+20 °C	1
Hydrochloric acid (5%)	+20 °C	2
Hydrochloric acid (10 %)	+20 °C	2
Hydrochloric acid (20 %)	+20 °C	3
Sulphuric acid (10%)	+20 °C	2
Sulphuric acid (20 %)	+20 °C	3
Nitric acid (5%)	+20 °C	3
Toluene	+20 °C	2
Water (cooling/industrial water)	+50 °C	1
Xylene	+20 °C	1

Key: 1 = resistant; 2 = short-term resistant; 3 = overflow resistant, immediate cleaning; 4 = not recommended for direct contact

TECHNICAL REQUIREMENTS – ATTACHMENT 5

Location of facilities for manufacturing (foundry, machining and assembly) and factory witness testing.

Reducers

All components of the speed reducers are founded and machined in Germany. The final assembly, quality assurance and testing is done in Elgin, IL prior to the shipment of the equipment to the project site. The equipment is no load tested for 4 hours or until the temperature of the oil has stabilized. This significantly reduces the chance that oil leaks may occur during operation.

Motors

The motors are machined, assembled and tested in Athens, GA. Once the motor fabrication is complete the motor is sent to the reducer manufacturer's facility to be mounted to the reducer to check equipment fit and function and match mark the motor to the reducer to allow ease of installation by the installing contractor.

Steel

The steel components are fabricated in Pell City, AL. Ovivo has fabricated all equipment for Carrousel installations in the same facility for the past 20+ years. This has allowed us to maintain very high standards of quality for all fabricated steel equipment provided by Ovivo.

Controls

The motor control center and control panels are designed by Ovivo and fabricated in either Utah or Arizona. This allows Ovivo control engineers to be intimately involved in the fabrication process. All motor control centers and control panels are factory acceptance tested prior to leaving the fabrication facility. This ensures that the controls are ready for installation by the installing contractor and can be quickly commissioned for successful operation.

Instrumentation

Instrumentation is designed and manufactured in Loveland, CO and Ames, IA. Instrumentation is quality tested prior to leaving the manufacturing facility.

TECHNICAL REQUIREMENTS – ATTACHMENT 6

Plan and schedule indicating dates for submittals, manufacturing, testing, and delivery.

If Ovivo is selected as the equipment supplier for the Pflugerville, TX Central WWTP expansion project, we would continue to provide support and technical details pertaining to the selected equipment throughout the remainder of the design phase. Ovivo is committed to ensuring a successful project as has been demonstrated by the support provided thus far. Ovivo was also the provider of the provider of the currently operating equipment at the Pflugerville WWTP as well as the equipment before that. Ovivo recognizes the City of Pflugerville as a valuable customer and would like to maintain that relationship moving forward.

Once Ovivo receives the Purchase Order for the equipment or the notice to proceed, the submittal process will begin. This process typically takes 8 weeks to generate engineering drawings and appropriate documentation that will be presented to the approving committee, often this time can be reduced based on current workload of the engineering staff, especially since much of the design work would be completed during the remainder of the design process after a manufacturer is selected.

Ovivo typically plans on 4 weeks' time for the approving committee to review the documentation and drawings and return the submittals with any comments or concerns that need to be addressed. Any comments made will be addressed and equipment will be ordered.

The long lead item is the gear reducer. This component is shipped from overseas and takes roughly 24 weeks to fabricate and ship to the project site. Generally Ovivo prefers to order this item in advance to allow more of a buffer in the project schedule. In order to do so, Ovivo would provide a submittal for just the gear reducer shortly after the notice to proceed and ask that the approving committee review information supplied for the reducer at that time so that the reducer may be placed on order in advance of the rest of the equipment. **This could potentially save about 8 weeks of equipment delivery time** and allow for any variations in the schedule due to weather or product availability.

Ovivo will maintain communication with the installing contractor during the entire construction process to answer any questions that may arise during the construction of the new basins and the installation of the equipment. Once the equipment is installed inspections will be scheduled to verify correct installation of the equipment followed by the startup of the equipment.

When the equipment is deemed to be operating satisfactorily, the process performance test will begin. An estimate of the project's timeline is listed below.

PHASE 1 PROJECT SCHEDULE	
EVENT	CALENDAR DAYS
Submittal	56
Return Submittal	28
Order Reducer	0
Deliver Equipment	168
Install Equipment*	56
Substantial Completion	308
Start Performance Testing	60
Final Completion*	343

*This is an assumed timeline based on past experience with projects of this size. This will vary based on the installing contractors experience, resources and organization.

The substantial completion date may also change based on how long it takes the contractor to construct the basin. This schedule assumes that the basins would be completed in the time that has been allotted to deliver the equipment.

Phase 2 of the project would proceed similarly however since the basin only requires modification instead of complete construction. We would highly recommend that the reducers be pre-ordered for Phase 2 to avoid delays due to equipment lead times.

TECHNICAL REQUIREMENTS – ATTACHMENT 7

Equipment provided by Ovivo will meet the warranty requirements contained in the Procurement Contract, including Specification 01 78 36 and the following specifications for both the Phase I Project and the Phase II Project, except as modified herein:

Specification section 46 53 61 – Carousel Style Biological Nutrient removal (BNR) System (Phase I), indicates that the warranty shall be in effect until 2 years after the installation, adjusting and acceptance testing and the actual operation of the equipment or 3 years after delivery, whichever occurs first.

Specification section 46 53 61.01 – Carousel Style Biological Nutrient removal (BNR) System (Phase II), indicates that the warranty shall be in effect until 2 years after the installation, adjusting and acceptance testing and the actual operation of the equipment or 3 years after delivery, whichever occurs first.

Specification section 01 78 36.1.05.A – Correct defective Good during the one-year correction period in accordance with the General Conditions unless specifically indicated as required otherwise in the specifications.

EXCEPTION: For Citel America, Incorporated, brand Surge Protection Devices (SPD) utilized on the Ovivo provided equipment, Citel's Produce Warranty shall be provided. Citel's Product Warranty is for a service period of 10 years from date of manufacture. The warranty period for repaired or replacement SPD will be only the remaining portion of the original 10-year Product Warranty, per Citel's Product Warranty.

Warranty

Seller warrants equipment and parts manufactured by it and provided to Buyer (collectively, "Products") shall be free from defects in material and workmanship. The warranty period shall be twenty-four (24) months from startup of the equipment not to exceed thirty-six (36) months from shipment. If it is determined after inspection that Seller is liable under this warranty to repair or replace the Product or part thereof, Seller shall bear the transportation costs of (a) returning the Product to Seller for inspection or sending its representative to the job site and (b) returning the repaired or replaced Products to Buyer; however, if it is determined after inspection that Seller is not liable under this warranty, Buyer shall pay those costs.

For Seller to be liable with respect to this warranty, Buyer must make its claims to Seller with respect to this warranty in writing no later than thirty (30) days after the date Buyer discovers the basis for its warranty claim and in no event more than thirty (30) days after the expiration of the Warranty Period. In addition to any other limitation or disclaimer with respect to this warranty, Seller shall have no liability with respect to any of the following: (i) failure of the Products, or damages to them, due to Buyer's negligence or willful misconduct, abuse or improper storage, installation, application or maintenance (as specified in any manuals or written instructions that Seller provides to the Buyer); (ii) any Products that have been altered or repaired in any way without Seller's prior written authorization; (iii) The costs of dismantling and reinstallation of the Products; (iv) any Products damaged while in transit or otherwise by accident during a time when the risk of loss is assigned to the Buyer; (v) decomposition of Products by chemical action, erosion or corrosion or wear to Products or due to conditions of temperature, moisture and dirt unless the specifications require protective measures against such decomposition and the defect in or failure of such measures allow such decomposition; or (vi) claims with respect to parts that are consumable and normally replaced during maintenance, except where such parts are not performing to Seller's estimate of normal service life, in which case, Seller shall only be liable for the pro rata cost of replacement of those parts based on Seller's estimate of what the remaining service life of those parts should have been; provided, that failure of those parts did not result from any of the matters listed in clauses (i) through (v) above.

THE PARTIES AGREE THAT ALL OTHER WARRANTIES, EXPRESS OR IMPLIED, INCLUDING WARRANTIES OF FITNESS FOR A PARTICULAR PURPOSE AND MERCHANTABILITY, WHETHER WRITTEN, ORAL OR STATUTORY, ARE EXCLUDED TO THE FULLEST EXTENT PERMISSIBLE BY LAW. All warranties and obligations of Seller shall terminate if Buyer fails to perform its obligations under this Agreement including but not limited to any failure to pay any charges due to Seller.



Daniel Kirby
Aeration Process Group Product Manager

TECHNICAL REQUIREMENTS – ATTACHMENT 8

List of spare parts to be provided and included in the prices stated in the Price Proposal.

Phase 1

Aerators

1. (1) High speed flexible coupling
2. (3) High speed flexible coupling inserts
3. (1) Oil sensing cutout switch

Mixers

1. (1) Set of bearings, mechanical seals and o-rings for each mixer provided

Control Panels

1. (6) Replacement fuses, all types and sizes
2. (1) Starter coil for each NEMA size furnished

Motor Control Center

1. (3) Control fuses of each type used
2. (1) Replacement lamp of each color for pilot lights
3. (1) Replacement lens of each color for pilot lights
4. (12) Cover bolts, spring nuts and door fasteners.
5. (1) Quart of touch up paint

Phase 2

Aerators

1. (1) High speed flexible coupling
2. (3) High speed flexible coupling inserts
3. (1) Oil sensing cutout switch

Mixers

1. (1) Set of bearings, mechanical seals and o-rings for each mixer provided

Control Panels

1. (6) Replacement fuses, all types and sizes
2. (1) Starter coil for each NEMA size furnished

Motor Control Center

1. (3) Control fuses of each type used
2. (1) Replacement lamp of each color for pilot lights
3. (1) Replacement lens of each color for pilot lights
4. (12) Cover bolts, spring nuts and door fasteners.
5. (1) Quart of touch up paint

TECHNICAL REQUIREMENTS – ATTACHMENT 9

Lisa M. Powers

(801) 946-9938

Lisa.Powers@Oviovowater.com

EXPERIENCE:

Ovivo USA, Salt Lake City, UT – Operations Manager

JULY 2014 – Present

Lead the Process Aeration Operations Team in successfully executing Capital and Rebuild Projects with an average backlog of over \$45 million dollars. Consistently meet financial goals set for the department. Plan and manage departmental budgets and forecasts. Direct, evaluate and coach team members including project managers, mechanical engineers, and controls engineers. Establish project schedules and milestones for team members.

Negotiate contract terms and conditions with customers and vendors. Emphasis on meeting on-time deliveries while regularly improving expected project margins. Work closely with key individuals to resolve problematic issues with customers and vendors to ensure project and company objectives are met.

Foster strong relationships with regional sales representatives, customers, contractors, design engineers and city representatives/plant operators. Coordinate closely with other product line teams on joint projects. Advise colleagues within the organization on critical business decisions to ensure successful results in difficult situations.

Travel extensively for pre-construction meetings, equipment startup and testing, troubleshooting equipment issues, and end user training.

Ovivo USA (EIMCO Water Technologies), Salt Lake City, UT – Project Manager

OCTOBER 2008 – JULY 2014

Managed Capital Projects for the Process Aeration Team. Reviewed project contracts, specifications, plans and equipment submittals. Consulted with marketing team to assess potential issues with scope and delivery. Coordinated with team members to consistently meet project delivery schedules and projected budgets. Functioned as first point of contact between customers and Ovivo. Conducted installation check out, startup, and operator training. Negotiated back charges and warranty issues with customers.

Assisted the department marketing team with budgets for bidding projects, specifically with controls. Reviewed project bid documents.

EIMCO Water Technologies, Salt Lake City, UT – Marketing Coordinator

SEPTEMBER 2008 – OCTOBER 2008

Contacted existing customers to update Prime Database and identify potential leads for equipment upgrades. Worked directly with the marketing and operations teams.

Compiled equipment Operation and Maintenance Manuals.

Precision Automated Technology, North Salt Lake City, UT – *Administrator*

APRIL 2007 – SEPTEMBER 2008

Distributed payroll, accounts receivable and accounts payable. Prepared and filed monthly and quarterly tax returns. Ordered, received, and tracked parts inventory. Created and maintained customer databases. Coordinated with vendors and clients for project deliveries.

Neurology Learning and Behavior Center, Salt Lake City, UT – *Account Manager*

APRIL 1998 – APRIL 2007

Coordinated psychological service pre-authorizations with insurance providers. Initiated follow-up and resolved disputed insurance claims. Tracked patient accounts and collectables. Represented the clinic in court collection cases. Assisted staff psychologists with patients, administered neuropsychological computer screening tests, and compiled manuscripts for psychological texts and resource books.

Victim Resource Center, Salt Lake City, UT – *Volunteer Victim Advocate*

JANUARY 1998 – DECEMBER 1998

Answered domestic violence victim hotline calls and responded to domestic violence crime scenes in cooperation with the Salt Lake City Police Department. Provided resource referrals to victims, followed-up with victims, and completed appropriate program paperwork. Participated in on-going self-education of programs and support available in the community to address domestic violence issues and resolutions. This was a volunteer position.

DFW Enterprises, Salt Lake City, UT – *Sales Coordinator*

OCTOBER 1995 – MARCH 1998

Drafted new and reviewed existing drug testing policies and procedures for clients. Implemented and managed employee drug testing programs. Conducted training and employee orientation on testing policies and procedures. Updated and monitored random drug testing selection databases. Administered drug and alcohol screenings for pre-employment, random and post-accident conditions. Planned and implemented marketing strategies for client development.

Donald Clark Associates (Western Area Power Administration-Department of Energy), Salt Lake City, UT – *Administrative Assistant*

APRIL 1990 – OCTOBER 1995

Scheduled training and travel for employees, tracked employee service awards, and updated employment records in the Department of Energy's main database. Drafted confidential personnel documents and addressed employee questions and concerns. Served as Secretary of the Equal Employment Opportunity (EEO) Committee and Employee Association.

EDUCATION:

Continuing Education, University of Utah
Attended classes in Electrical Engineering

Bachelor of Science, Weber State University, May 2004
Major: Criminal Justice
Minor: Psychology

Associate of Science, Weber State University, May 1999
General Education, Honors

SPECIAL PROJECTS:

Lower Lackawanna Valley Sanitary District

Selected to assume responsibility for managing the Lower Lackawanna project. Coordinating with plant personnel, vendors, design engineers, outside consultants and management to identify and resolve process issues at the plant with the goal of increasing performance and meeting permit requirements. Meet with plant operators at the plant every few weeks, perform lab testing, and make recommendations based on data and observations. Manage construction and service activities at the plant.

Liberty Wastewater Treatment Facility, Water Expert

Coordinating with the Water Expert design team to implement end user remote access to the controls system. Working closely with the City Information Technology Department and plant operators on successfully installing the system while meeting their prescribed security requirements.

Oculus Controls System

Undertook the role of controls expert at a time the department Controls Engineer position was vacant to mitigate potential margin losses. Worked directly with vendors, integrators and third party experts to design and implement a strong controls system. Developed controls strategies, scope, flowcharts, end user screens, and training documentation. Prepared and presented the launch of the new control system to the National Sales Representative Conference. To date this system is the foundation of current project controls strategies.

Snapfinger Wastewater Treatment Facility

Lead Project Manager on the Snapfinger project. This project is the largest Carrousel project currently under construction.

Customer Relationship Management (CRM) and WaterExpert™

Assisted the Digital Team in the development and release of the Customer Relationship Management system internally. Program sponsor in the development of internal training on the CRM system. Oversaw the Project Management aspect of WaterExpert™ in meeting deliverables for the new product line.

ADDITIONAL SKILLS:

- Experienced in wastewater treatment process and equipment.
- Strong knowledge of financial and accounting practices.
- Trained in SPIN Selling, Systematic Innovative Thinking (SIT), and negotiations.
- Solid understanding of control systems.
- Accomplished in written and verbal communication.
- Proficient in Microsoft Office software, Syteline, remote access software, CRM and WaterExpert™ software.
- Experienced in Autodesk Vault software.

TECHNICAL REQUIREMENTS – ATTACHMENT 10

Barry L. Mercer

11693 West 75th Circle | Arvada, Colorado |(303) 456-7607
bymerce4@msn.com

Summary

Self-motivated with a diverse background in programmable logic controllers, touchscreen controllers, sensors, air solenoids, micro-switches, and many different types of meters. I have worked for the same company for 15 years and have traveled extensively worldwide commissioning new equipment and re-building existing equipment, with some experience in aftermarket sales. Looking for a long term position that will be both challenging and fulfilling.

Employment

Ovivo USA, LLC

Salt Lake City, Utah.

October, 1989 – present

- Complete mechanical check out and start up on water process equipment.
- Write programs and modify existing programs for programmable logic controllers. Some of the P.L.C.'s that I have had experience with are Idec fa2J, Allyn-Bradley slc500/plc5, Square D, G.E. Fanuc, and Modicon
- Assist customers in assessing their needs when the time comes to re-building existing equipment
- Provide operator training to customers with new equipment
- Provide aftermarket sales support to help the customer keep their equipment operational

Meurer Research Inc. Arvada, Colorado. Field Service

August 1987 – October 1989

- Complete mechanical checkout and start up on water process equipment
- Write programs and modify existing programs for programmable logic controllers
- Provide operator training and aftermarket sales and support

Den-West Consultants Lakewood, Colorado. Survey party chief.

February 1984 – August 1987

- Complete construction layout for housing subdivisions and road building
- Drafting

Education

Northeastern Jr. College
Sterling Colorado

Denver Institute Of Technology
Denver Colorado
Surveying and drafting

Fred P. Simano

22481 Southshore Dr. | Land O Lakes, FL. 34639 | (813) 625-0611

E-mail: fsimano@yahoo.com Cell:

HIGHLIGHTS:

- Performed inspection, start up and training for over 125 waste water and fresh water treatment facility projects on clarifier and aeration equipment across the USA.
- Instructed over 425 Plant Operators, onsite, in Clarifier, Aerator and mixer operation and maintenance with 100% satisfaction in material presentation.
- Course Manager of the Navy’s Construction Inspector Program for over 4 years as the advanced technical instructor for Sanitary Systems and waste water treatment.
- General Contractor License.
- Executive committee member to determine cost reduction and process revisions.
- Traveled extensively throughout Europe, South America and Japan, Supervising construction and maintenance in classified government facilities
- Managed over one million dollars in security surveillance and repair equipment while attached to the U.S. Department of State.
- Successfully instructed and graduated over 200 senior construction technicians from 8 different trades with a failure rate of zero and average grade of 92%
- Managed and supervised over 15 construction projects while attached to the US Navy Seabees..
- Construction Quality Control Inspector for 25 projects.

EMPLOYER:

- Ovivo USA, LLC / Southeast Waterworks April 2007 to Present
- David Weekley from May 2001 to April 2007.
- Watermark Communities Inc. From June 1999 to May 2001.
- United States Department of Defense Navy Seabees from August 1978 to June 1999.

EDUCATION:

- Cam Tech School of Construction Tampa Florida 128hrs.
- Uniform Building Codes Ventura Community Collage, Ventura Ca. 32 hrs.
- Uniform Plumbing Code Ventura Community Collage, Ventura Ca. 32 hrs
- Uniform Mechanical Code Ventura Community Collage, Ventura Ca. 32 hrs

TRAINING:

- | | | |
|---|--|---|
| United States Navy Seabee Construction Inspector Course | | 360 Hours |
| <ul style="list-style-type: none"> • Contracts • Site Preparation • Site Utilities • Structural Framing (Steel/Wood) | <ul style="list-style-type: none"> • Heavy Timber Construction • Plans and Specification • Electrical Service • Sanitary Systems | <ul style="list-style-type: none"> • Plumbing Systems • Pile Driving Operations • Surveying • Concrete/Masonry Construction |
| United States Navy Instructor School | | 180 Hours |
| <ul style="list-style-type: none"> • Curriculum Development • Motivation • Learning Objectives | <ul style="list-style-type: none"> • Effective Communications • Principles of Learning • Testing | <ul style="list-style-type: none"> • Instructional Presentations • Instructional Methods • Course Materials |
| United States Navy Builder School | | 650 Hours |
| <ul style="list-style-type: none"> • Commercial Construction | <ul style="list-style-type: none"> • General Construction | |
| United States Department of State Diplomatic Security Technicians School | | 300 Hours |
| <ul style="list-style-type: none"> • Foreign Construction Security Surveillance • Closed Circuit Television Systems • Anti-Terrorist Vehicle Barrier Systems • Safe Maintenance and Entry | | <ul style="list-style-type: none"> • Electronic Repair • Paper Shredder Repair • Locksmith |

COMPUTER SKILLS:

- Skilled in the use of word processing and database integration, spreadsheet use, presentation development and implementation.
- Microsoft Access, word, Excel, Power Point, Lotus Organizer and Mail, Photo Editor, Project Planning, Inspection Programs, Internet based programs for company operations.

SPECIALIZED TRAINING:

- Red Cross CPR/Emergency First Aid Training
- Sexual Harassment Awareness Training for Supervisors
- Alcohol and Drug Awareness for Supervisors
- Safe Working Practices
- General Health and Safety Policy
- Accident Reporting and Investigation
- Chemical Plant Safety and Security
- Confined Space Entry
- Equal Opportunity Training for Supervisors
- Suicide Prevention/Awareness for Supervisors
- Personal Protective Equipment
- Bloodborne Pathogens
- Control of Stored Energy (Lockout/Tagout)

CLEARANCES HELD:

- Top Secret

AWARDS:

- Navy Achievement Medal for Superior performance of project management..
- Coast Guard Special Operations award for Haitian exodus while working in Guantanamo Bay, Cuba.
- Letter of Commendation from U.S. Ambassador to France for superior performance of duties.
- Medallion Seal from Central Intelligence Agency for superior performance of duties.



Joseph Scott Bailey

3910 Allen Road | Jarratt, VA 23879 | (801) 831-4735

Dates	Company	Job Title and Duties
5/14 – Present	Ovivo USA LLC 4246 Riverboart Rd, Ste. 300 Salt Lake City, UT 84123	Title: Field Service Engineer Duties: Complete mechanical check out and start up on water process equipment. Assist customers in assessing their needs when the time comes to re-building existing equipment. Provide operator training to customers with new equipment. Provide aftermarket sales support to help the customer keep their equipment operational. OSHA “Confined Spaces” training certified.
4/04 – 5/14	Mid-Eastern Builders 4016 Holland Boulevard Chesapeake, VA 23323 (804) 400-2628 Contact: Dickie Clark	Title: Superintendent Duties: Excavation and construction of WTP, WWTP & pump stations ect..., including concrete slabs, walls, buildings, interior and exterior piping. Supervision of MEB personnel and five subcontractors. This included tracking labor, construction schedules and job site safety.
4/03 – 4/04	Quality Plus Services 2929 Quality Drive Petersburg, VA 23805 (804) 863-0191 Contact: Tom Greise	Title: Superintendent Duties: Build by plans and specs two 16,000 square foot office buildings. Supervision of six QPS personnel and subcontractors. This included tracking labor, construction schedules, estimating and job site safety
2/99 – 4/03	English Construction 910 WRVA Road Sandston, VA 23150 (804) 221-6584 Contact: Gene Gluegalsky	Title: Structural Foreman / Superintendent Duties: Excavation and construction of concrete slabs, walls and buildings. Supervision of English personnel and three subcontractors. This included tracking labor, construction schedules and job site safety.
4/96 – 1/99	Morgan Construction 2928 W. Strathmore Road Richmond, VA 23234 (804) 926-7674 Contact: Jerry Morgan	Title: Foreman Duties: Lay out for framing and siding of new houses and churches. Supervision of six Morgan personnel. . This included tracking labor, payroll, construction schedules and job site safety.
9/94 – 4/96	Dagenhart Sprinkler Co. 5400 Glen Allen Drive Richmond, VA 23111 (804) 226-1122 Contact: Bill Plularis	Title: Pipe Foreman Duties: Fabricate and fit pipe according to prints and specifications. Oversee 1 helper.

Equipment:		Certificates:
Track hoes:	All Models	Hydraulic Cement Testing and Inspection Certification
Loaders:	CAT 963 and 953	CPR Training
Backhoes:	CAT 416	Hilti Shot Certified
Skid steers:	Bobcat, John Deer, and CAT	Crosby Rigging & Training Certification
Cranes:	American 75 ton, Link belt 100 ton	OSCHA 30 hr
All-terrain Cranes:	Grove 60 ton, Terex 60 ton	20 hr Trench Safety

References:		
Gene Hallingshead	(434) 634-9468	Construction Superintendent
Dickie Clark	(804) 400-2628	Construction Superintendent
Gene Gluegalsky	(804) 221-6584	Field Superintendent

TECHNICAL REQUIREMENTS – ATTACHMENT 11

Tom W. Leland, P.E.

1247 E. Laird Ave • Salt Lake City, Utah 84105 •
USA (801) 573-6948 • tomwleland@yahoo.com

SUMMARY

Registered professional civil engineer (PE) with over 25 years experience relating to biological process and aeration design, civil construction, environmental project commissioning (start-up), and activated sludge process training. **International** experience developing and implementing a 100-hour operator training program for a new 300 m³/hr (2 MGD) activated sludge wastewater treatment plant in Malaysia. Perform 100 hours+ per year of wastewater operator training (approved for CEUs in Ohio, Florida, Kentucky, elsewhere).

PROFESSIONAL EXPERIENCE

Ovivo USA, LLC

2003-present

(Supplier of water and wastewater process design and equipment)

Group Manager and Biological Process Engineer, Salt Lake City, UT (2003-present)

Manage process team and provide process design and operational support to engineers and plant operators relating to municipal biological wastewater treatment plants.

- Manage team of 15-20 engineers
- Perform process calculations and provide activated sludge designs for aeration and process volumes for over 50 projects per year.
- Conduct 5-10+ on-site operator training and workshops courses per year
- Perform performance testing of aeration equipment in wastewater treatment plants.
- Provide process technical support to operators at over 700 biological treatment plant sites.

The Dow Chemical Company

1996-2002

(a large international chemical manufacturing firm)

Operations Improvement Engineer, Kerteh, Malaysia (2001-2002)

Managed construction and commissioning of a 300 m³/hr (2 MGD) wastewater treatment plant and a 2.8 ha (7 ac) Biosolids Landfarm for eight new petrochemical plants (*Build-Operate-Transfer* model).

- Achieved 100% permit compliance by developing and implementing a 100-hour training and certification program for 25 new inexperienced wastewater plant operators and engineers.
- Ensured biological process control by writing and implementing over 30 operating and laboratory procedures and a comprehensive performance monitoring system.

Project Engineer, Marietta, Ohio (1999-2001)

Engineered remedy for a multi-million dollar Superfund site including: treating site wastewater, mitigating slope instability, designing four hazardous waste landfill caps, restoring 600 m (2000 ft) of a contaminated creek, and relocating 15,000 m³ (20,000 yd³) of dioxin contaminated soil.

- Performed biological treatability study, determined design parameters (SRT, loadings, etc.) and selected equipment for on-site treatment of petrochemical wastewater.
- Won stakeholder acceptance by chairing 20 public and government agency technical meetings.

The Dow Chemical Company – continued

Senior Engineer, South Charleston, West Virginia (1996-1999)

Managed over 15 wastewater and environmental remediation projects in the U.S., U.K., and Canada.

- Calculated tank size, aeration requirements, and sludge production for a future 20 gpm activated sludge plant.
- Reduced Cu and Zn discharge by 80% by implementing a pollution prevention program, installing ion exchange, and improving plant operation at a small, rural activated sludge plant.
- Improved data quality and achieved EPA lab certification by supervising wastewater laboratory technicians conducting standard analyses (BOD, TSS, NH₃-N, etc.).

Utah Water Research Laboratory

1993-1996

(affiliated with Utah State University; conducts research for environmental engineering projects)

Research Assistant, Logan, Utah

Developed quality control and quality assurance plans. Conducted field and laboratory analysis.

- Taught wastewater laboratory class for 30 students.
- Reduced potential soil remediation costs by 90% after demonstrating efficacy of new passive treatment technology (phytoremediation--using grasses and other plants for soil clean-up).

Goplen Excavating and Engineering Contractors

1987-1993

(a small general engineering contracting company performing earthmoving projects up to \$2 million)

Chief Estimator, Santa Monica, California

Wrote 100 proposals each year to win construction contracts and managed environmental projects.

- Reviewed civil and structural drawings, performed quantity take-offs, estimated costs, and interpreted engineering reports for over 100 projects per year.
- Increased company contracts by 50% by training and supervising four estimators.

EDUCATION

M.S., Environmental Engineering, Utah State University, Logan, Utah - 1997.

B.S., Civil Engineering, UCLA (University of California, Los Angeles) - 1989.

ADDITIONAL SKILLS

- Registered Professional Engineer (Civil), California, Utah.
- Over 100 hours of health and safety training in the petrochemical and construction industries, including 40-Hour Hazardous Waste Operations Worker (HAZWOPER) certification.
- Presented papers at numerous peer-reviewed technical conferences.

KARAN GIRISH MEHTA

B/3, SURAJ SADAN, N. S. RD NO 3, JUHU SCHEME, VILE PARLE (W), MUMBAI-400056.

Tel: +91-9820619396/+13852720685; Email: k_g_mehta@hotmail.com

Objectives

To apply and continue to develop my technical, analytical expertise and skills in the environmental engineering.

Experience

OVIVO USA LLC, SALT LAKE CITY, UTAH (UNITED STATES OF AMERICA)

Date of Employment : October 2016 to present

Product Manager – Process, Engineering and Sales

- Work with Ovivo corporate sales and engineering staff, outside sales representatives, consulting engineers, treatment plant operators and government officials to design treatment systems to meet the specific objectives of their facility.
- Technical proficiencies include process design of three biological treatment systems (Cleartec® / AeroStrip® / Carrousel®) and a variety of unit processes. These processes include biological, chemical and mechanical functions.
- Evaluate design inquiries and prepare detailed designs of mechanical and diffused aeration systems. Balance specific project drivers such as: project economics, site limitations, energy efficiency, and equipment installation labor as well as system maintenance requirements.
- Conduct process start up services on mechanical equipment, electrical components and biological processes at treatment plants across North America.
- Communicate regularly with installing contractors and plant operations and maintenance staff.
- Solve field installation / construction issues.
- Evaluate and remediate mechanical and electrical component matters. Evaluate and solve process challenges during start up as well as at existing operating facilities.
- Prepare process designs and technical proposals.
- Travel on demand to project sites, treatment plants and engineer's offices across North America.
- Make technical presentations to Engineers, Owners, professional organizations and government agencies.
- Responsible for the design of secondary clarifiers based on state-point analysis.
- Competent in the use of Bio-Win activated sludge monitoring software.
- Prepare detailed cost estimates for wastewater treatment plant equipment and piping systems.
- Prepare system specifications for the AeroStrip, Carrousel and IFAS systems.
- Create layout drawings for AeroStrip, Carrousel and IFAS systems in AUTOCAD.
- Review technical research work and summarize for use by the sales, marketing and engineering departments.
- Fluent in English with strong verbal and written communication skills in each language.
- Ability to travel and work in both office and field (wastewater plant) environments.

OVIVO INDIA PVT LTD, INDIA. SURAT, GUJARAT (INDIA)

Date of Employment : July 2012 to October 2016

Application Specialist – Process, Engineering and Sales

- Engineer and design all system components, complete process unit sizing, for technologies based on activated sludge process and attached growth system. These systems are developed based on detailed cost estimates of each component, in view of balancing economic and efficiency.
- Deep knowledge of OVIVO's products such as Cleartec® / AeroStrip® / Carrousel® and competitive technologies, work as advisor to the USA team.

- Responsible for detailed design, start-up and support for Ovivo of Aerostrip® Aeration systems, Cleartec® Systems, and Carrousel® Systems in North America.
- Post-order preparing of process design sheet, final cost estimation sheet, design and guarantee parameters, scope of supply, P& ID, Layout and Hydraulic Flow Diagram.
- Designed and commissioned textile-based integrated fixed film activated sludge systems for activated sludge wastewater applications based on influent process parameters and effluent requirements.
- Designed of strip polyurethane ultra-fine pore aeration systems and their effects on textile-based IFAS media in activated sludge wastewater applications.
- Provided technical support to the North American Aeration Process Group.
- Expertise in designing mechanical aeration systems, specifically the Carrousel® process.
- Expertise in clarifier design based on state-point analysis.
- Competency in Bio-Win activated sludge monitoring software.
- Competency in detailed cost estimating for wastewater treatment plant equipment and pipework.
- Expertise in designing biological nutrient removal (BNR) processes.
- Expertise in generating and evaluating system specifications for Aerostrip, Carrousel and IFAS.
- Ability to generate 2D layout drawings for Aerostrip, Carrousel and IFAS systems.
- Ability to review and summarize technical research work done in wastewater treatment around the world.
- Fluency in English, with strong verbal and written communication skills.
- Ability to travel and work in both office and wastewater plant environments.

A.T.E. ENVIROTECH PVT LTD - MUMBAI, INDIA.

Dates of Employment: October 2010 to July 2012

Project Engineer

- Handled projects for Waste Water Treatment (ETP, UF, RO and Softening plants) including detailed design, piping layout and system pricing. Additionally prepared P&ID, equipment layout drawings, vessel design as well as civil drawings (HFD and puddle piping).
- Responsible for planning projects on Microsoft Project and coordinating all project related activities including design, engineering, procurement, dispatch, commissioning and testing with clients and vendors.
- Additionally handled proposal preparation and procurement.
- Worked as the internal auditor for ISO Audit.

Academic Project:

2009-2010 D.J. Sanghvi College of Engineering; Mumbai, Maharashtra, India.

Manufacturing Of Butene-1

Designed a complete plant and process system for large scale manufacturing of Butene-1. This is a versatile chemical compound used in the production of low density polyethylene (LDPE), high density polyethylene (HDPE) as a copolymer that uses dimerization of ethylene under pressure followed by the distillation process along with detailed Equipment design, Cost and Feasibility analysis for the selected site (in Gujarat, India).

Technical Skills

- Basic knowledge of Chemical Process Technology, Water and Wastewater Technology, Biological Waste water Technology, IFAS Technology, Petrochemical production, Material Operations, Mass Transfer, Heat Transfer, Energy Engineering, Plant utility, Environmental Engineering, Chemical Reaction Engineering, Simulation and more.

Soft Skills

- Hands on experience on live projects in Excel Programming and Microsoft Projects.
- Hands on experience on chemical industry related software including CHEMCAD, AutoCAD and Bio-win (Enviro-Sim).
- Hands on experience on programming Languages C and C++.

Achievements and Hobbies

- Event Management for ROMAN NAVRATRI UTSAV-2010.
- Volunteer (IChE) in college technical and cultural festivals.
- Participated in various social services like NASEO and social activities.
- Hobbies – Reading, Music, Surfing.

Education

Bachelor of Engineering (Chemical) - 2010

SVKM's Dwarkadas J. Sanghvi College of Engineering. (Mumbai University), Mumbai, India.

H.S.C.- 2006

SVKM's A.V.PATEL JR COLLEGE of Science Mumbai, Maharashtra, India.

I.C.S.E- 2004

JAMNABAI NARSEE SCHOOL Mumbai, Maharashtra, India.

Personal Details

Date Of Birth: 7/13/1988
Languages Known: English, Hindi, and Marathi
Marital Status: Single
Current Address: 762 W Sunny River Road, apt 1525, Taylorsville, Utah 84123

References

References are available on request.

Declaration

I do hereby declare that the particulars of information and facts stated herein above are true, correct and complete to the best of my knowledge and belief.

PLACE: SALT LAKE CITY

KARAN GIRISH MEHTA

00 61 13 PERFORMANCE BOND

<p>Seller as Principal</p> <p>Name:</p> <p>Mailing address (principal place of business):</p>	<p>Surety</p> <p>Name:</p> <p>Mailing address (principal place of business):</p>
<p>Buyer</p> <p>Name: City of Pflugerville, Texas</p> <p>Mailing address (principal place of business):</p> <p>PO Box 589 Pflugerville, TX 78691-0589</p>	<p>Physical address (principal place of business):</p> <p>Telephone (Main):</p> <p>Telephone (Claims):</p>
<p>Procurement Contract</p> <p>Project name and number:</p> <p>Central WWTP Expansion BNR Process Equipment PFL16607</p> <p>Procurement Contract Price: Effective Date of Procurement Contract:</p>	<p>Surety's state of incorporation:</p> <p><i>By submitting this bond, Surety affirms that it is licensed to provide and execute this bond and authorized to do business in the state of Texas.</i></p> <p>Local Agent for Surety</p> <p>Name:</p> <p>Mailing address (principal place of business):</p>
<p>Bond</p> <p>Bond Amount: 100 percent of Procurement Contract Price</p> <p>Date of Bond:</p> <p>(Date of Bond cannot be earlier than Effective Date of Procurement Contract)</p>	<p>Telephone (Main):</p> <p><i>The address of the surety company to which any notice of claim should be sent may be obtained from the Texas Dept. of Insurance by calling the following toll-free number: 1-800-252-3439.</i></p>

Surety and Seller, intending to be legally bound and obligated to Buyer do each cause this performance bond to be duly executed on its behalf by its authorized officer, agent, or representative. The Seller and Surety bind themselves, and their heirs, administrators, executors, successors and assigns, jointly and severally to this bond. The condition of this obligation is such that if the Seller as Principal faithfully performs the work required by the Procurement Contract then this obligation will be null and void; otherwise the obligation is to remain in full force and effect. Provisions of this bond are pursuant to the terms and provisions of Chapter 2253 and Chapter 2269 of the Texas Government Code as amended and all liabilities on this bond will be determined in accordance with the provisions of said Chapter to the same extent as if it were copied at length herein. Venue lies exclusively in Travis County, Texas for any legal action.

Seller as Principal

Signature: _____

Name: _____

Title: _____

Email: _____

Surety

Signature: _____

Name: _____

Title: _____

Email: _____

(Attach Power of Attorney and place surety seal below)

END OF SECTION

00 61 16 PAYMENT BOND

<p>Seller as Principal</p> <p>Name:</p> <p>Mailing address (principal place of business):</p>	<p>Surety</p> <p>Name:</p> <p>Mailing address (principal place of business):</p>
<p>Buyer</p> <p>Name: City of Pflugerville, Texas</p> <p>Mailing address (principal place of business):</p> <p>PO Box 589 Pflugerville, TX 78691-0589</p>	<p>Physical address (principal place of business):</p> <p>Telephone (Main):</p> <p>Telephone (Claims):</p>
<p>Procurement Contract</p> <p>Project name and number:</p> <p>Central WWTP Expansion BNR Process Equipment PFL16607</p> <p>Procurement Contract Price: Effective Date of Procurement Contract:</p>	<p>Surety's state of incorporation:</p> <p><i>By submitting this bond, Surety affirms that it is licensed to provide and execute this bond and authorized to do business in the state of Texas.</i></p> <p>Local Agent for Surety</p> <p>Name:</p> <p>Mailing address (principal place of business):</p>
<p>Bond</p> <p>Bond Amount:</p> <p>Date of Bond:</p> <p>(Date of Bond cannot be earlier than Effective Date of Procurement Contract)</p>	<p>Telephone (Main):</p> <p><i>The address of the surety company to which any notice of claim should be sent may be obtained from the Texas Dept. of Insurance by calling the following toll-free number: 1-800-252-3439.</i></p>

Surety and Seller, intending to be legally bound and obligated to Buyer do each cause this payment bond to be duly executed on its behalf by its authorized officer, agent, or representative. The Seller and Surety bind themselves, and their heirs, administrators, executors, successors and assigns, jointly and severally to this bond. The condition of this obligation is such that if the Seller as Principal pays all claimants providing labor or materials to Seller in the prosecution of the work required by the Procurement Contract then this obligation will be null and void; otherwise the obligation is to remain in full force and effect. Provisions of this bond are pursuant to the terms and provisions of Chapter 2253 and Chapter 2269 of the Texas Government Code as amended and all liabilities on this bond will be determined in accordance with the provisions of said Chapter to the same extent as if it were copied at length herein. Venue lies exclusively in Travis County, Texas for any legal action.

Seller as Principal

Signature: _____
 Name: _____
 Title: _____
 Email: _____

Surety

Signature: _____
 Name: _____
 Title: _____
 Email: _____

(Attach Power of Attorney and place surety seal below)

END OF SECTION