

PFLUGERVILLE ATHLETIC FEASIBILITY REPORT



Parkhill



where quality meets life

**PFLUGERVILLE
TEXAS**

TABLE OF CONTENTS

- 01 Executive Summary** **03**
- 02 Scope of Work** **04**
- 03 Need for Facilities** **05**
- 04 NRPA Report/Study** **06**
- 05 Population Growth/Age Groups** **08**
- 06 Facility & Park Locations** **09**
- 07 Projected Facilities** **10**
- 08 Public Engagement** **21**
- 09 Estimated Acreage & Pricing** **22**
- 10 Parcel/Acreage Suitability** **28**
- 11 Appendix** **30**

A - 31
 B - 33
 C - 43
 D - 54

Executive Summary

The tables below provide an overview of the feasibility report's key findings. It highlights the substantial shortage of outdoor recreational amenities based on the National Recreation and Park Association (NRPA) standards. The information presented is intended to give readers a clear, concise understanding of the project's outcomes before reviewing the detailed content of the full report.

	City	NRPA Standard 2025 Population	2025 NRPA Deficit (City)	2030 NRPA Deficit (City)	2035 NRPA Deficit (City)	2040 NRPA Deficit (City)	2045 NRPA Deficit (City)
Softball	1	15	14	16	18	19	21
		Acres	31.08	35.52	39.96	42.18	46.62

2.22 Acres Per Field with Buffer and Parking

	City	NRPA Standard 2025 Population	2025 NRPA Deficit (City)	2030 NRPA Deficit (City)	2035 NRPA Deficit (City)	2040 NRPA Deficit (City)	2045 NRPA Deficit (City)
Baseball	2	15	13	15	17	18	20
		Acres	41.86	48.3	54.74	57.96	64.4

3.22 Acres Per Field with Buffer and Parking

	City	NRPA Standard 2025 Population	2025 NRPA Deficit (City)	2030 NRPA Deficit (City)	2035 NRPA Deficit (City)	2040 NRPA Deficit (City)	2045 NRPA Deficit (City)
Tennis	1	11	10	12	14	15	16
		Acres	2.3	2.76	3.22	3.45	3.68

.23 Acres Per Court with Buffer and Parking

	City	NRPA Standard 2025 Population	2025 NRPA Deficit (City)	2030 NRPA Deficit (City)	2035 NRPA Deficit (City)	2040 NRPA Deficit (City)	2045 NRPA Deficit (City)
Rectangular Fields	7	14	7	10	11	13	14
		Acres	16.94	24.2	26.62	31.46	33.88

2.42 Acres Per Field with Buffer and Parking

	City	NRPA Standard 2025 Population	2025 NRPA Deficit (City)	2030 NRPA Deficit (City)	2035 NRPA Deficit (City)	2040 NRPA Deficit (City)	2045 NRPA Deficit (City)
Pickleball Courts	4	8	4	5	6	7	8
		Acres	0.6	0.75	0.9	1.05	1.2

.15 Acres Per Court with Buffer and Parking

	City	NRPA Standard 2025 Population	2025 NRPA Deficit (City)	2030 NRPA Deficit (City)	2035 NRPA Deficit (City)	2040 NRPA Deficit (City)	2045 NRPA Deficit (City)
Soccer	13	14	1	4	5	7	8
		Acres	3.05	12.2	15.25	21.35	24.4

3.05 Acres Per 18U, 11 v 11 Field with Buffer and Parking

	City	NRPA Standard 2025 Population	2025 NRPA Deficit (City)	2030 NRPA Deficit (City)	2035 NRPA Deficit (City)	2040 NRPA Deficit (City)	2045 NRPA Deficit (City)
Disc Golf	1	1	0	0	1	1	1
		Acres	0	0	36.28	36.28	36.28

36.28 Acres Per Course with Parking

	City	NRPA Standard 2025 Population	2025 NRPA Deficit (City)	2030 NRPA Deficit (City)	2035 NRPA Deficit (City)	2040 NRPA Deficit (City)	2045 NRPA Deficit (City)
Skate Parks	1	1	0	0	0	1	1
		Acres	0	0	0	1.63	1.63

1.63 Acres Per Park with Buffer and Parking

	City	NRPA Standard 2025 Population	2025 NRPA Deficit (City)	2030 NRPA Deficit (City)	2035 NRPA Deficit (City)	2040 NRPA Deficit (City)	2045 NRPA Deficit (City)
Basketball	9	8	-1	0	1	2	3
		Acres	-0.38	0	0.38	0.76	1.14

.38 Acres Per Court with Buffer and Parking

	City	NRPA Standard 2025 Population	2025 NRPA Deficit (City)	2030 NRPA Deficit (City)	2035 NRPA Deficit (City)	2040 NRPA Deficit (City)	2045 NRPA Deficit (City)
Sand Volleyball	4	2	-2	-1	-1	-1	-1
		Acres	-0.56	-0.28	-0.28	-0.28	-0.28

.28 Acres Per Court with Buffer and Parking

Total Acres		94.89	123.45	177.07	195.84	212.95
-------------	--	-------	--------	--------	--------	--------

Scope of Work

This feasibility study included evaluating multi-use fields for football, soccer, cricket, baseball, softball, and other amenities taking into account appropriate field sizes for various age groups. Public engagement played a critical role in this process. Parkhill analyzed community feedback from the recently-completed public outreach efforts completed in the 2023 Parks, Recreation & Open Space Master Plan. Parkhill then conducted five additional stakeholder meetings to further assess community sentiment and specific concerns regarding the growing demand and lack of field-based facilities.

Following this, Parkhill developed a comprehensive Field Program outlining recommended facility types, sizes, and age group accommodations. This program was created in collaboration with city officials to prioritize field development based on agreed-upon criteria. A site suitability study was conducted, using GIS analysis to evaluate potential locations for new fields based on topography, transportation access, utility infrastructure, and equitable distribution across the city. The study resulted in a map and a list of recommended parcels, including existing city-owned land and potential properties for acquisition.

This feasibility study also includes an Opinion of Probable Construction Cost for each proposed facility and a total in five year increments starting in 2025. A cost-benefit analysis comparing natural grass and synthetic turf options, along with long-term operations and maintenance costs is included for order of magnitude considerations on field surfacing. These findings are projected in a 20-year Capital Improvement Plan that accounts for inflation and provides a roadmap for addressing the city's recreational field needs.

The project included key in-person meetings: a kickoff and inventory meeting, current field assessment tour, five stakeholder sessions, a presentation of draft recommendations, and a final presentation. Additional meetings were conducted virtually. The goal of this study is to equip the City of Pflugerville with the information and planning tools needed to systematically close the gap in athletic field availability and growing demand for these services.



Need for Facilities

The City of Pflugerville is currently experiencing a significant deficiency in athletic recreation fields, with only 33 acres available to meet an immediate 55 acre demand for athletic fields. To address this 22-acre shortfall, the City sought a feasibility study to assess existing facilities, evaluate current and projected demand, and identify immediate and long-term needs. The study serves as the basis for a 20-year Capital Improvement Program aimed at expanding and improving athletic field infrastructure to meet the needs of the rapidly growing city.



National Recreation and Park Association (NRPA) Report

The National Recreation and Park Association's 2025 Agency Performance Review provides nationwide benchmarks for park and recreation agencies. The data, drawn from over 900 agencies, helped offer a baseline for evaluating whether the Pflugerville parks system is providing enough sports facilities at the national standard. Figure 3 provides the median number of residents per facility based off of the City's population. This report guided this study to determine what facilities need to be provided in the future.

The table to the right is the NRPA's findings expressed as the percent of agencies with the specific amenity in their park and recreation system in the first column. The following seven columns represent a ratio of one facility type per population served based on national benchmarking. For example, 94% of all agencies surveyed provide playgrounds. The total average is one playground per 3,737 persons in a population served. For a city with a total population of 50,000 to 99,999, the national benchmark is one playground per 3,643 persons in the population served.

FIGURE 3: OUTDOOR PARK AND RECREATION FACILITIES BY PREVALENCE AND POPULATION PER FACILITY

Types of Facilities	Median Number of Residents per Facility							
	Percent of Agencies	Population of Jurisdiction						
		All Agencies	Less Than 20,000	20,000 to 49,999	50,000 to 99,999	100,000 to 249,999	250,000 to 499,999	500,000 or More
Playgrounds	94%	3,737	2,000	3,320	3,643	5,000	6,562	14,717
Basketball courts*	85%	8,500	4,479	8,000	8,447	9,742	13,614	22,351
Diamond fields	80%	4,749	1,958	3,408	4,560	6,821	8,581	14,729
Rectangular fields	77%	5,946	2,578	4,002	4,659	7,993	10,392	21,628
Tennis courts*	74%	6,794	3,500	6,284	5,818	8,587	10,162	15,185
Dog parks	70%	47,247	10,188	26,534	55,250	76,509	95,805	165,982
Community garden plots	54%	35,065	8,800	27,230	56,367	57,676	131,908	139,509
Swimming pools	49%	46,800	9,745	26,900	48,064	59,897	87,117	156,427
Skate parks	47%	55,772	10,776	35,000	61,384	109,934	166,245	298,172
Pickleball courts*	45%	10,419	3,483	7,333	8,592	19,822	33,600	68,894
Volleyball courts*	41%	26,904	7,057	16,487	29,214	39,166	42,314	85,672
Fitness zones+	39%	32,044	8,274	21,468	32,500	38,668	79,466	148,447
Multiuse courts^	38%	23,739	3,900	17,209	25,512	45,772	64,571	86,237
Splash pads+	38%	49,392	13,391	29,804	51,000	61,418	93,435	199,437
Multiuse racquet courts^	38%	16,776	4,659	12,984	13,339	32,239	48,898	47,410
Walking/Running tracks+	36%	17,724	6,129	21,217	19,700	38,029	39,593	70,897
Disc golf courses	35%	66,923	9,402	32,519	56,150	113,800	177,590	390,000
Driving range stations	31%	25,284	3,548	23,211	7,774	40,096	94,836	211,750
18-hole golf courses	31%	97,892	11,904	34,058	62,756	114,877	149,489	288,000
Synthetic fields+	17%	46,833	11,028	23,958	33,799	54,125	83,490	145,564
Ice rinks	17%	19,533	8,338	21,428	28,500	98,156	14,753	701,786
Nine-hole golf courses	16%	119,000	17,500	36,127	64,937	121,492	282,013	617,995
Overlay fields	14%	18,598	7,932	10,054	25,500	18,595	30,919	97,500
Waterparks	12%	82,108	17,125	34,275	64,304	147,662	263,210	445,888
Racquetball/Handball/Squash courts	9%	48,668	14,000	23,974	40,796	45,060	181,703	154,261

*Dedicated to a single sport (not multiuse). +Fitness zones/exercise stations; splashpads/spray grounds/spray showers; walking/running tracks/loops; synthetic rectangular fields. ^Multiuse courts: basketball, volleyball, etc.; multiuse racquet courts: tennis, pickleball, etc. (excluding racquetball/handball/squash courts).

NRPA Metrics Study

Parkhill conducted a study based on the National Recreation and Park Association (NRPA) standards and Pflugerville's projected population growth to show recreational facilities demand within the city. According to the study, Pflugerville faces a substantial shortage of outdoor recreational amenities, with the greatest demand for baseball fields, softball fields, tennis courts, pickleball courts, soccer fields, and rectangular fields.

NRPA Park Metrics

	Feature	2025 City Owned A	NRPA Standard (1 PER Group of Residents)	2025 Total Need (Pop. 66,819) B	2025 Deficit = B - A	2030 Total Projected Need (Est. Pop. 77,224) C	2030 Deficit = C - A	2035 Total Projected Need (Est. Pop. 84,652) D	2035 Deficit = D - A	2040 Total Projected Need (Est. Pop. 92,079) E	2040 Deficit = E - A	2045 Total Projected Need (Est. Pop. 99,507) F	2045 Deficit = F - A	
Outdoor	Basketball Court	9	8,447	8	-1	9	0	10	1	11	2	12	3	
	Baseball Field	2	4,560	15	13	17	15	19	17	20	18	22	20	
	Softball Field	1	4,560	15	14	17	16	19	18	20	19	22	21	
	Disc Golf Course	1	56,150	1	0	1	0	2	1	2	1	2	1	
	Football / Rugby / Lacrosse	7	4,659	14	7	17	10	18	11	20	13	21	14	
	Pickleball Court	4	8,592	8	4	9	5	10	6	11	7	12	8	
	Skate Park	1	61,384	1	0	1	0	1	0	2	1	2	1	
	Soccer Field	13	4,659	14	1	17	4	18	5	20	7	21	8	
	Tennis Court	1	5,818	11	10	13	12	15	14	16	15	17	16	
	Sand Volleyball Court	4	29,214	2	-2	3	-1	3	-1	3	-1	3	-1	
	Cricket Ground	0	No Official Standard											

Population Growth & Age Groups

The graph attached illustrates the population growth of Pflugerville, Leander, Georgetown, Round Rock, Hutto, Taylor, Cedar Park for the next 20 years. The bar charts show the current and projected growth of age groups for the next 10 years. Using the information, we were able to estimate the field sizes needed to support the growth of Pflugerville.

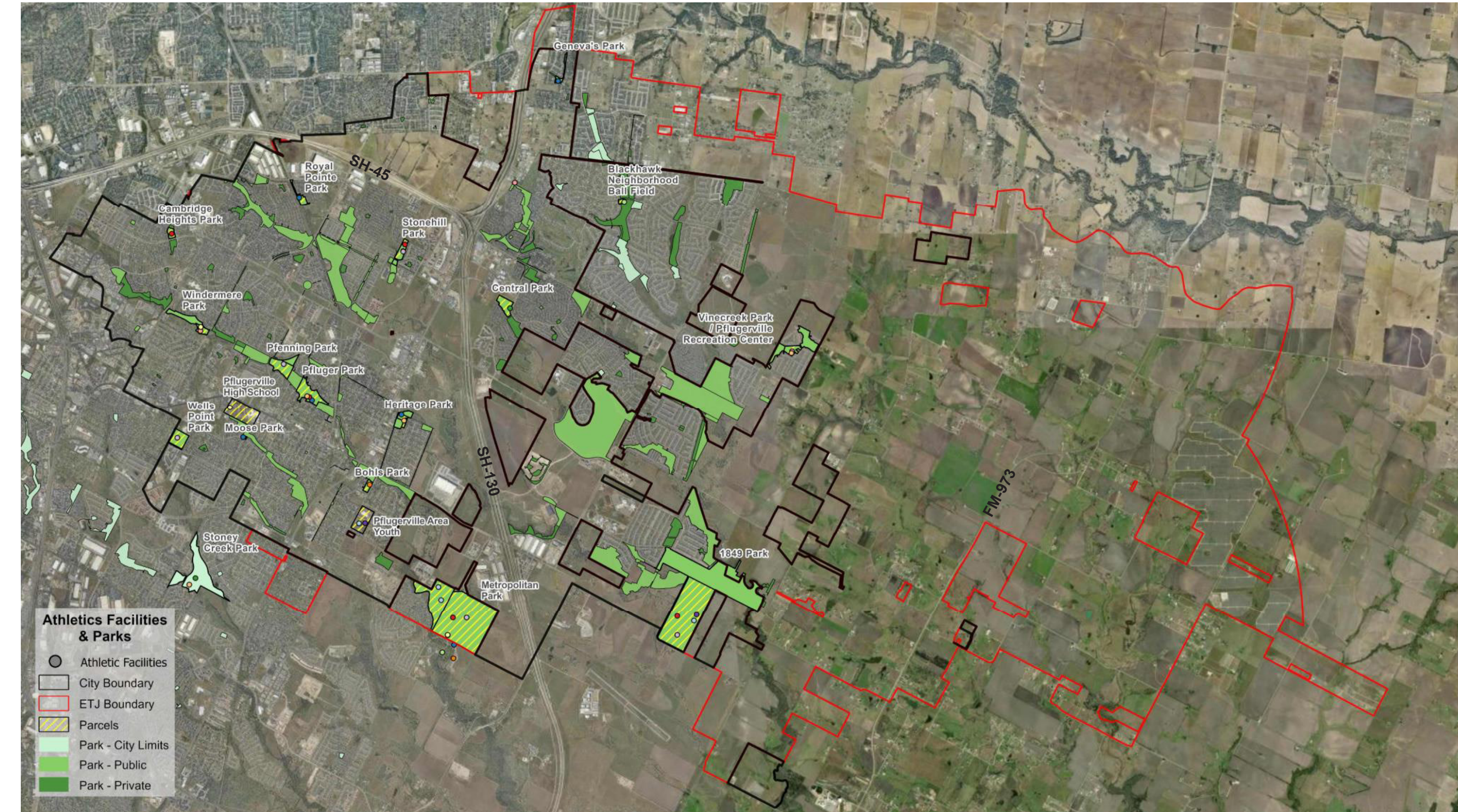
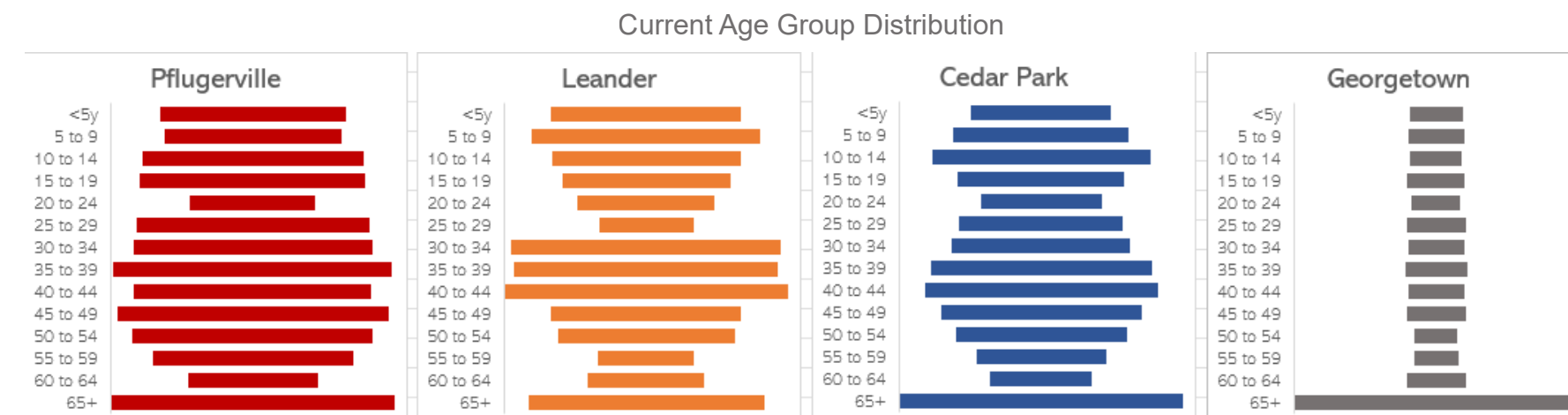
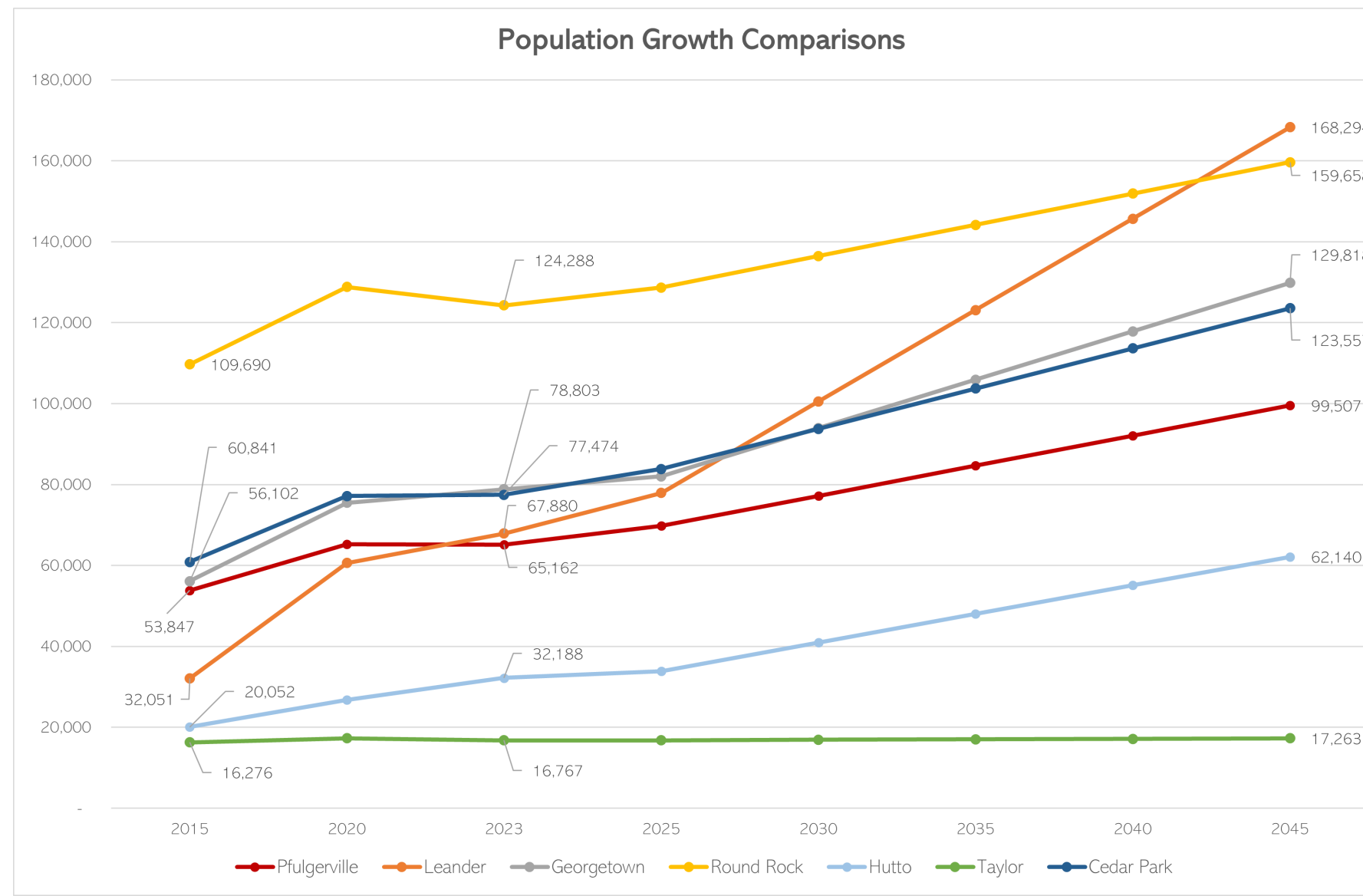
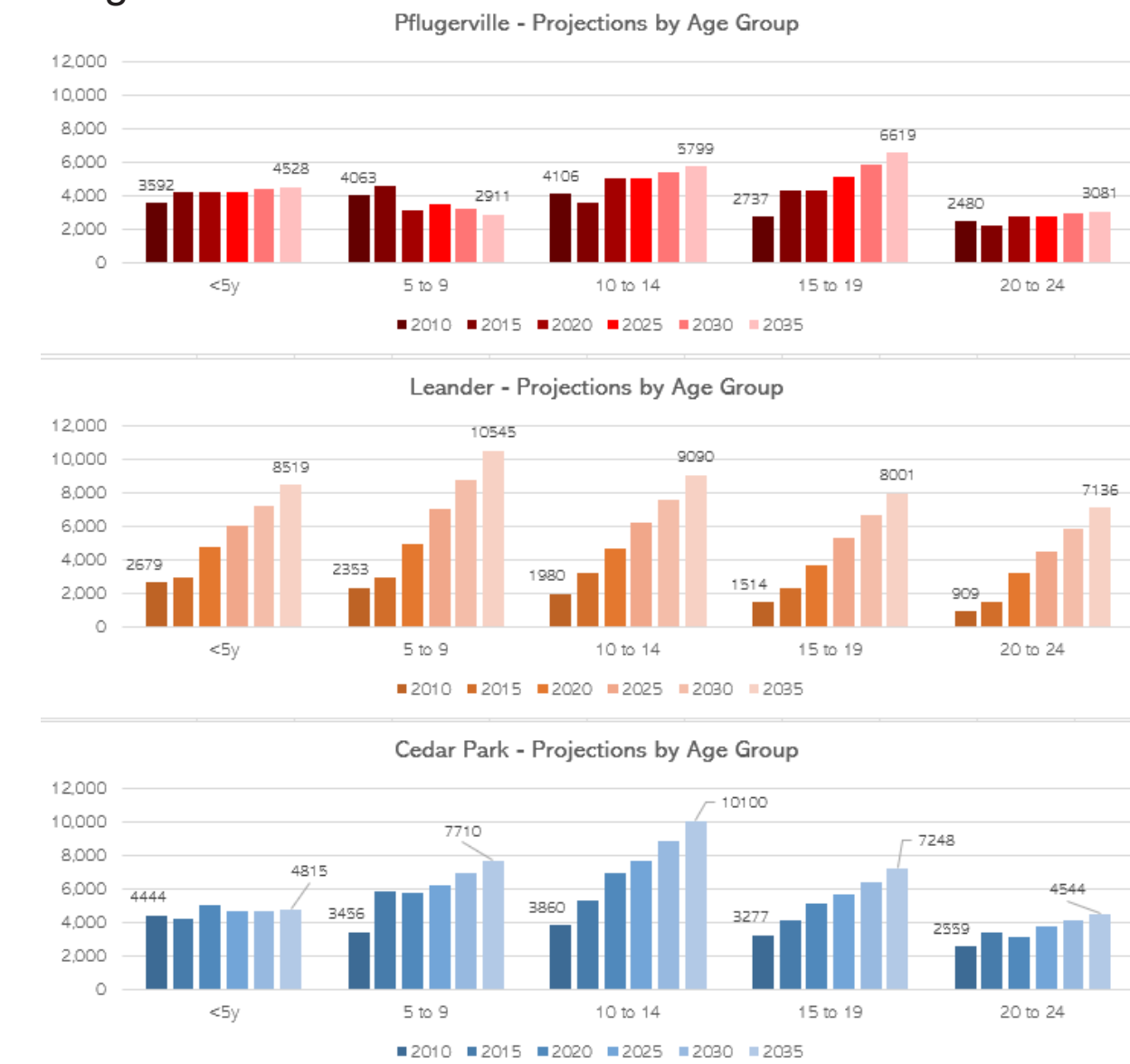

2025 Facility & Park Locations

*Reference Appendix C for enlarged facility & park locations

Projected Basketball Courts

NRPA Standards: 1 basketball court per group of 8,447 residents.

2025: The City's 2025 court inventory meets NRPA Standards, but court demand should be re-evaluated every 5 years as population and participation trends evolve.

Leagues and organizations who use facilities: Pflugerville Youth Basketball Association (PYBA)

Age levels who use facilities: 6-14 year olds

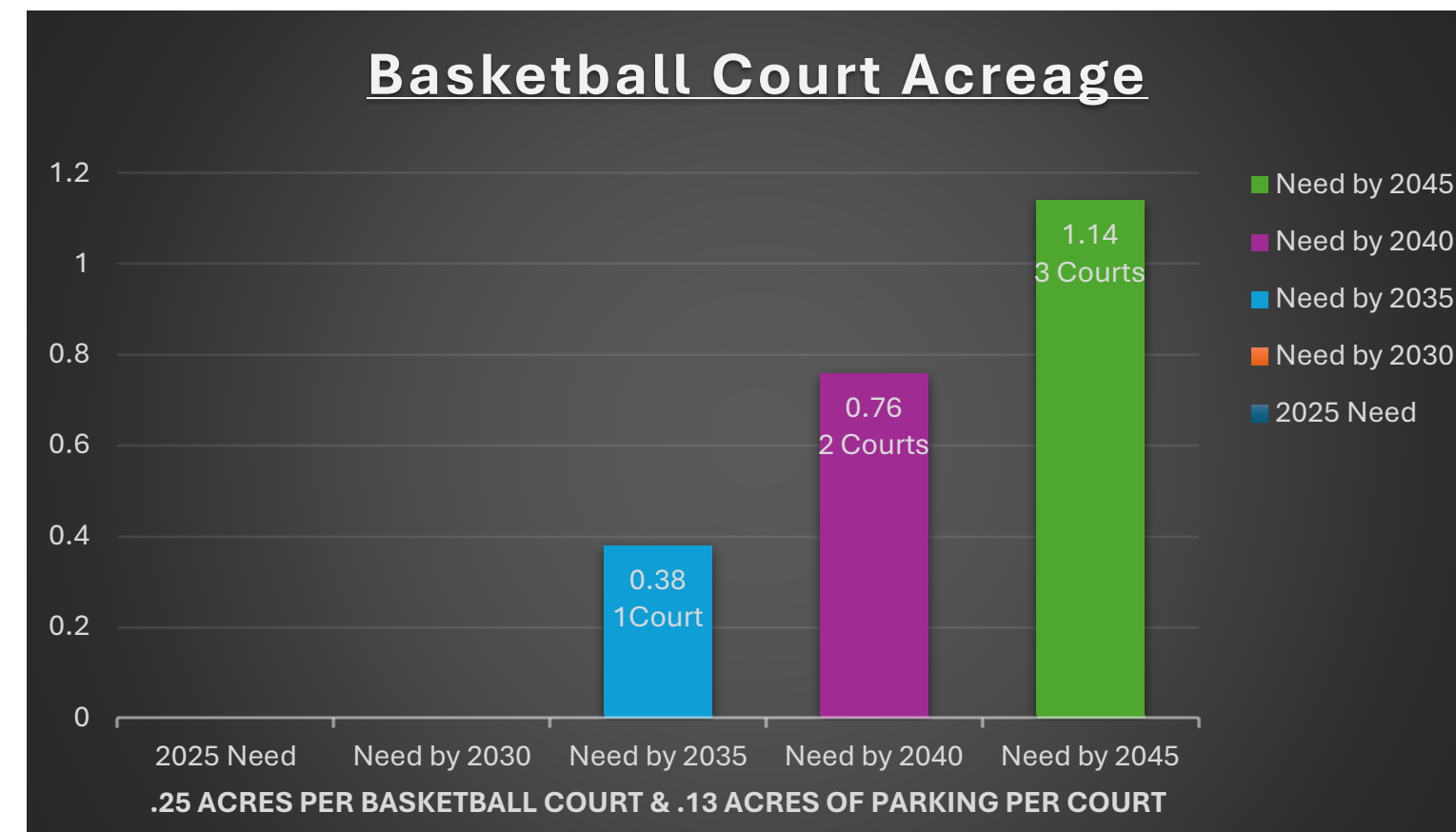
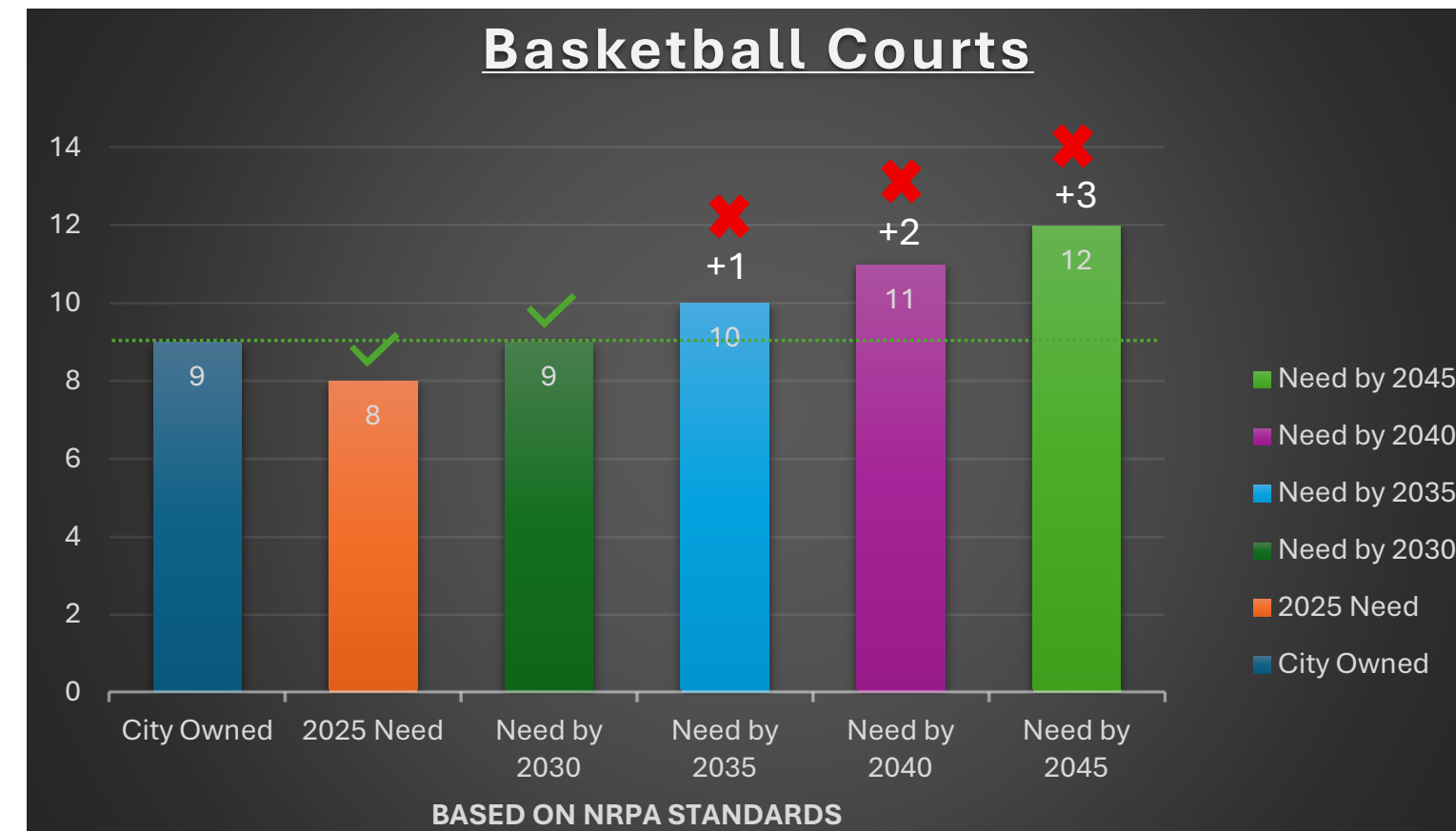
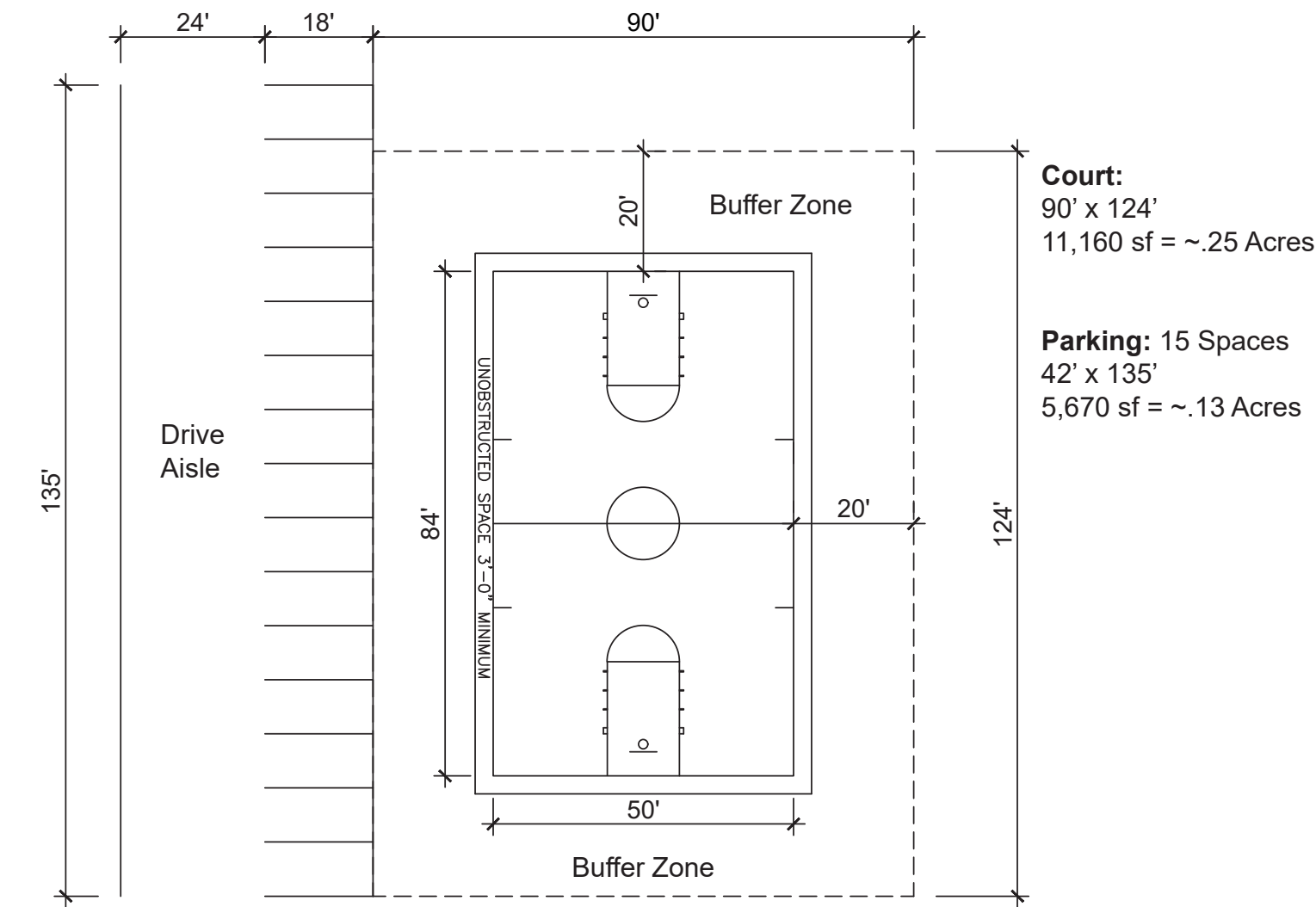

Projected Baseball Fields

NRPA Standards: 1 baseball field per group of 4,560 residents.

2025: The City's current field inventory is significantly lower than NRPA Standards for the 2025 population.

Leagues and organizations who use facilities: Pflugerville Area Youth Baseball And Softball (PAYBAS)

Age levels who use facilities: 4-14 year olds

PAYBAS away games travel distance:

- Pflugerville to Austin - 17.8 miles, 27 minutes
- Pflugerville to Hutto - 9.6 miles, 17 minutes
- Pflugerville to Lexington - 47.1 miles, 59 minutes
- Pflugerville to Manor - 11.7 miles, 18 minutes
- Pflugerville to Taylor - 18.1 miles, 29 minutes

*Reference Appendix C for Northeast Metropolitan Park Fees

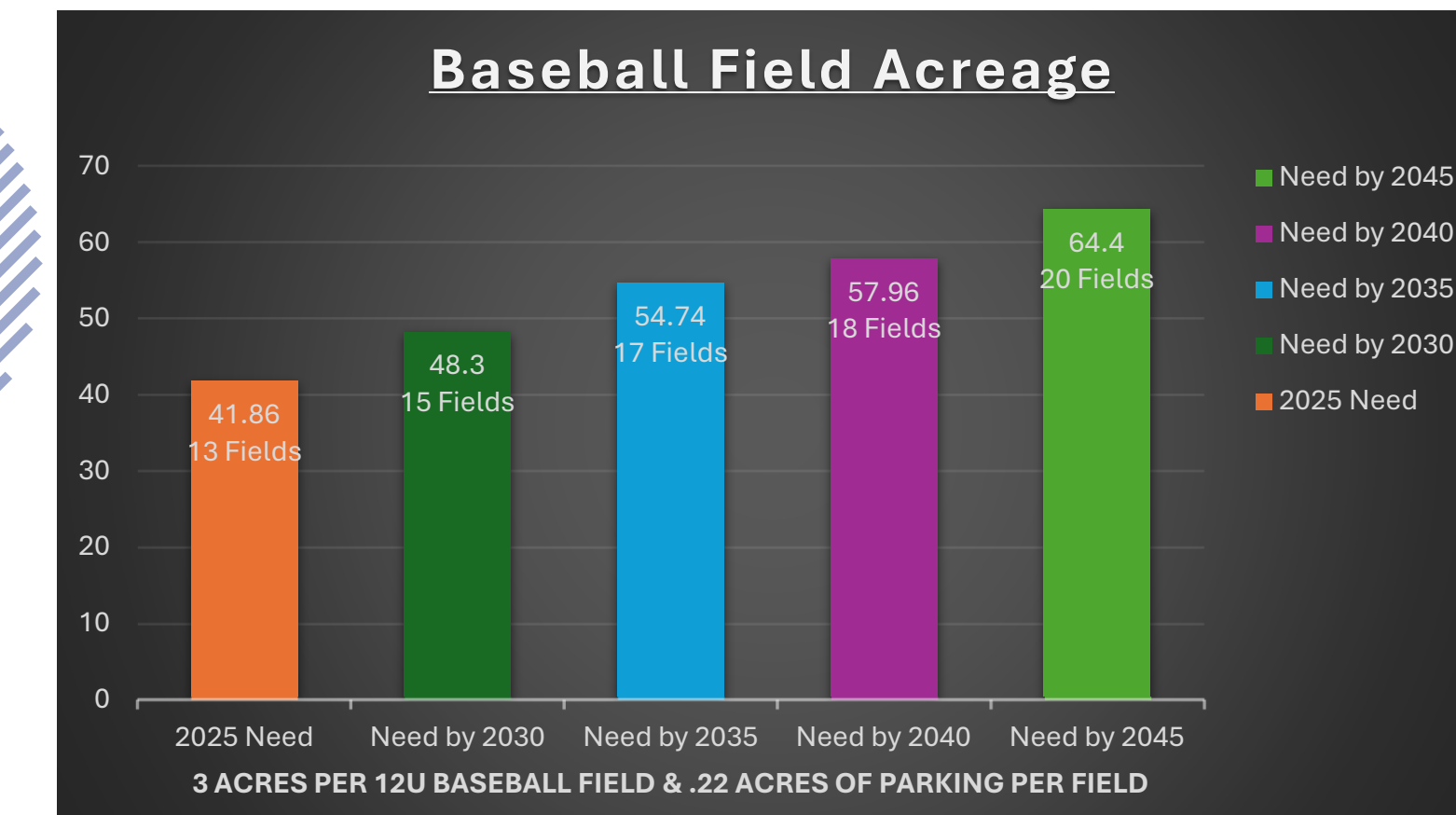
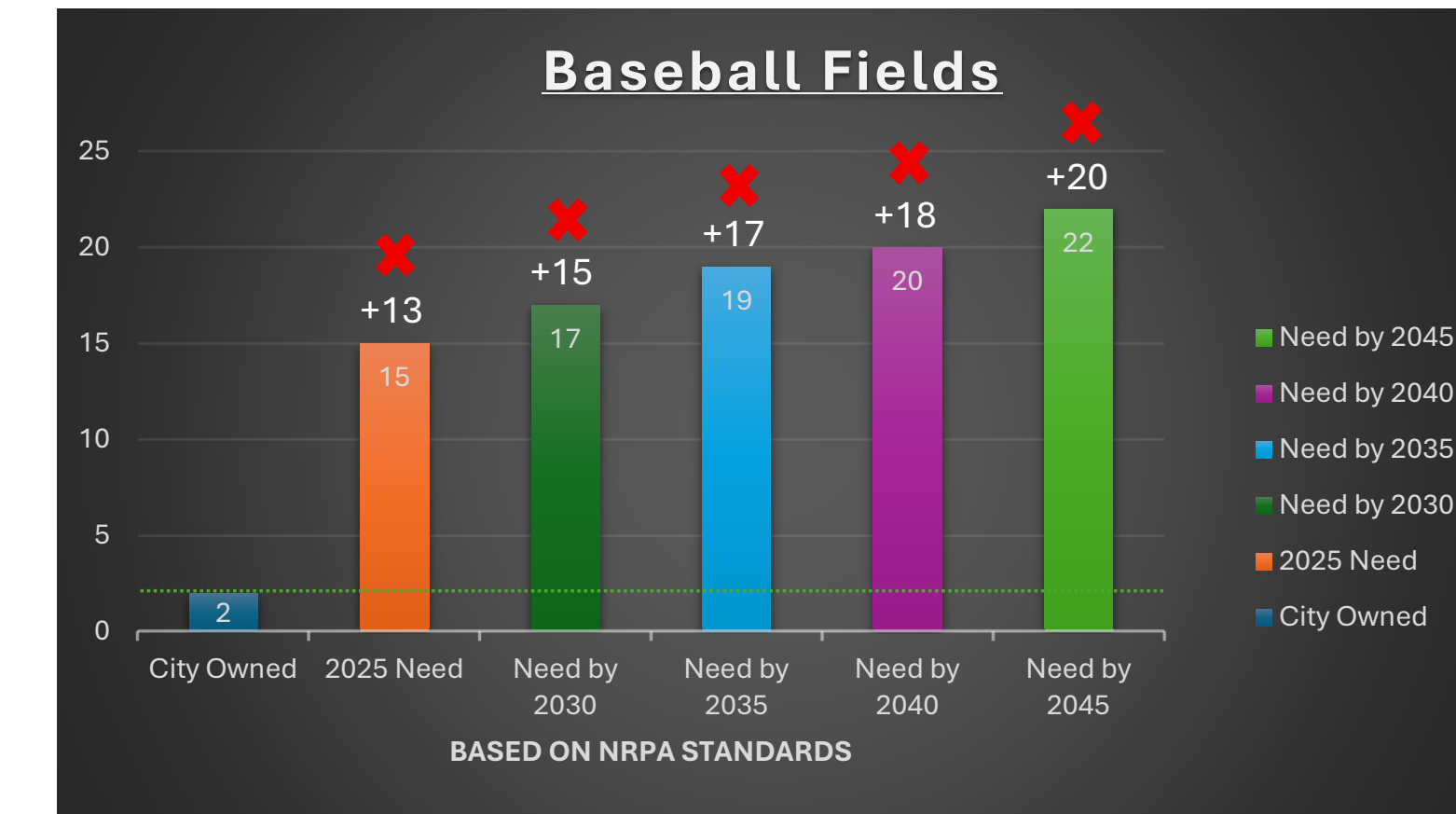
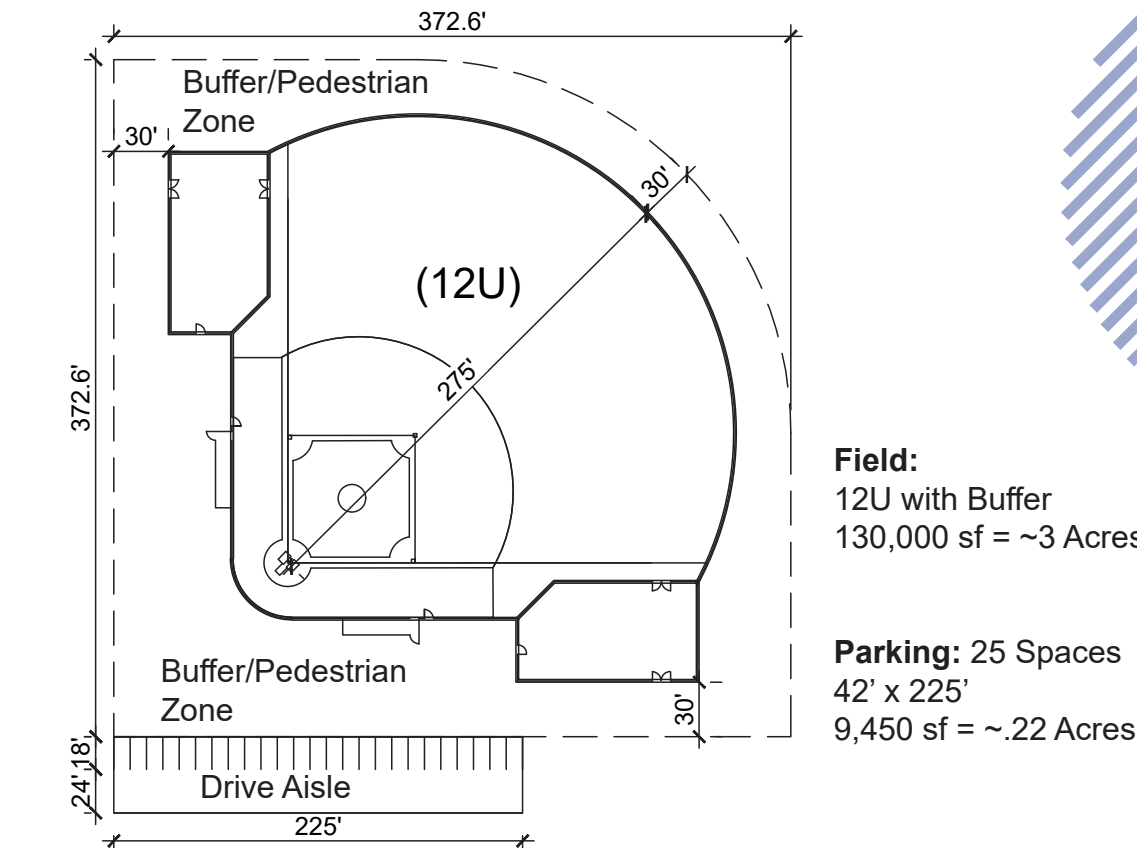

*Reference Appendix B for graphs including non-city owned facilities

*Reference Appendix B for graphs including non-city owned facilities

Projected Softball Fields

NRPA Standards: 1 softball field per group of 4,560 residents.

2025: The City's current field inventory is significantly lower than NRPA Standards for the 2025 population.

Leagues and organizations who use facilities: Pflugerville Area Youth Baseball And Softball (PAYBAS)

Age levels who use facilities: 4-14 year olds

PAYBAS away games travel distance:

- Pflugerville to Austin - 17.8 miles, 27 minutes
- Pflugerville to Hutto - 9.6 miles, 17 minutes
- Pflugerville to Taylor - 18.1 miles, 29 minutes
- Pflugerville to Cedar Park - 17.1 miles, 27 minutes

*Reference Appendix C for Northeast Metropolitan Park Fees

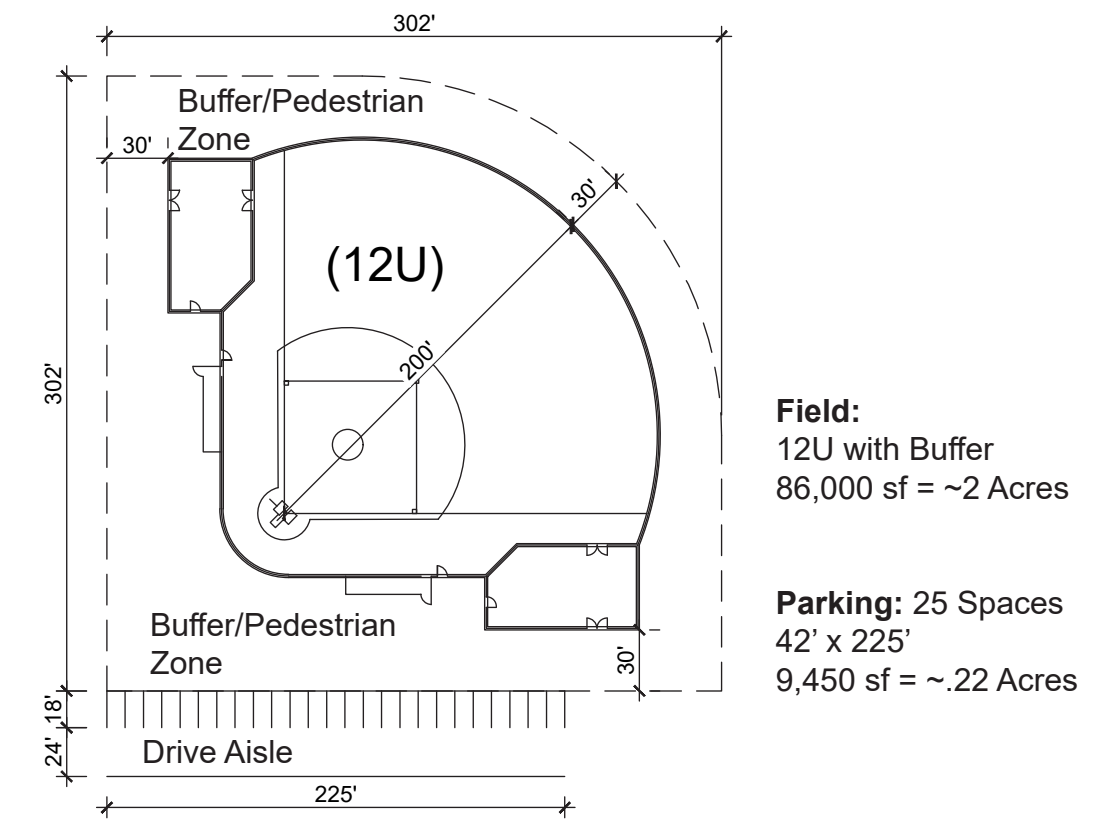

Field:
12U with Buffer
86,000 sf = ~2 Acres

Parking: 25 Spaces
42' x 225'
9,450 sf = ~.22 Acres

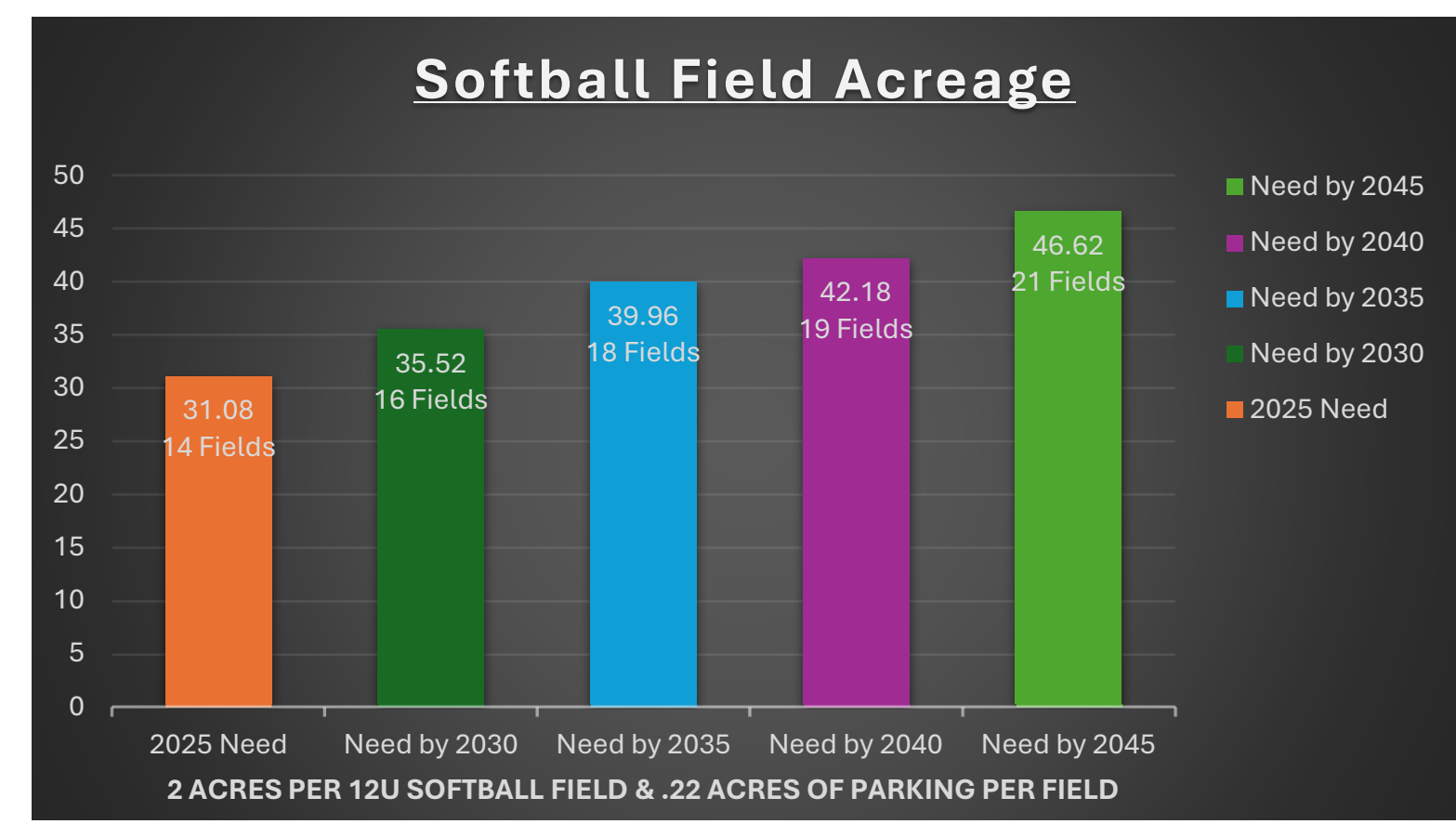
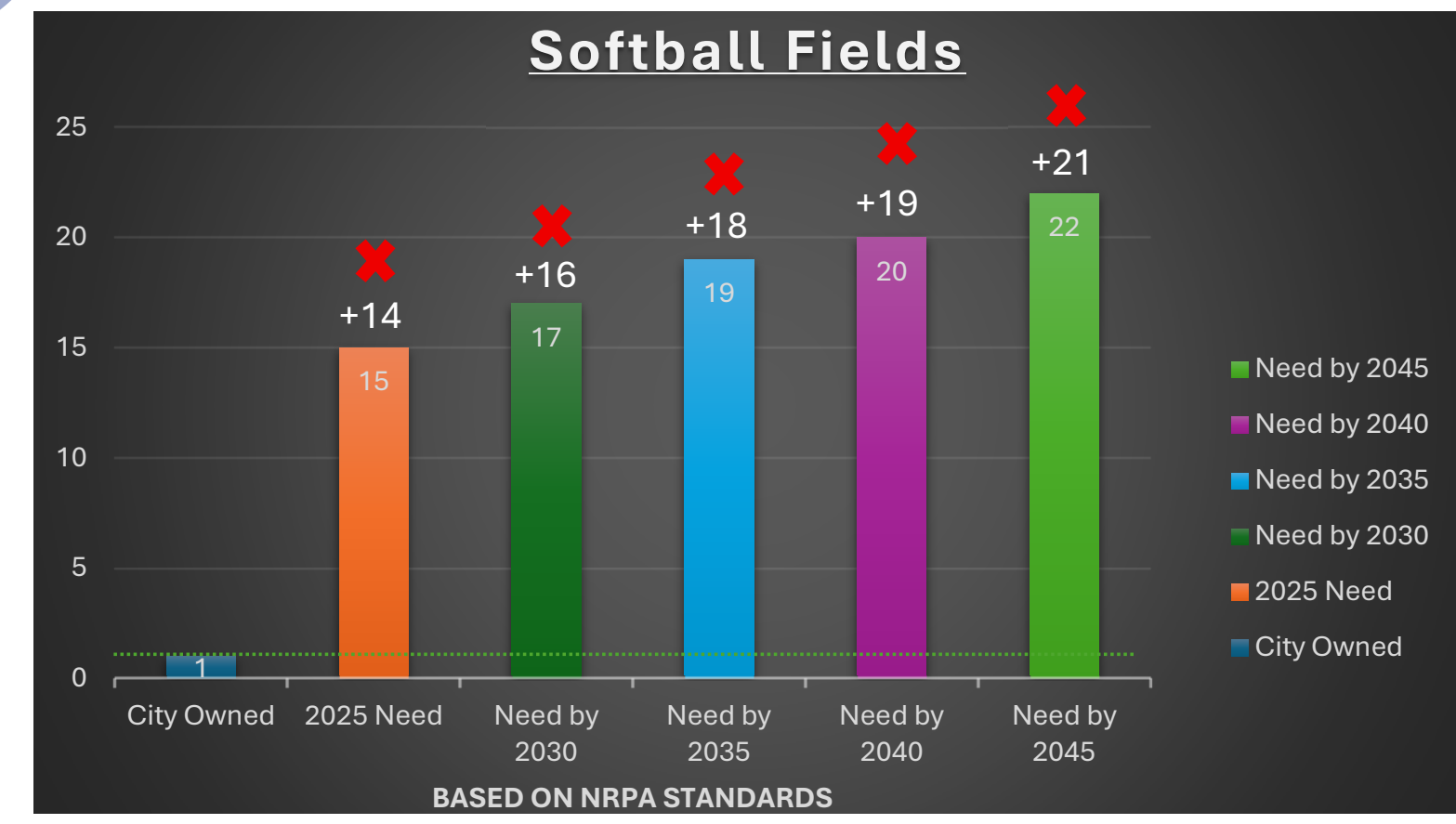

*Reference Appendix B for graphs including non-city owned facilities

Projected Disc Golf Courses

NRPA Standards: 1 disc golf course per group of 56,150 residents.

2025: The City's 2025 inventory meets NRPA Standards, but course demand should be re-evaluated every 5 years as population and participation trends evolve.

Leagues and organizations who use facilities: Professional Disc Golf Association (PDGA), Las Basuras, Turcotte's, TFG Disc Golf

Age levels who use facilities: All ages

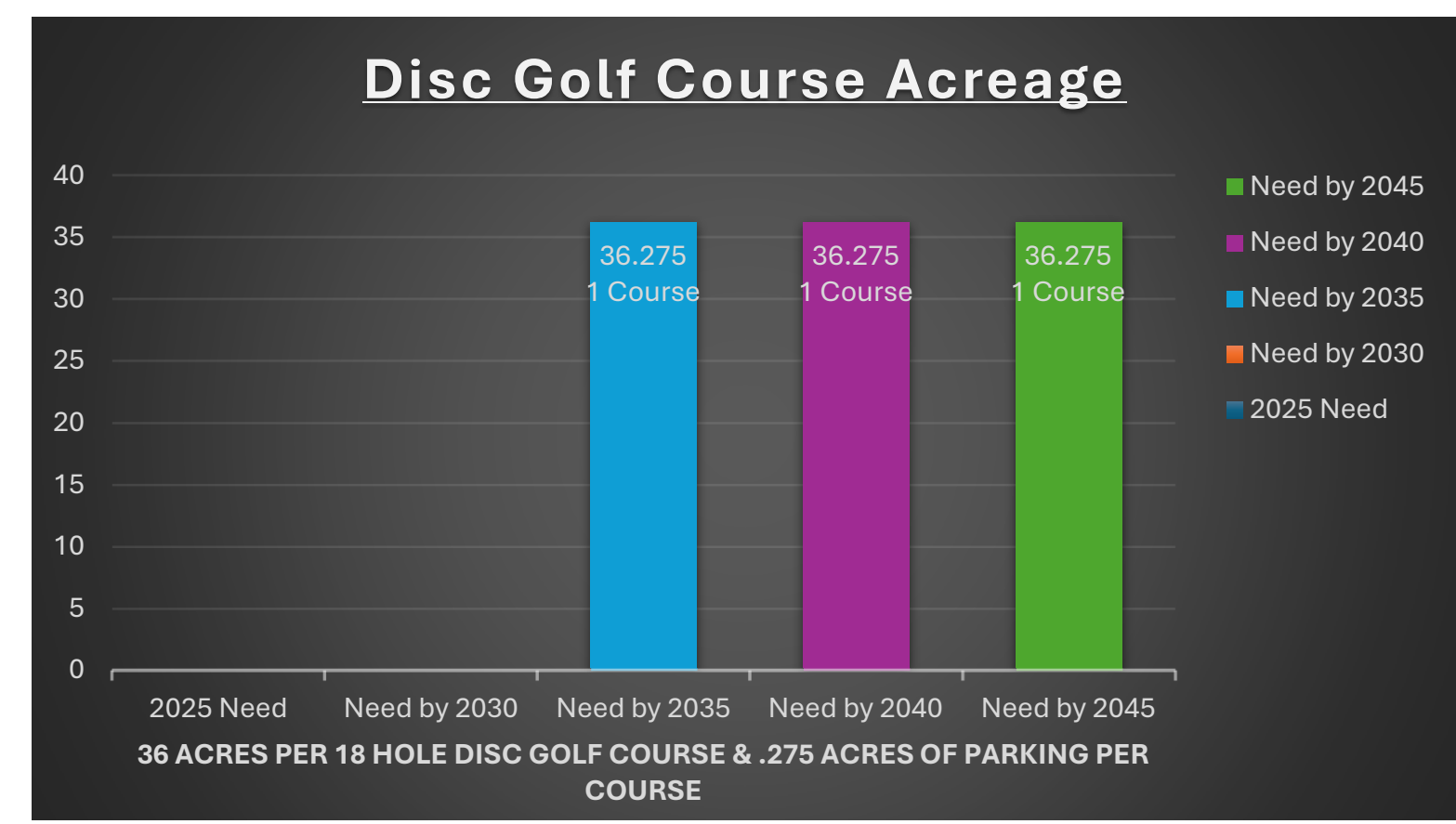
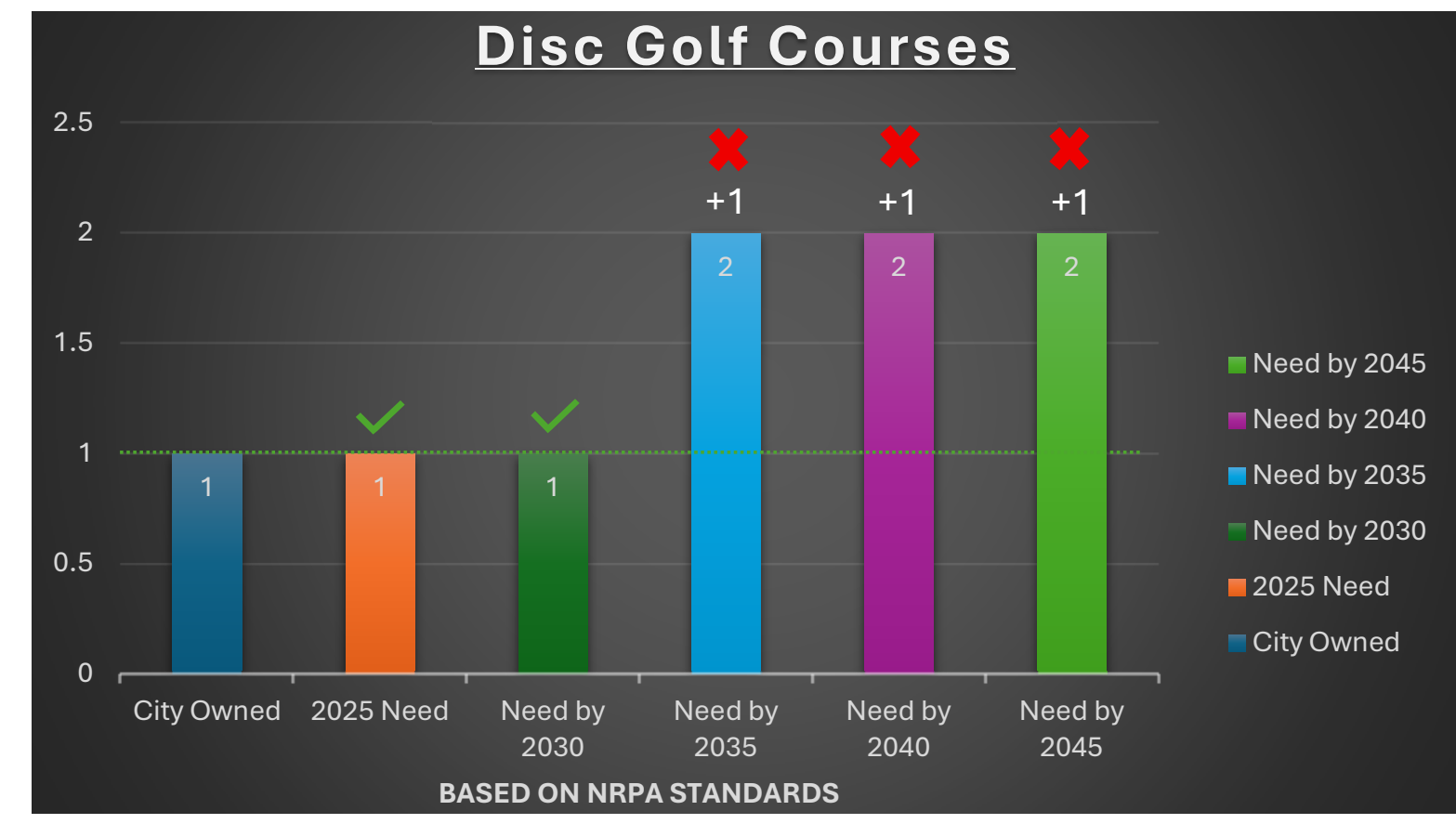

*Reference Appendix B for graphs including non-city owned facilities

Projected Rectangular Fields

NRPA Standards: 1 rectangular field per group of 4,659 residents.

2025: The City's current field inventory is significantly lower than NRPA Standards for the 2025 population.

Leagues and organizations who use facilities: Pflugerville Force Youth Football, i9 Sports (multi-sport), Austin Ultimate (Ultimate Frisbee)

Age levels who use facilities: All ages

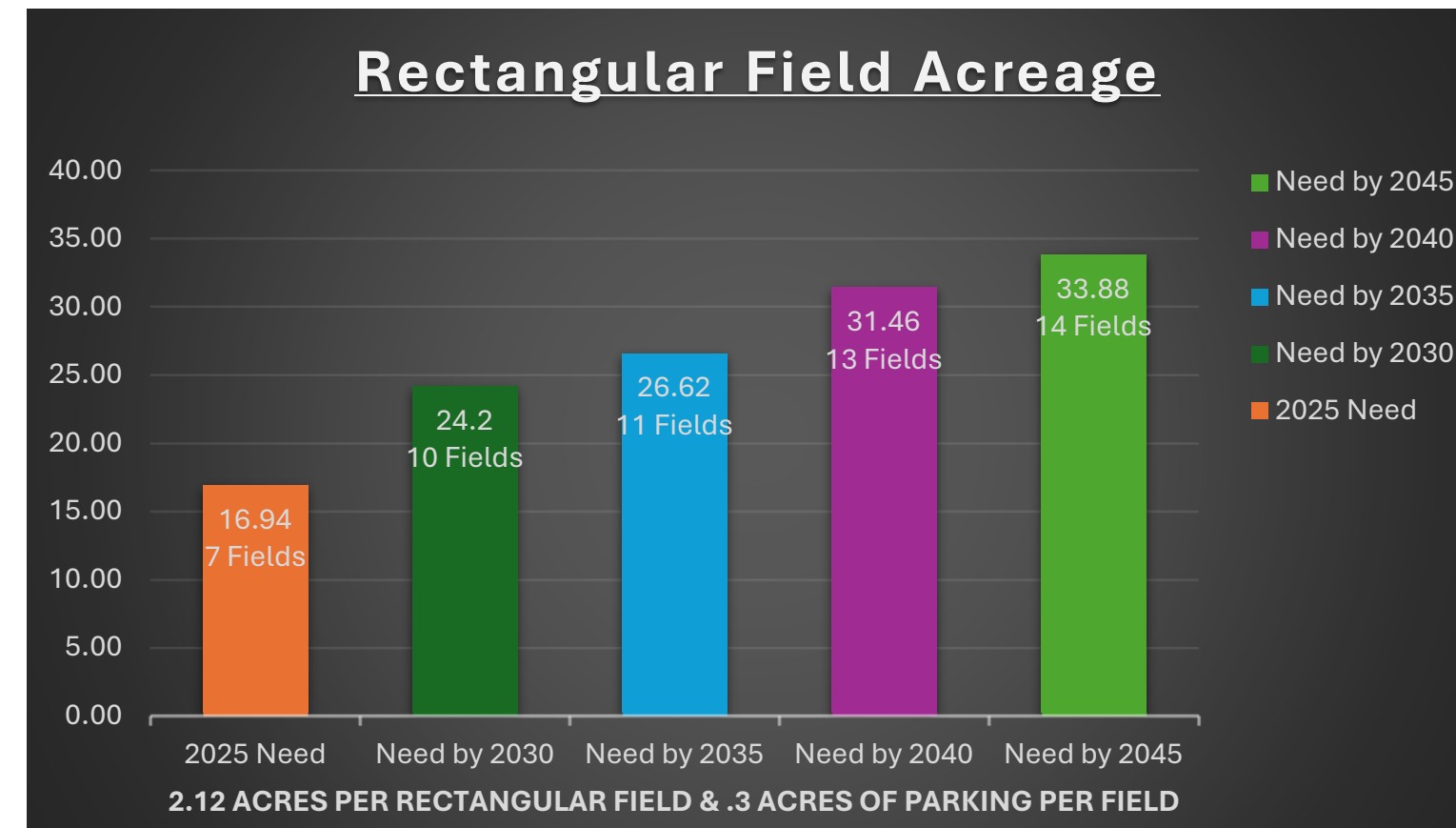
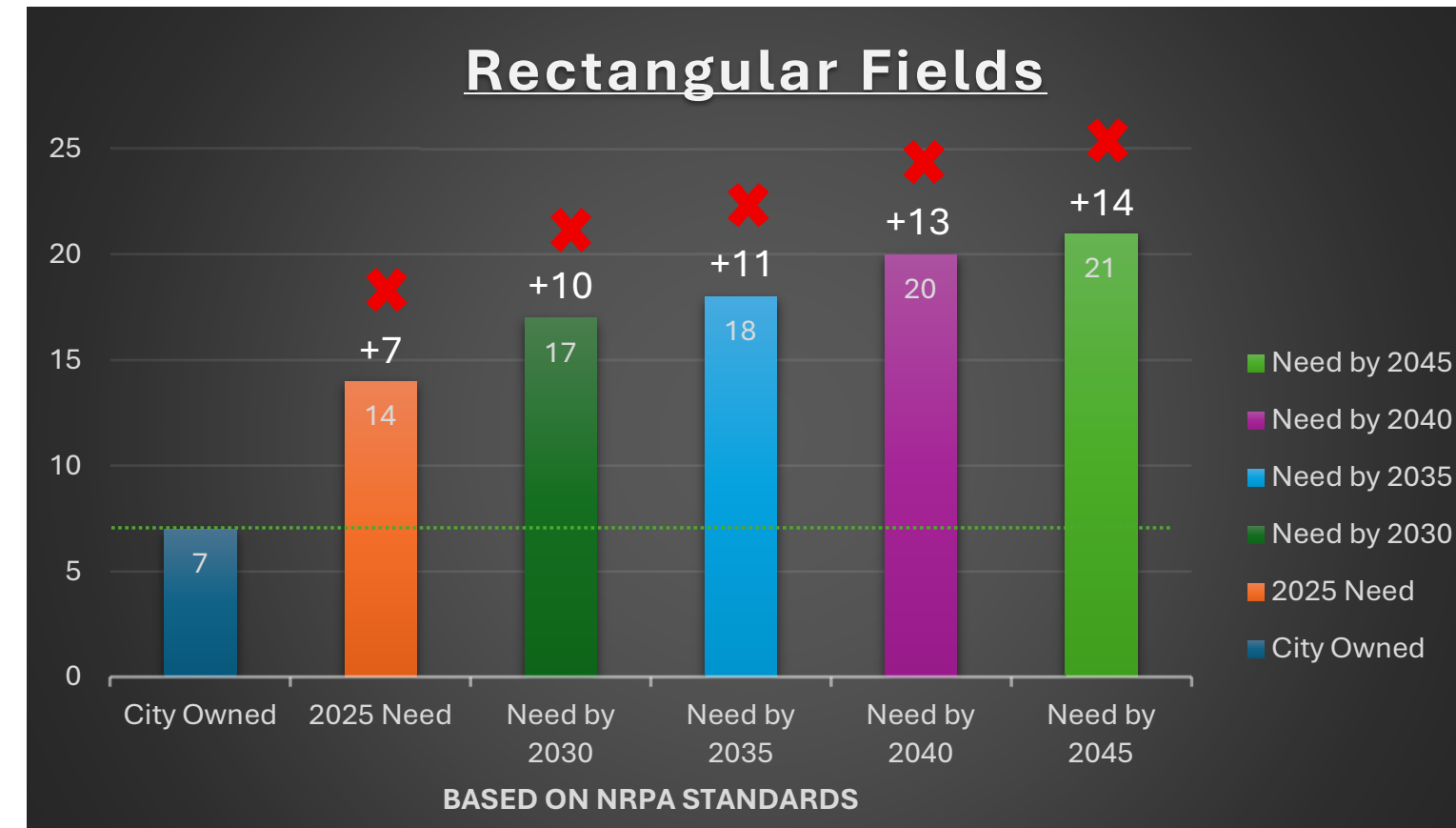
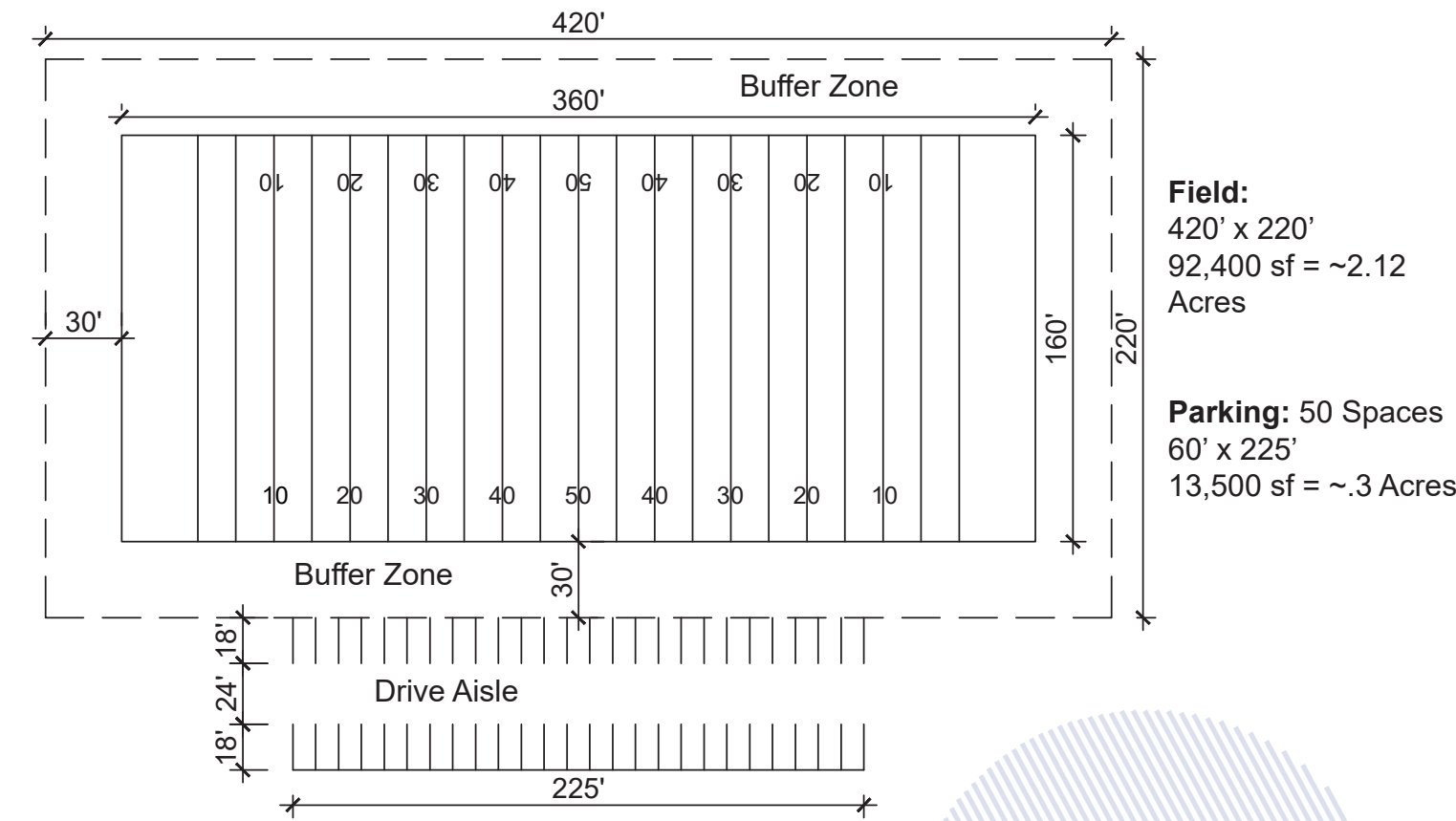

Projected Pickleball Courts

NRPA Standards: 1 pickleball court per group of 8,592 residents.

2025: The City's current court inventory does not meet NRPA Standards for the 2025 population.

Leagues and organizations who use facilities: Pickleheads, Pickleball Pflugerville, Ladder League

Age levels who use facilities: All ages

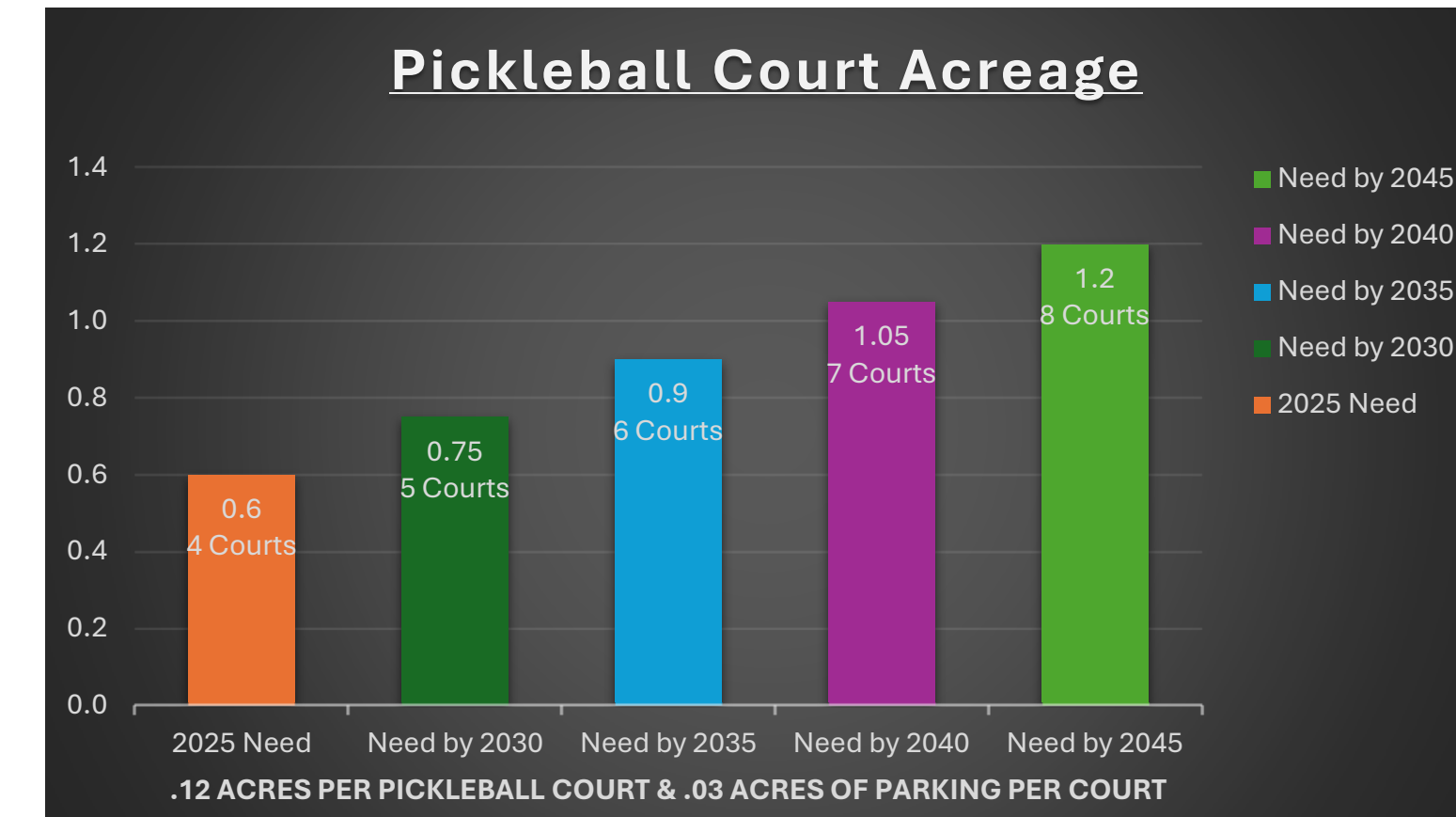
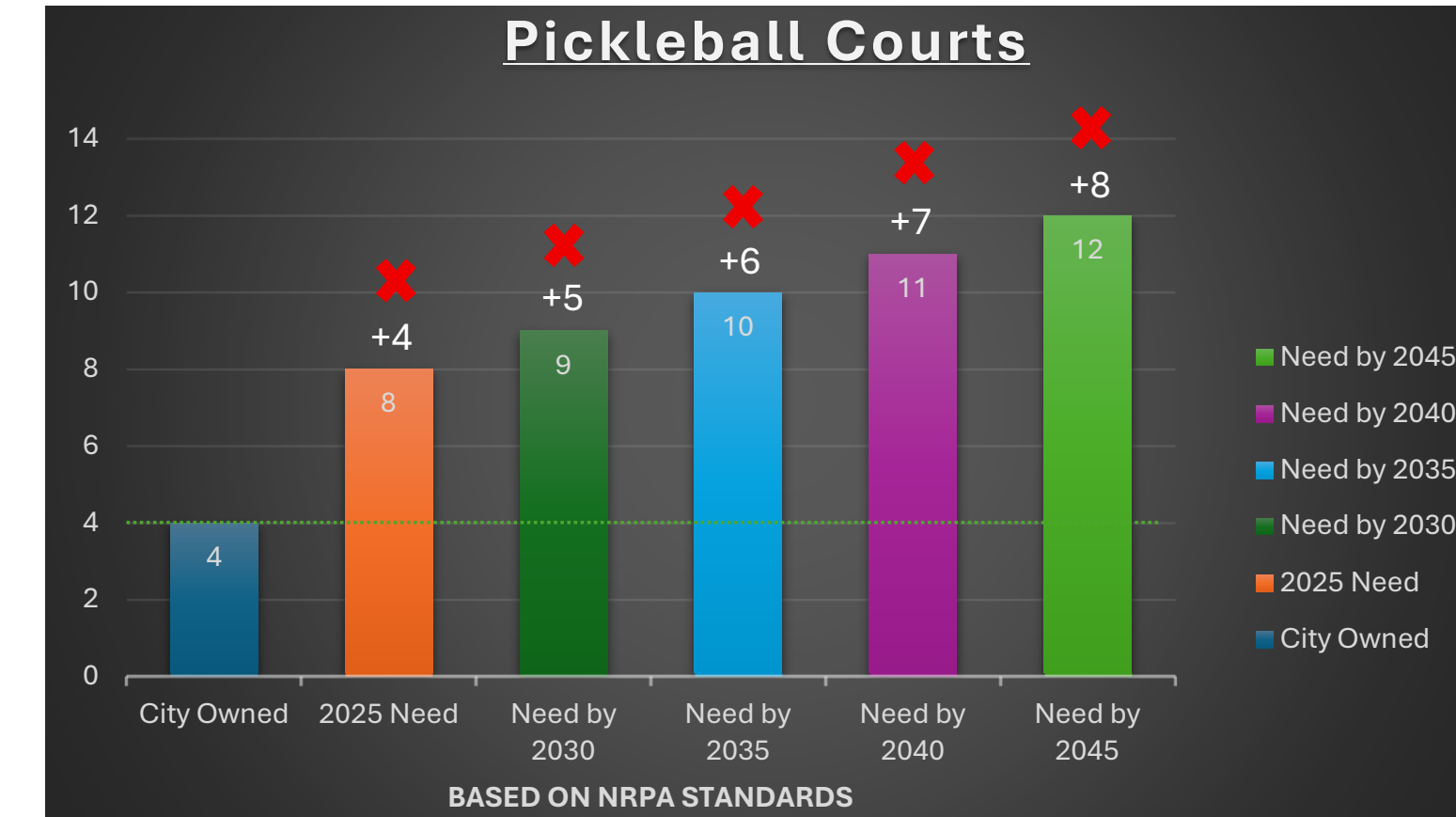
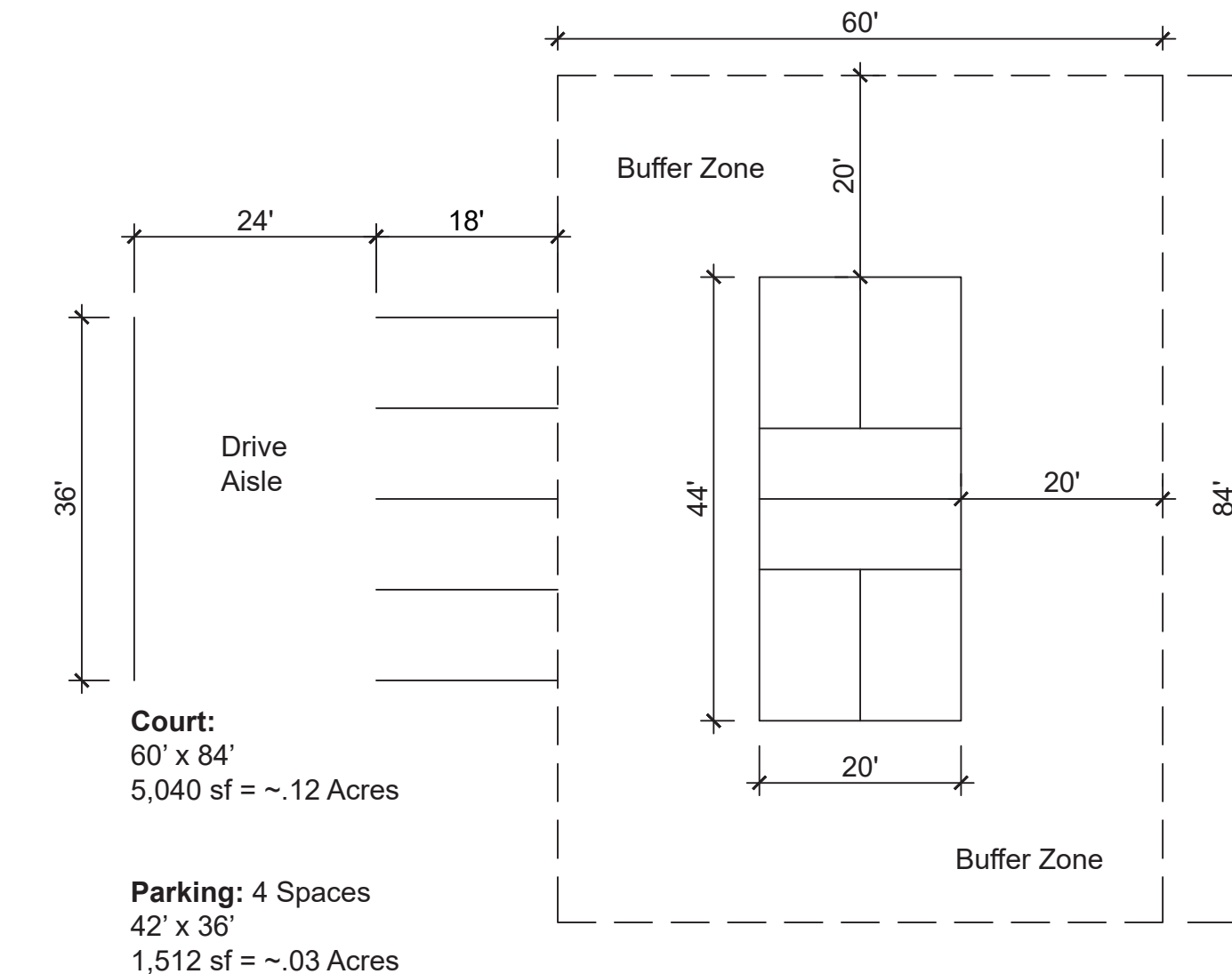

*Reference Appendix B for graphs including non-city owned facilities & Appendix C for Northeast Metropolitan Park Fees

*Reference Appendix B for graphs including non-city owned facilities

Projected Skate Parks

NRPA Standards: 1 skate park per group of 61,384 residents.

2025: The City's current inventory meets NRPA Standards, but skate park demand should be re-evaluated every 5 years as population and participation trends evolve.

Leagues and organizations who use facilities: N/A

Age levels who use facilities: All ages

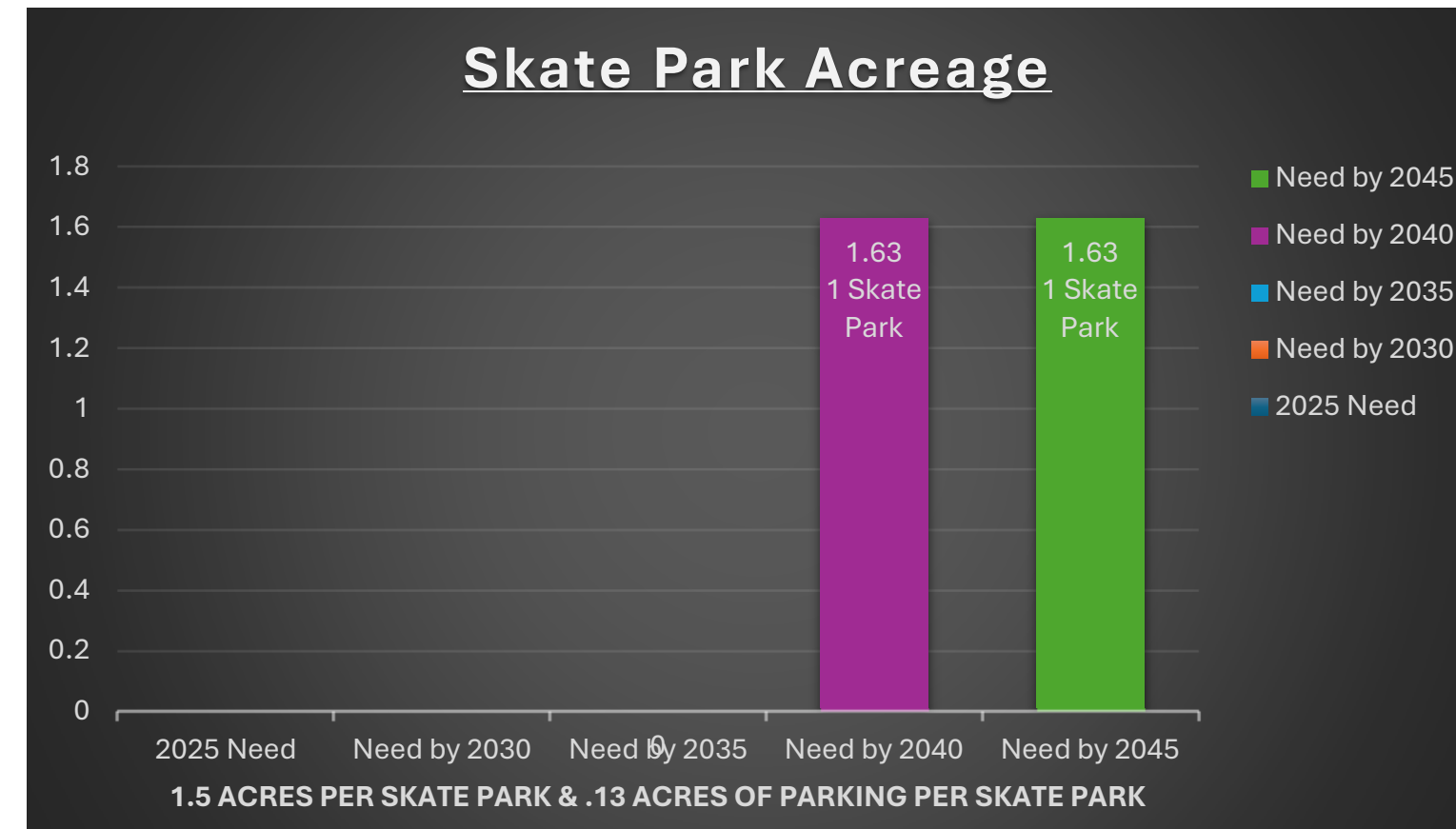
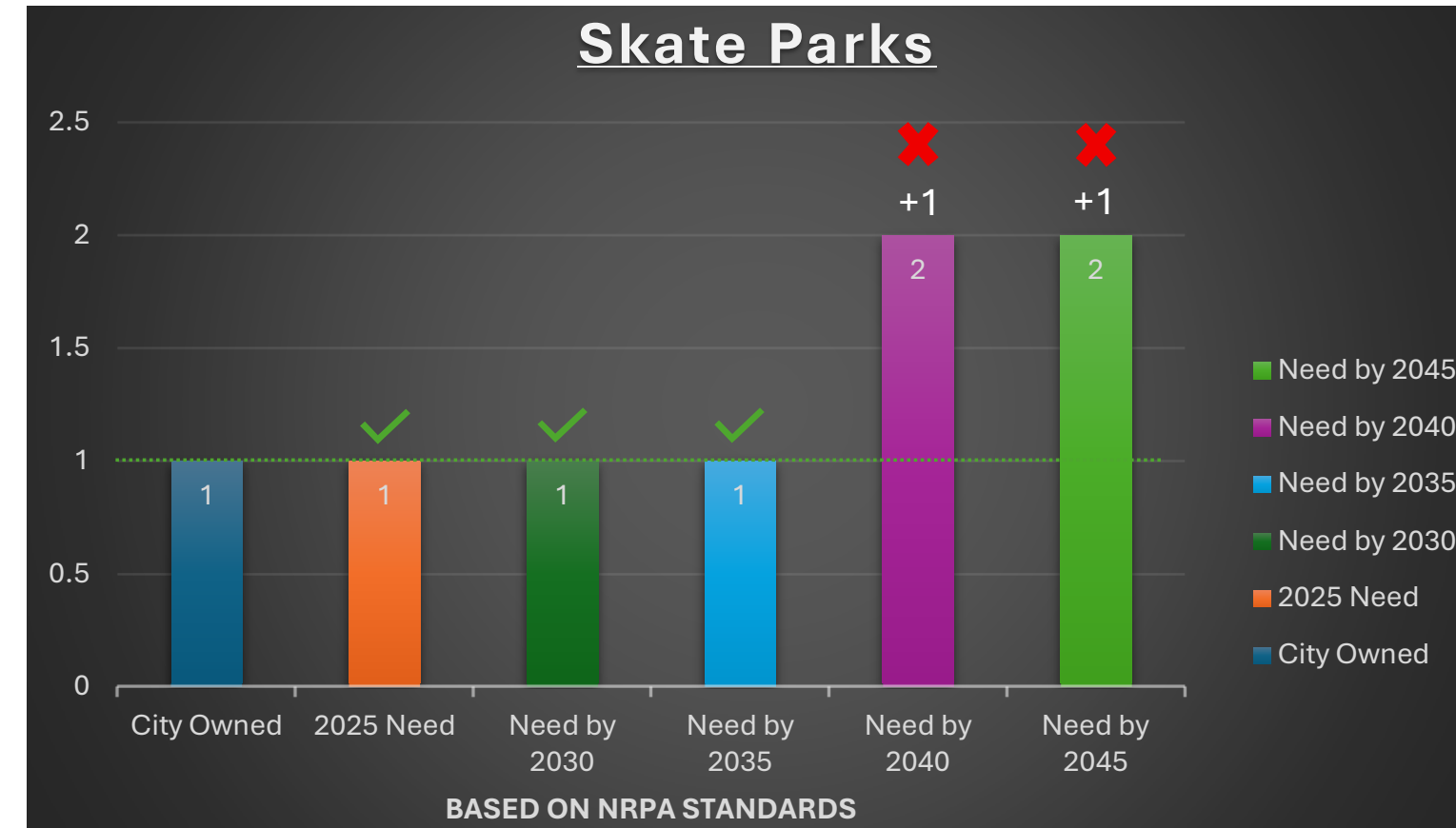

Projected Soccer Fields

NRPA Standards: 1 soccer field per group of 4,659 residents.

The graph to the right uses an 18U, 11v11 as the basis for field size due to existing demand and age demographics of the city.

2025: The City's current field inventory does not meet NRPA Standards for the 2025 population.

Leagues and organizations who use facilities: Pflugerville Area Youth Soccer League (PAYSL), Capital City, One World Soccer, Muslim Youth League of Austin (MYLA), Austin Sports and Social Club (ASSC), Mortega FC

Age levels who use facilities: 3-19 year olds

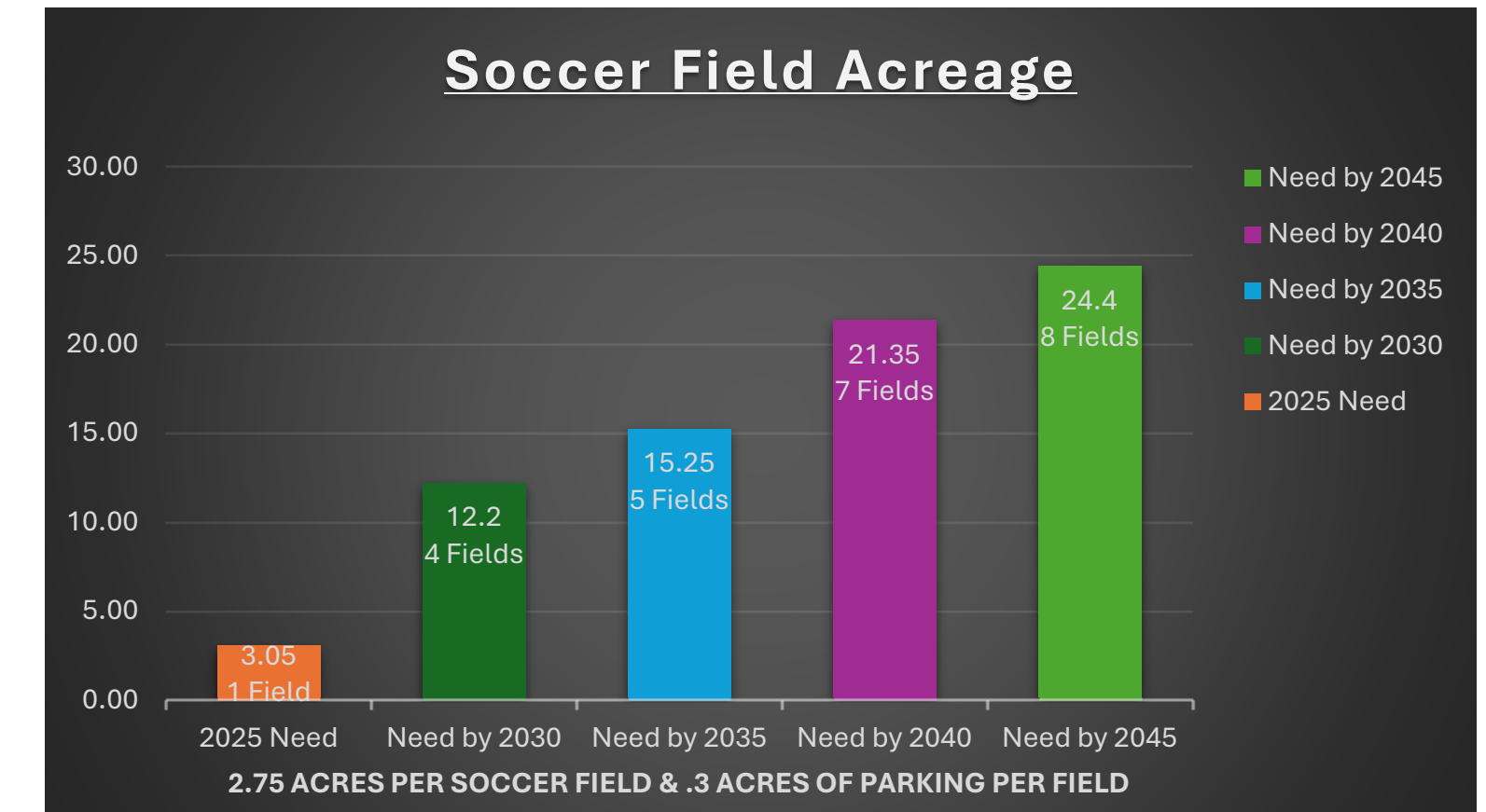
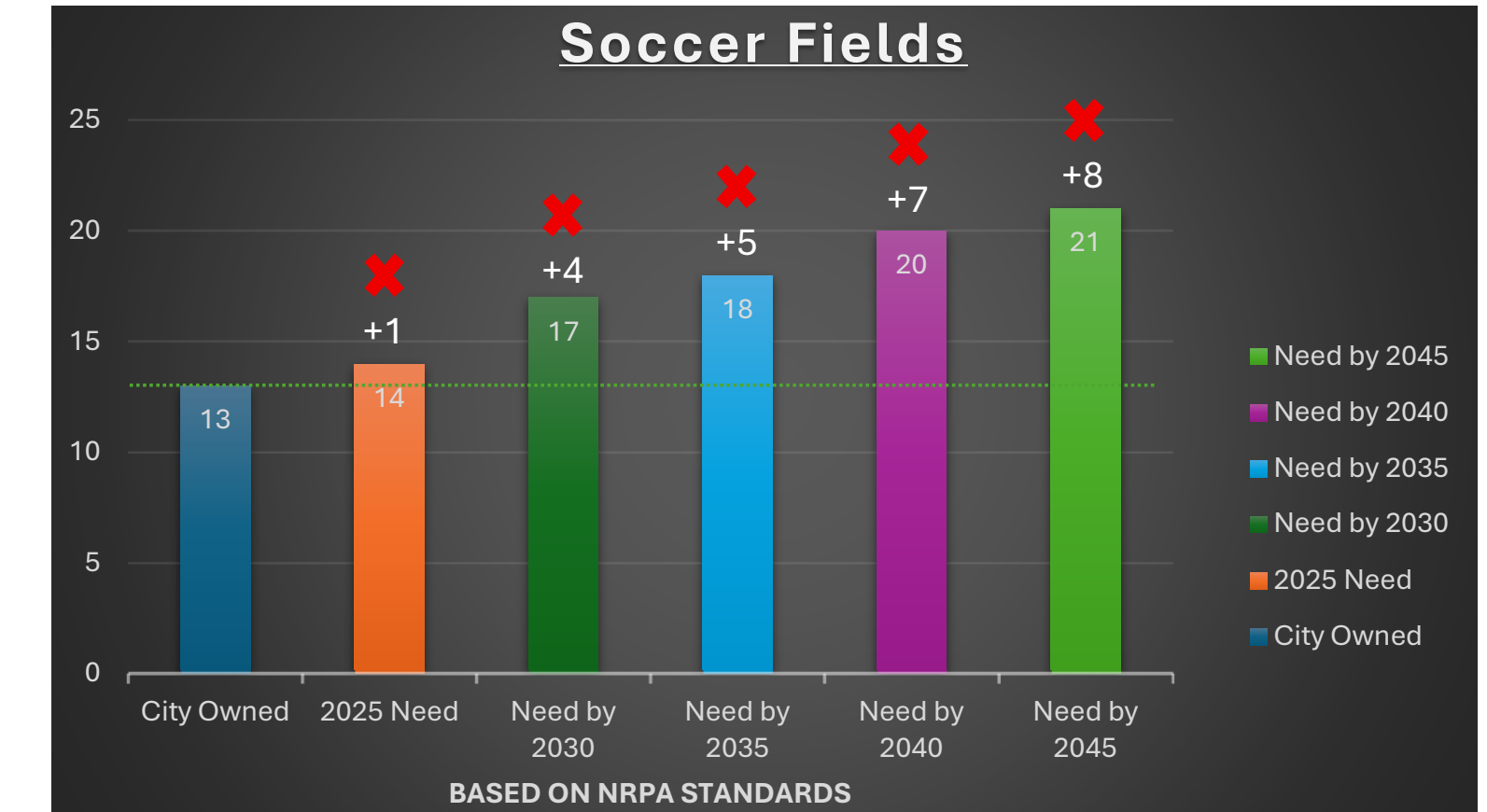
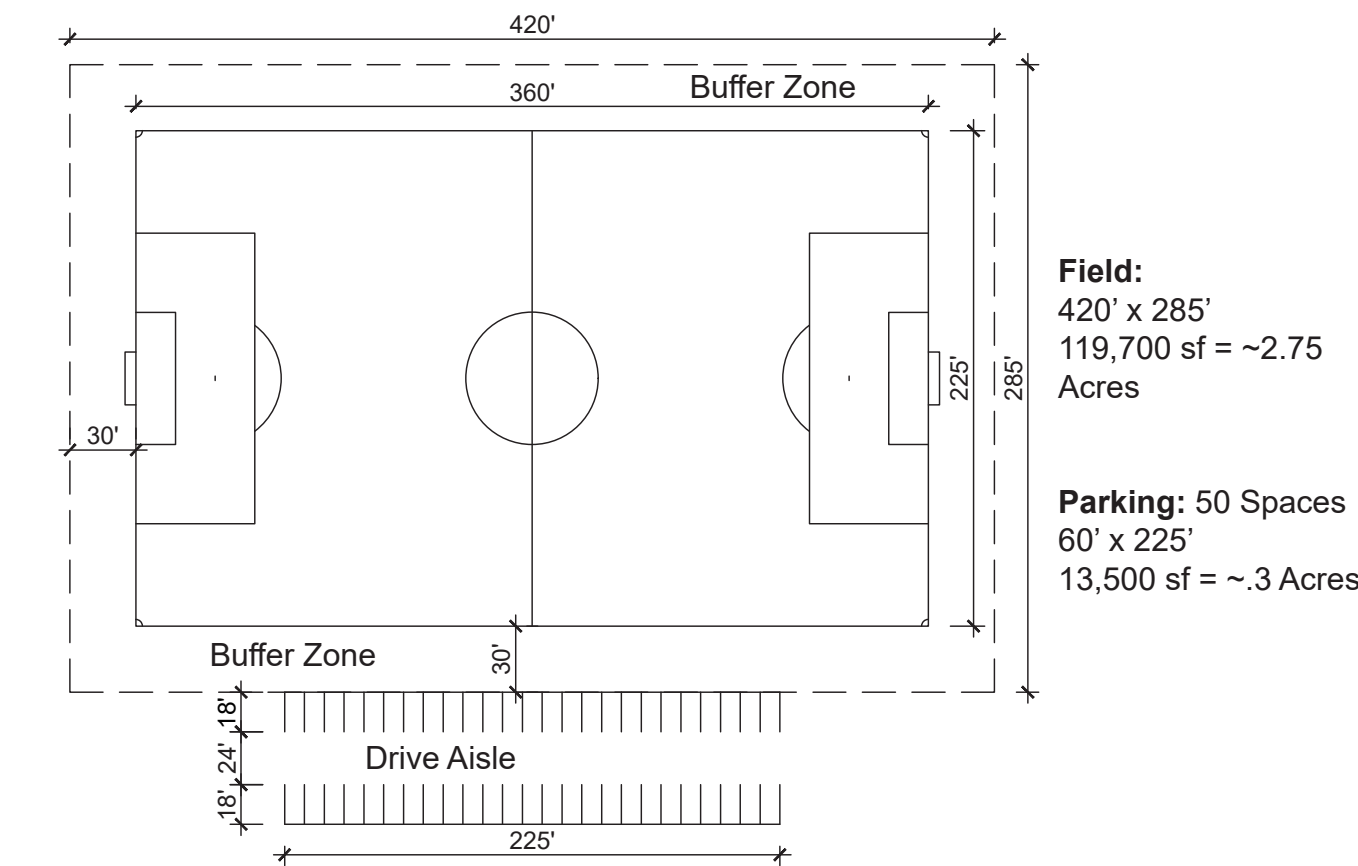

*Reference Appendix B for graphs including non-city owned facilities

*Reference Appendix B for graphs including non-city owned facilities & Appendix C for Northeast Metropolitan Park Fees

Projected Tennis Courts

NRPA Standards: 1 tennis court per group of 5,818 residents.

2025: The City's current court inventory is significantly lower than NRPA Standards for the 2025 population.

Leagues and organizations who use facilities: Austin Tennis League, Capital Area Tennis Association (CATA), Junior Team Tennis (JTT)

Age levels who use facilities: 6-18 year olds

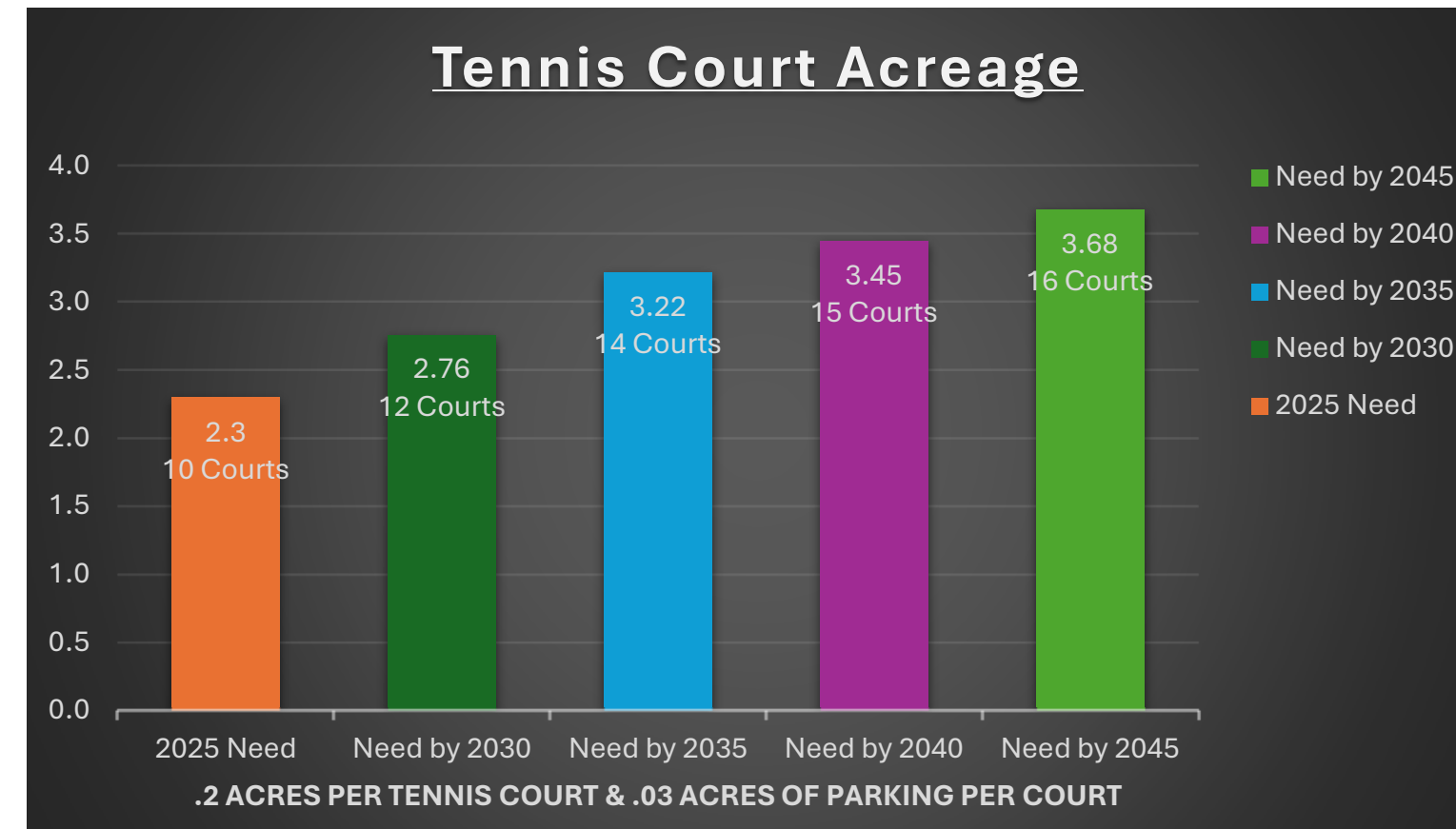
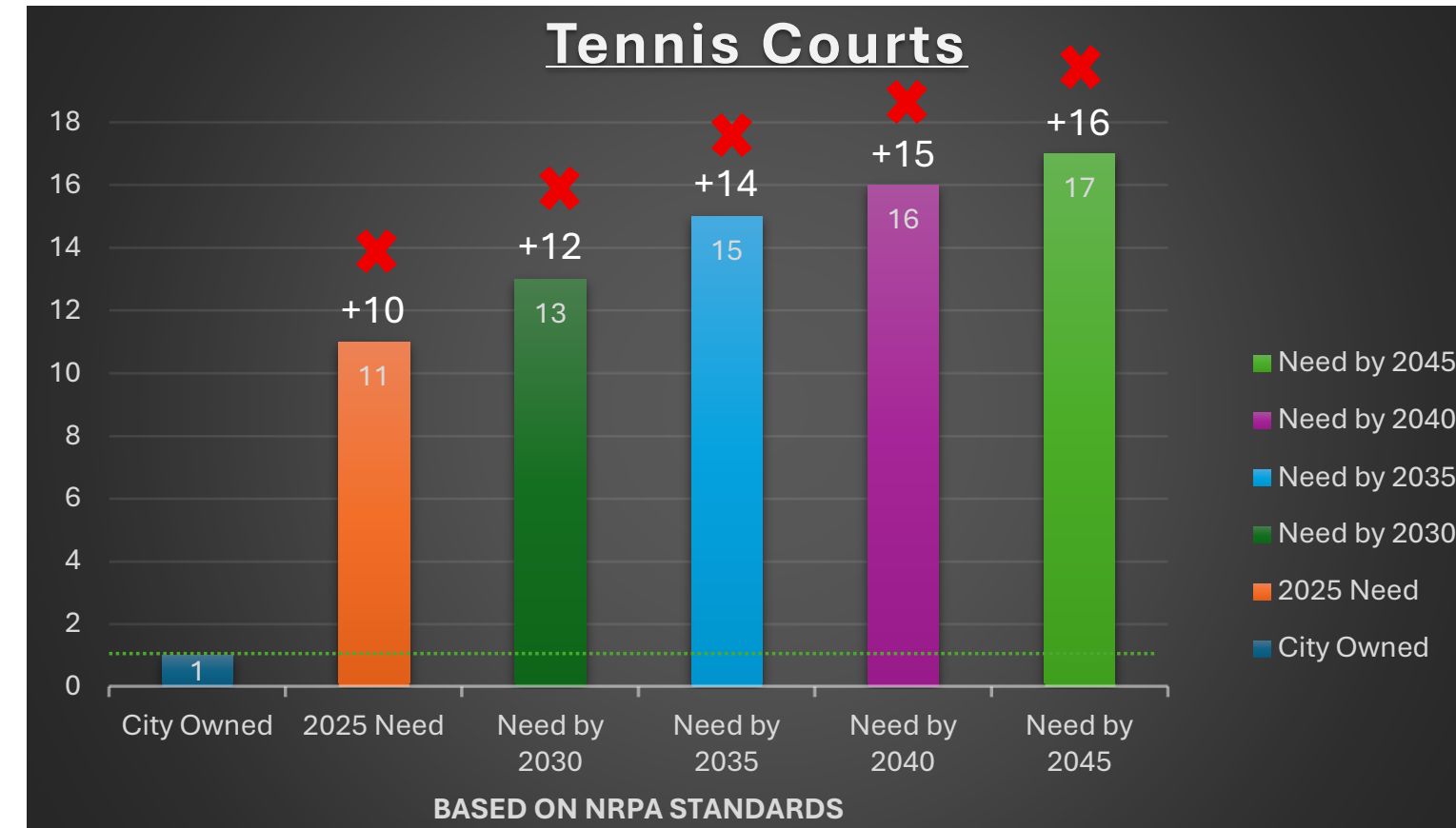
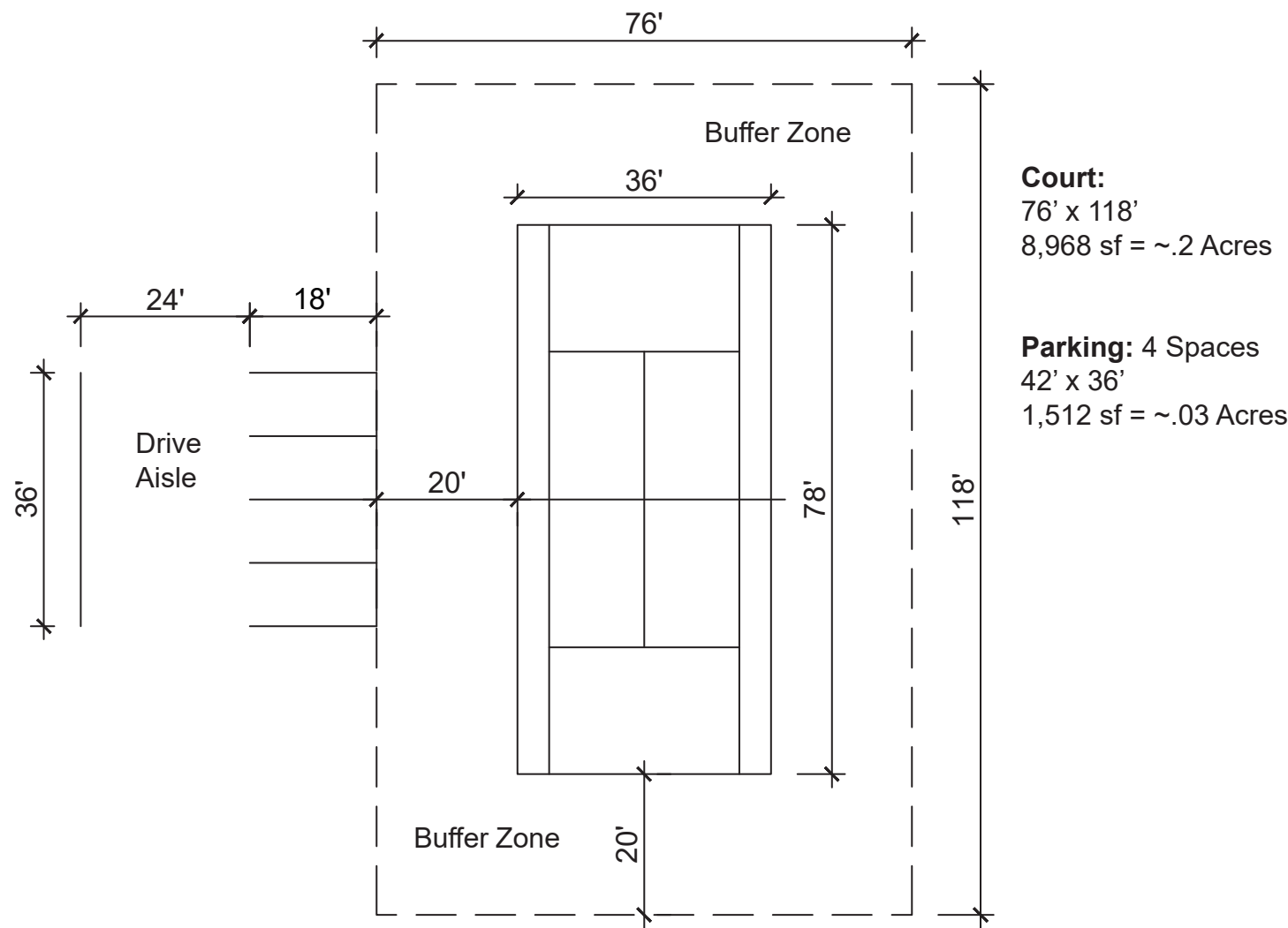

Projected Sand Volleyball Courts

NRPA Standards: 1 sand volleyball court per group of 29,214 residents.

2025: The City's current court inventory meets NRPA Standards, but court demand should be re-evaluated every 5 years as population and participation trends evolve.

Leagues and organizations who use facilities: i9 Sports, Empower Juniors, Austin Sports and Social Club (ASSC)

Age levels who use facilities: 7-14 year olds

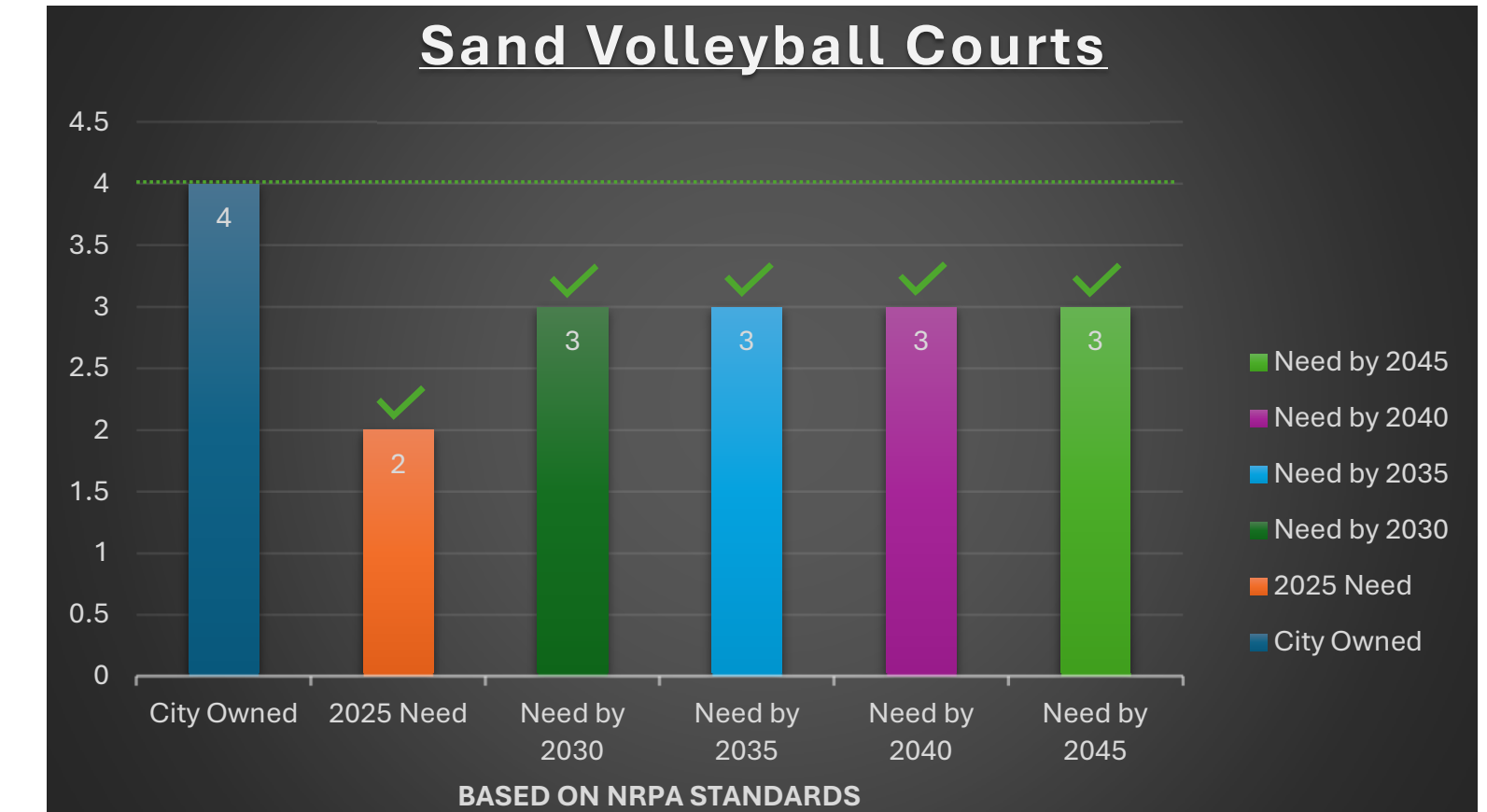
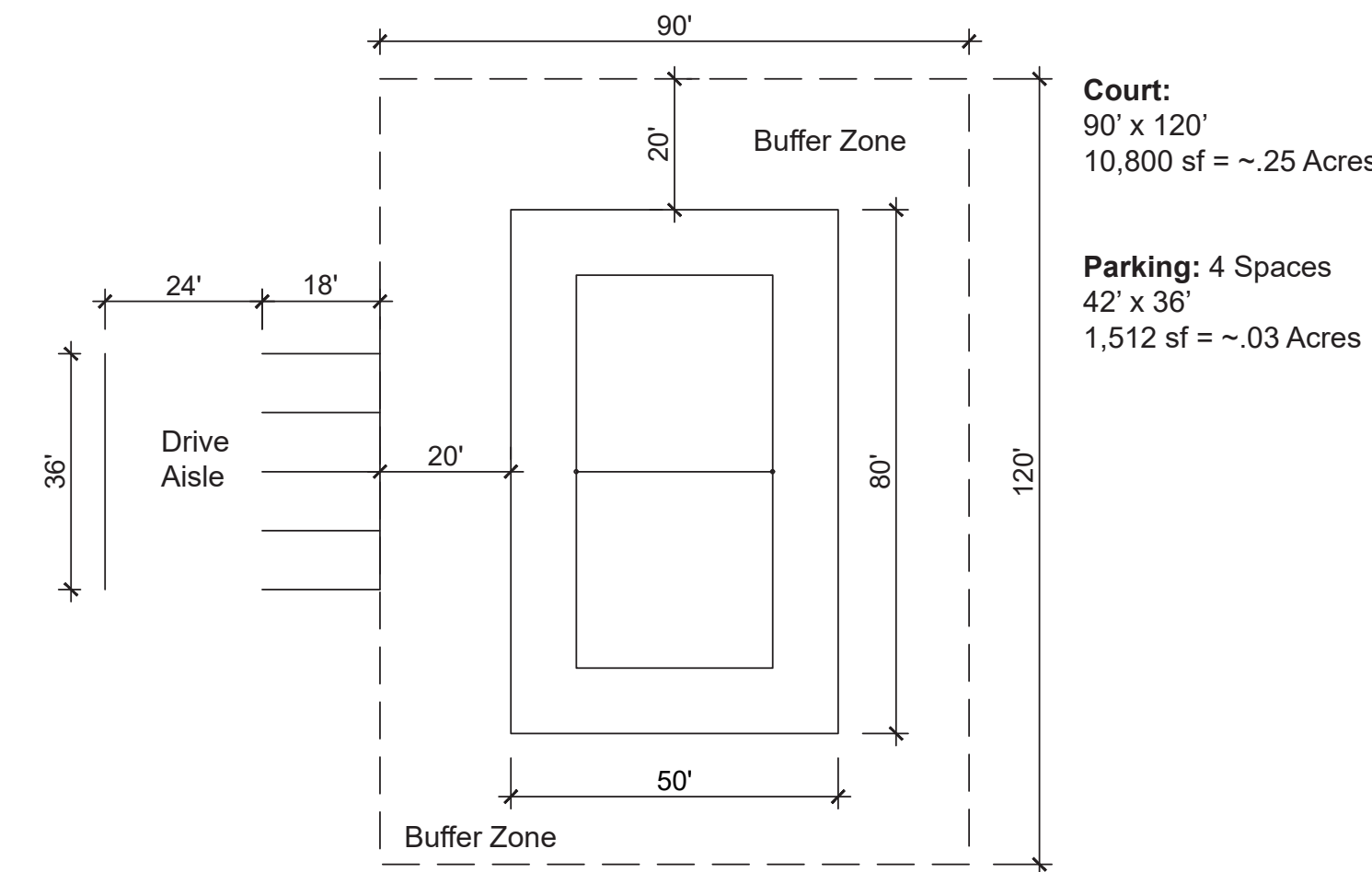

*Reference Appendix B for graphs including non-city owned facilities

*Reference Appendix B for graphs including non-city owned facilities

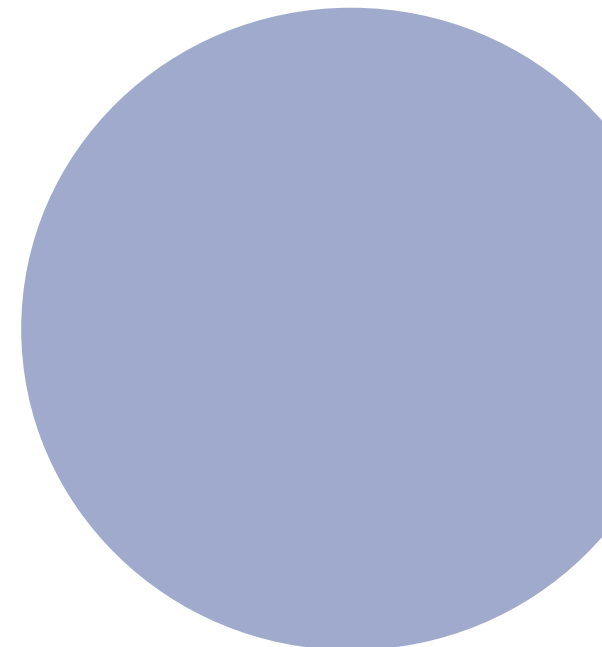

Projected Cricket Grounds

NRPA Standards: There is no NRPA standard.

1 ground per group of 85,220 residents was calculated for this study based on an average per population of Pflugerville, Round Rock, Austin, and Liberty Hill.

2025: The City's current inventory is zero as it has not grown to a population of 85,220. Cricket ground demand should be re-evaluated every 5 years as population and participation trends evolve.

Leagues and organizations who use facilities: Pflugerville Cricket League (PfCL), Austin Tapedball Cricket League (ATCL)

Age levels who use facilities: All ages

2025 Cricket Locations:

- Liberty Hill, Rio Ranch Cricket Fields, Liberty Hill TX 78642, 8 fields (Privately Owned)
 - Pflugerville, 3037 Winding Shore Lane, Pflugerville TX 78660, 1 field
 - Round Rock, 300 Borho Dr, Round Rock, TX 78681 1 field
 - Round Rock, 555 Limmer Loop, Round Rock, TX 78665, 1 field
 - Austin, 6013 Loyola Ln, Austin, TX 78724, 1 field
 - Round Rock, 3079 Whitlow Way Round Rock, TX 78665, 1 field
 - Pflugerville, 5001 Killingsworth Ln Pflugerville, TX 78660, 1 field
- *Reference Appendix C for Northeast Metropolitan Park Fees

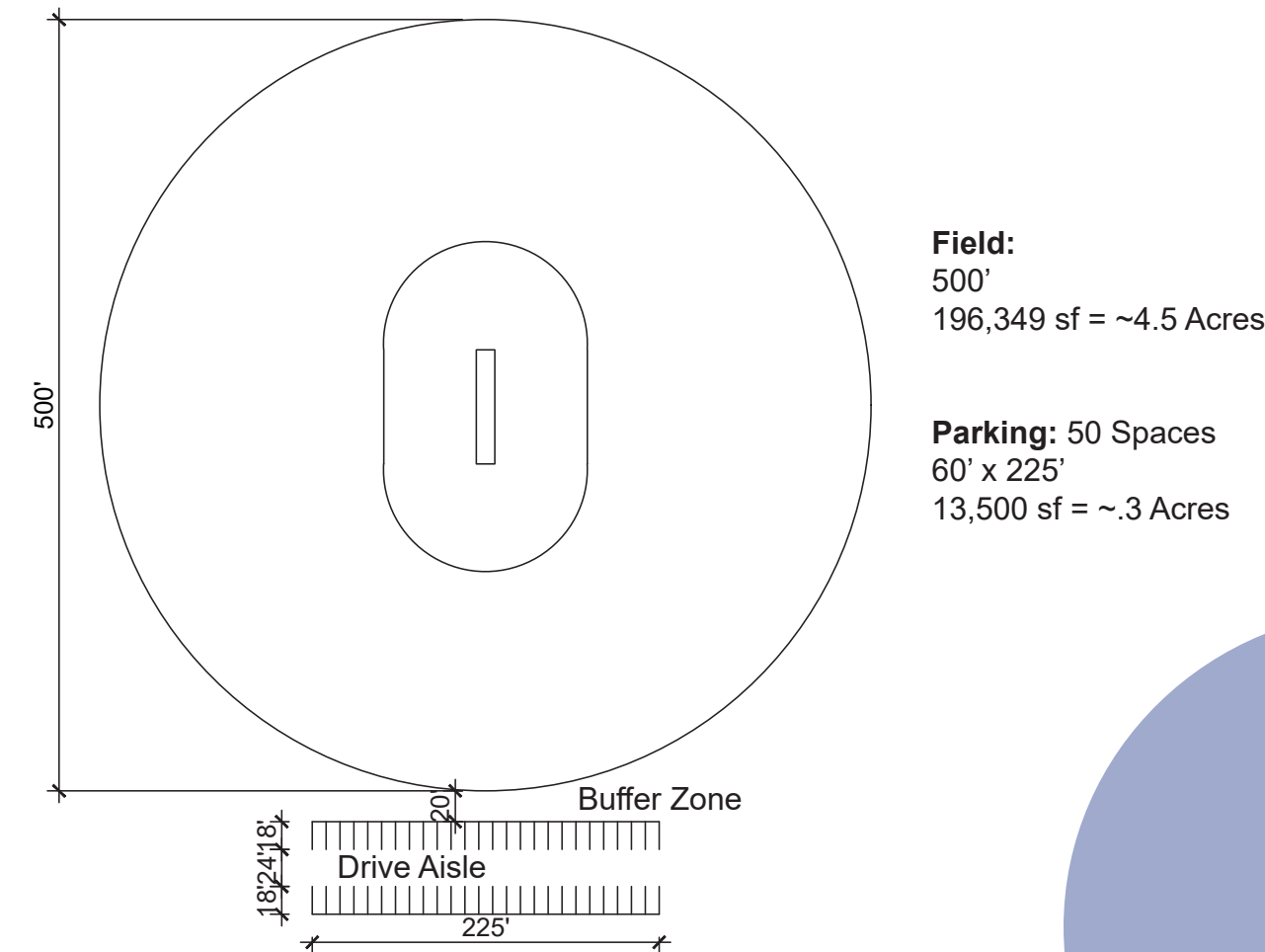
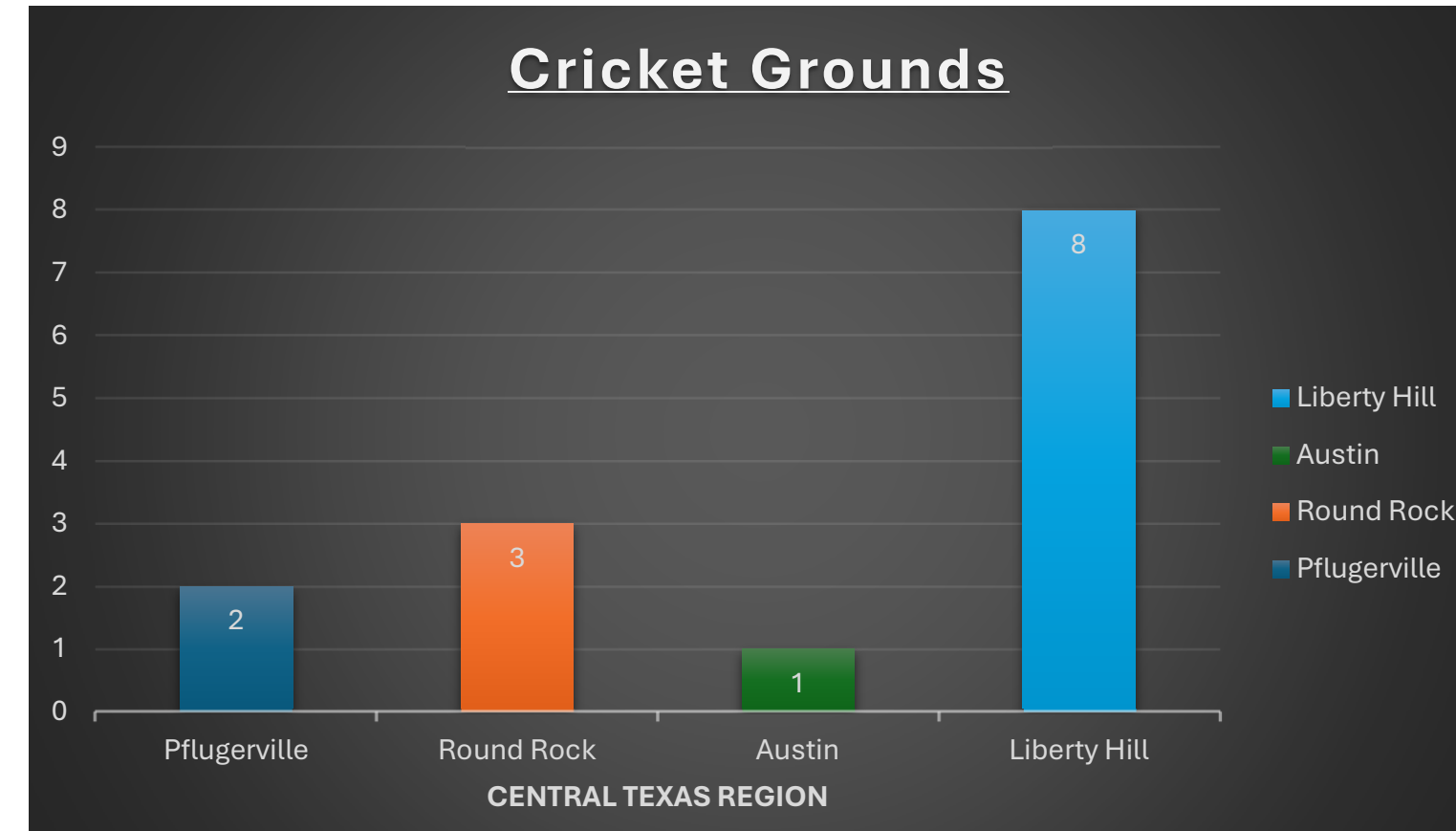

Public Engagement

- The Process:** Stakeholder interviews are an essential component of the feasibility study process, providing critical qualitative data to inform the feasibility report. These interviews involve engaging with key individuals and organizations who have a vested interest in the project's outcome, such as the sports associations mentioned. The purpose of these discussions is to identify needs, priorities, considerations, and potential challenges from multiple perspectives. Insights gathered through stakeholder interviews help ensure that the feasibility analysis is comprehensive, accurately reflects stakeholder expectations, and supports the development of practical and well-informed recommendations.
- Diverse Participation:** These organizations collectively serve a wide demographic, from youth (PAYSL, Pflugerville Force, PAYBAS, Austin Ultimate Youth) to adults (ATCL, Austin Ultimate Adult) and seniors (Austin Ultimate Seniors), with thousands of players involved in soccer, cricket, tackle/flag football, cheer, ultimate frisbee, baseball, and softball.
- Pflugerville Residency:** A significant portion of players are Pflugerville residents, ranging from approximately 50% in ATCL, 70% in PAYSL, 90% in Pflugerville Force, and 80-85% in PAYBAS, demonstrating a strong local engagement.
- Facility Usage & Needs:** Northeast Metropolitan Park is a key shared location, but all organizations express a need for improved and expanded facilities. This includes more dedicated field space (soccer, football, baseball, softball, cricket), better lighting, scoreboards, spectator seating, batting cages, concessions, storage, and restrooms, with specific requests for consolidating fields in one location for practice and games.
- Growth & Demand:** All associations report consistent or increasing growth, with some, like Pflugerville Force, turning away participants due to capacity limitations, highlighting the urgent need for addressing facility and resource constraints.
- Summary:** Pflugerville's public engagement efforts highlight a thriving local sports scene, encompassing a diverse range of organizations like the Austin Tapedball Cricket League, Pflugerville Force, Austin Ultimate, PAYSL, and PAYBAS. All of these associations are experiencing consistent growth and feature significant participation from Pflugerville residents, yet they universally face challenges related to inadequate sports facilities. There's a pressing need for more dedicated field space, enhanced lighting, scoreboards, batting cages and essential amenities such as concessions, and restrooms, particularly as some organizations are already turning away participants. There is an urgent need for collaborative solutions and infrastructure development to support the community's expanding athletic interests.

*Reference Appendix D for detailed meeting notes

Estimated Acreage & Pricing

The tables below illustrate the pricing and acreage required for each facility, along with the associated parking needs. Based on these tables and the estimated quantities derived from NRPA standards, we can project the total cost and acreage necessary to accommodate these needs.

*Pricing is based on 2025 estimates.

Facility Acreage & Pricing

Feature	Acres Needed for 1	Price Per 1	2025 Need	Need in 2030	Need in 2035	Need in 2040	Need in 2045
Basketball Court	0.25	\$150,000.00	-	-	1	2	3
Baseball Field	3	\$2,200,000.00	13	15	17	18	20
Softball Field	2	\$1,425,000.00	14	16	18	19	21
Disc Golf Course - 18	36	\$2,000,000.00	-	-	1	1	1
Football / Rugby / Lacrosse	2.12	\$1,500,000.00	7	10	11	13	14
Pickleball Court	0.12	\$100,000.00	4	5	6	7	8
Skate Park	1.5	\$4,500,000.00	-	-	-	1	1
Soccer Field	2.75	\$1,900,000.00	1	4	5	7	8
Tennis Court	0.2	\$150,000.00	10	12	14	15	16

Parking Acreage & Pricing

Feature	Acres Needed for 1	Price Per 1	2025 Need	Need in 2030	Need in 2035	Need in 2040	Need in 2045
Basketball Parking	0.13	\$54,300.00	-	-	1	2	3
Baseball Parking	0.22	\$87,500.00	13	15	17	18	20
Softball Parking	0.22	\$87,500.00	14	16	18	19	21
Disc Golf Parking	0.275	\$107,890.00	-	-	1	1	1
Football / Rugby / Lacrosse Parking	0.3	\$130,250.00	7	10	11	13	14
Pickleball Parking	0.03	\$18,160.00	4	5	6	7	8
Skate Park Parking	0.13	\$54,300.00	-	-	-	1	1
Soccer Parking	0.3	\$130,250.00	1	4	5	7	8
Tennis Parking	0.03	\$18,160.00	10	12	14	15	16

Overall Acreage & Pricing

Feature	Acres Needed for 1	Price Per 1	2025 Need	Need in 2030	Need in 2035	Need in 2040	Need in 2045
Basketball Court	0.38	\$204,300.00	-	-	1	2	3
Baseball Field	3.22	\$2,287,500.00	13	15	17	18	20
Softball Field	2.22	\$1,512,500.00	14	16	18	19	21
Disc Golf Course - 18	36.275	\$2,107,890.00	-	-	1	1	1
Football / Rugby / Lacrosse	2.42	\$1,630,250.00	7	10	11	13	14
Pickleball Court	0.15	\$118,160.00	4	5	6	7	8
Skate Park	1.63	\$4,554,300.00	-	-	-	1	1
Soccer Field	3.05	\$2,030,250.00	1	4	5	7	8
Tennis Court	0.23	\$168,160.00	10	12	14	15	16

Estimated 2025 Pricing

The following tables outline the projected pricing and acreage required to accommodate facility needs in five-year increments. This information can be used to estimate the total acreage necessary to support future facilities as well as the anticipated costs associated with ongoing development.

*Pricing is based on 2025 estimates.

2025 Need

Feature	Acres Needed for 1	*Price Per 1	2025 Need	Acres Needed	*Price Per Need
★ Baseball Field	3.22	\$2,287,500.00	13	41.86	\$29,737,500.00
★ Softball Field	2.22	\$1,512,500.00	14	31.08	\$21,175,000.00
Tennis Court	0.23	\$168,160.00	10	2.3	\$1,681,600.00
★ Football / Rugby / Lacrosse	2.42	\$1,630,250.00	7	16.94	\$11,411,750.00
Pickleball Court	0.15	\$118,160.00	4	0.6	\$472,640.00
★ Soccer Field	3.05	\$2,030,250.00	1	3.05	\$2,030,250.00
			<i>Contingency (20%)</i>		\$13,301,748.00
			Total	95.83	\$79,810,488.00

★ 12U Full synthetic turf field. *With fencing, spectator seating and shade, dugouts, scoreboards, lighting, warm-up area, etc.

★ 12U Full synthetic turf field. *With fencing, spectator seating and shade, dugouts, scoreboards, lighting, warm-up area, etc.

★ Synthetic turf field. *With lighting.

★ 36 Acres including 1' of grading over the entire site, irrigation, seeding, 15 trees per acre, tee boxes, and baskets.

* Land acquisition price not included

*** Itemized Costs Do Not Include Land Acquisition Costs**

Estimated 2030 Pricing

*Pricing is based on 2025 estimates with added inflation.

Need by 2030

Feature	Acres Needed for 1	*Price Per 1	Need by 2030	Acres Needed	*Price Per Need
★ Baseball Field	3.22	\$2,287,500.00	15	48.3	\$34,312,500.00
★ Softball Field	2.22	\$1,512,500.00	16	35.52	\$24,200,000.00
Tennis Court	0.23	\$168,160.00	12	2.76	\$2,017,920.00
★ Football / Rugby / Lacrosse	2.42	\$1,630,250.00	10	24.2	\$16,302,500.00
Pickleball Court	0.15	\$118,160.00	5	0.75	\$590,800.00
★ Soccer Field	3.05	\$2,030,250.00	4	12.2	\$8,121,000.00
			<i>Contingency (20%)</i>		\$17,108,944.00
			<i>Inflation (13.14%)</i>		\$11,240,576.21
			Total	123.73	\$113,894,240.21

★ 12U Full synthetic turf field. *With fencing, spectator seating and shade, dugouts, scoreboards, lighting, warm-up area, etc.

★ 12U Full synthetic turf field. *With fencing, spectator seating and shade, dugouts, scoreboards, lighting, warm-up area, etc.

★ Synthetic turf field. *With lighting.

★ 36 Acres including 1' of grading over the entire site, irrigation, seeding, 15 trees per acre, tee boxes, and baskets.

* Land acquisition price not included

*** Itemized Costs Do Not Include Land Acquisition Costs**

Estimated 2035 Pricing

*Pricing is based on 2025 estimates with added inflation.

Need by 2035

Feature	Acres Needed for 1	*Price Per 1	Need by 2035	Acres Needed	*Price Per Need
★ Baseball Field	3.22	\$2,287,500.00	17	54.74	\$38,887,500.00
★ Softball Field	2.22	\$1,512,500.00	18	39.96	\$27,225,000.00
Tennis Court	0.23	\$168,160.00	14	3.22	\$2,354,240.00
★ Football / Rugby / Lacrosse	2.42	\$1,630,250.00	11	26.62	\$17,932,750.00
Pickleball Court	0.15	\$118,160.00	6	0.9	\$708,960.00
Basketball Court	0.38	\$204,300.00	1	0.38	\$204,300.00
★ Soccer Field	3.05	\$2,030,250.00	5	15.25	\$10,151,250.00
★ Disc Golf Course - 18	36.275	\$2,107,890.00	1	36.28	\$2,107,890.00
			<i>Contingency (20%)</i>		\$19,914,378.00
			<i>Inflation (28.01%)</i>		\$27,890,086.39
			Total	177.35	\$147,376,354.39

★ 12U Full synthetic turf field. *With fencing, spectator seating and shade, dugouts, scoreboards, lighting, warm-up area, etc.

★ 12U Full synthetic turf field. *With fencing, spectator seating and shade, dugouts, scoreboards, lighting, warm-up area, etc.

★ Synthetic turf field. *With lighting.

★ 36 Acres including 1' of grading over the entire site, irrigation, seeding, 15 trees per acre, tee boxes, and baskets.

* Land acquisition price not included

*** Itemized Costs Do Not Include Land Acquisition Costs**

Estimated 2040 Pricing

*Pricing is based on 2025 estimates with added inflation.

Need by 2040

Feature	Acres Needed for 1	*Price Per 1	Need by 2040	Acres Needed	*Price Per Need
★ Baseball Field	3.22	\$2,287,500.00	18	57.96	\$41,175,000.00
★ Softball Field	2.22	\$1,512,500.00	19	42.18	\$28,737,500.00
Tennis Court	0.23	\$168,160.00	15	3.45	\$2,522,400.00
★ Football / Rugby / Lacrosse	2.42	\$1,630,250.00	13	31.46	\$21,193,250.00
Pickleball Court	0.15	\$118,160.00	7	1.05	\$827,120.00
Basketball Court	0.38	\$204,300.00	2	.76	\$408,600.00
★ Soccer Field	3.05	\$2,030,250.00	7	21.35	\$14,211,750.00
★ Disc Golf Course - 18	36.275	\$2,107,890.00	1	36.28	\$2,107,890.00
Skate Park	1.63	\$4,554,300.00	1	1.63	\$4,554,300.00
			<i>Contingency (20%)</i>		<i>\$23,147,562.00</i>
			<i>Inflation (44.83%)</i>		<i>\$51,885,260.22</i>
			Total	196.12	\$190,770,632.22

★ 12U Full synthetic turf field. *With fencing, spectator seating and shade, dugouts, scoreboards, lighting, warm-up area, etc.

★ 12U Full synthetic turf field. *With fencing, spectator seating and shade, dugouts, scoreboards, lighting, warm-up area, etc.

★ Synthetic turf field. *With lighting.

★ 36 Acres including 1' of grading over the entire site, irrigation, seeding, 15 trees per acre, tee boxes, and baskets.

* Land acquisition price not included

*** Itemized Costs Do Not Include Land Acquisition Costs**

Estimated 2045 Pricing

*Pricing is based on 2025 estimates with added inflation.

Need by 2045

Feature	Acres Needed for 1	*Price Per 1	Need by 2045	Acres Needed	*Price Per Need
★ Baseball Field	3.22	\$2,287,500.00	20	64.4	\$45,750,000.00
★ Softball Field	2.22	\$1,512,500.00	21	46.62	\$31,762,500.00
Tennis Court	0.23	\$168,160.00	16	3.68	\$2,690,560.00
★ Football / Rugby / Lacrosse	2.42	\$1,630,250.00	14	33.88	\$22,823,500.00
Pickleball Court	0.15	\$118,160.00	8	1.2	\$945,280.00
Basketball Court	0.38	\$204,300.00	3	1.14	\$612,900.00
★ Soccer Field	3.05	\$2,030,250.00	8	24.4	\$16,242,000.00
★ Disc Golf Course - 18	36.275	\$2,107,890.00	1	36.28	\$2,107,890.00
Skate Park	1.63	\$4,554,300.00	1	1.63	\$4,554,300.00
			<i>Contingency (20%)</i>		<i>\$25,497,786.00</i>
			<i>Inflation (63.86%)</i>		<i>\$81,414,430.70</i>
			Total	213.23	\$234,401,146.70

★ 12U Full synthetic turf field. *With fencing, spectator seating and shade, dugouts, scoreboards, lighting, warm-up area, etc.

★ 12U Full synthetic turf field. *With fencing, spectator seating and shade, dugouts, scoreboards, lighting, warm-up area, etc.

★ Synthetic turf field. *With lighting.

★ 36 Acres including 1' of grading over the entire site, irrigation, seeding, 15 trees per acre, tee boxes, and baskets.

* Land acquisition price not included

*** Itemized Costs Do Not Include Land Acquisition Costs**

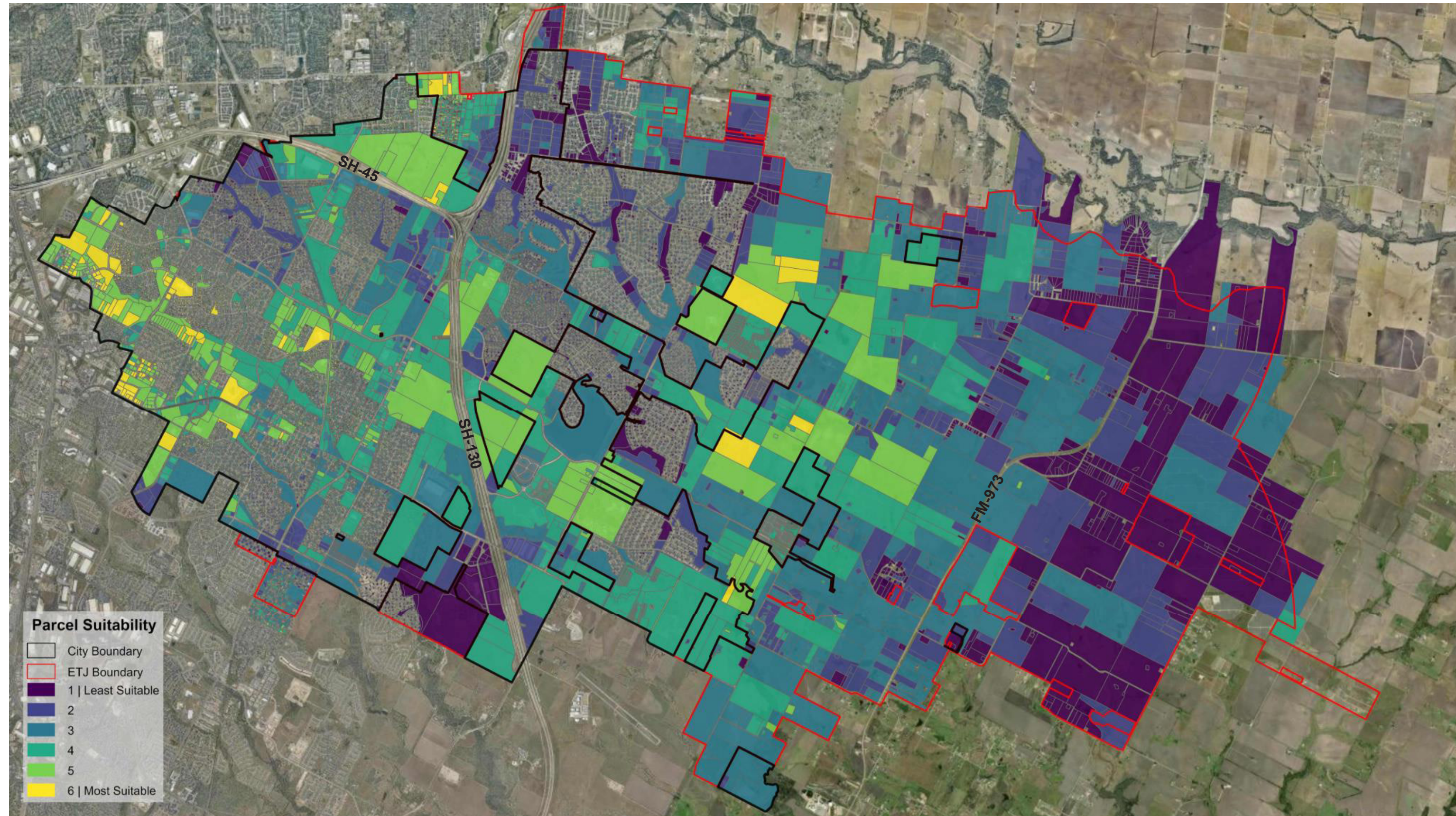

Parcel Suitability

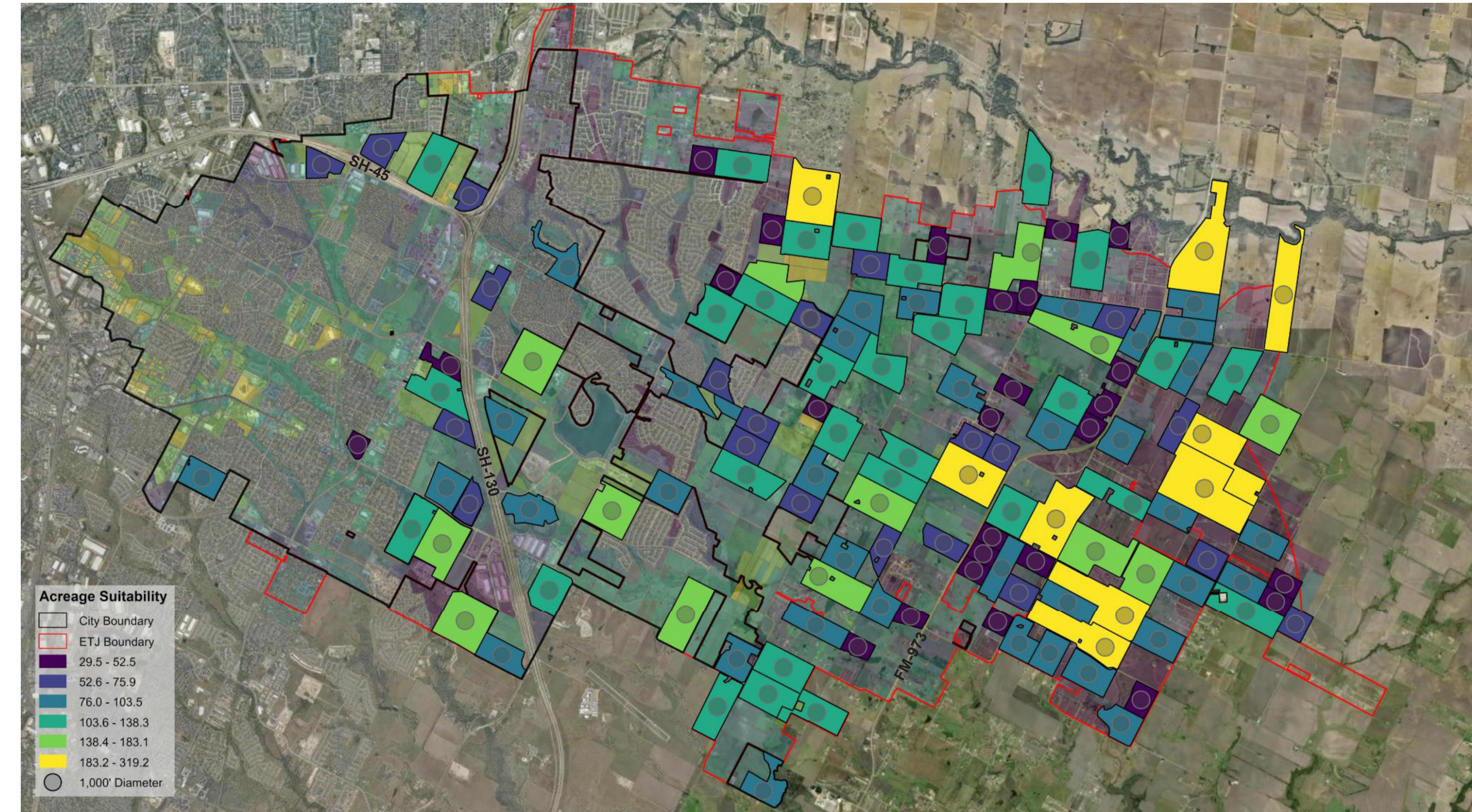

Acreage Suitability

1,000' Diameter - This graphic illustrates the approximate footprint required for a five-field baseball complex.

Appendix

Appendix A - Pflugerville Recreation Allocation Hours

- City of Pflugerville Unmet Field Use Requests & Field Allocation Capacity

Pflugerville Recreation Unmet Field Use Requests 2025				
Name/Org	Date Submitted	Date Requested	Field Type	Total Hours Requested
Austin Ultimate	6/1/2025	6/1/2025	Multipurpose	12
First Down Athletics LLC	8/14/2025	4/25/2026	Football	10
US Sports Camp	6/1/2025	6/9/2025	Soccer	175
Firmament Sports LLC	6/1/2025	6/16/2025	Soccer	100
JUST PLAY SOCCER ORG	6/1/2025	6/18/2025	Soccer	4
Ethio- Austin Kids & Youth Soccer academy	6/1/2025	6/14/2025	Soccer	32
RAGON LOGISTICS LLC	6/18/2025	6/23/2025	Soccer	75
Team Turkey	6/19/2025	6/22/2025	Soccer	2
Angel Chan	6/21/2025	6/22/2025	Soccer	2
Individual Trainings	6/25/2025	6/25/2025	Soccer	32
PFC (offseason)	7/6/2025	7/8/2025	Soccer	32
rccg restoration assembly church	7/13/2025	8/10/2025	Soccer	4
Maria Lombardo	7/18/2025	7/27/2025	Soccer	7
PAYSL	8/1/2025	8/11/2025	Soccer	330
Ovejas de Cristo	8/22/2025	8/24/2025	Soccer	2
SGA (Sonny Guadarrama Academy)	8/25/2025	11/9/2025	Soccer	10
PAYSL U12 Girls	9/16/2025	9/16/2025	Soccer	21
Visa	10/17/2025	10/20/2025	Soccer	10
Total Unmet Demand				860

Pflugerville Recreation Field Allocation Capacity			
Program Season	Allocated Hours	Waitlist Hour Requests	% Waitlist
Fall 2023	2663.75	Unknown	
Spring 2024	2525.25	Unknown	
Fall 2024	6682.5	Unknown	
Spring 2025	6682.5	Unknown	
Fall 2025	7462.5	860	11.52%

Appendix A - NRPA Metrics Study

- City of Pflugerville Owned Facilities & Non-City Owned Facilities within City Limits & ETJ.

NRPA Park Metrics

Feature	2025 City Owned A	2025 Non-City Owned B	NRPA Standard (1 PER Group of Residents) C	2025 Total Need (Pop. 66,819) C	2025 Deficit = C - (A+B)	2030 Total Projected Need (Est. Pop. 77,224) D	2030 Deficit = D - (A+B)	2035 Total Projected Need (Est. Pop. 84,652) E	2035 Deficit = E - (A+B)	2040 Total Projected Need (Est. Pop. 92,079) F	2040 Deficit = F - (A+B)	2045 Total Projected Need (Est. Pop. 99,507) G	2045 Deficit = G - (A+B)
Basketball Court	9	1	8,447	8	-2	9	-1	10	0	11	1	12	2
Baseball Field	2	13	4,560	15	0	17	2	19	4	20	5	22	7
Softball Field	1	2	4,560	15	12	17	14	19	16	20	17	22	19
Disc Golf Course	1	1	56,150	1	-1	1	-1	2	0	2	0	2	0
Football / Rugby / Lacrosse	7	4	4,659	14	3	17	6	18	7	20	9	21	10
Pickleball Court	4	5	8,592	8	-1	9	0	10	1	11	2	12	3
Skate Park	1	1	61,384	1	-1	1	-1	1	-1	2	0	2	0
Soccer Field	13	18	4,659	14	-17	17	-14	18	-13	20	-11	21	-10
Tennis Court	1	10	5,818	11	0	13	2	15	4	16	5	17	6
Sand Volleyball Court	4	1	29,214	2	-3	3	-2	3	-2	3	-2	3	-2
Cricket Ground	0	2	No Official Standard										

Outdoor

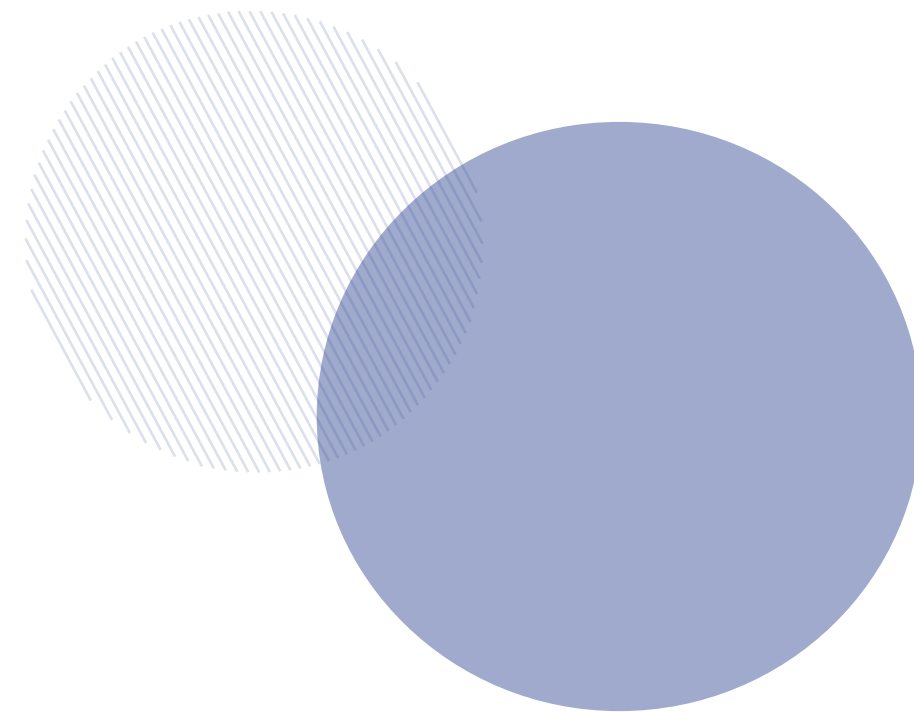
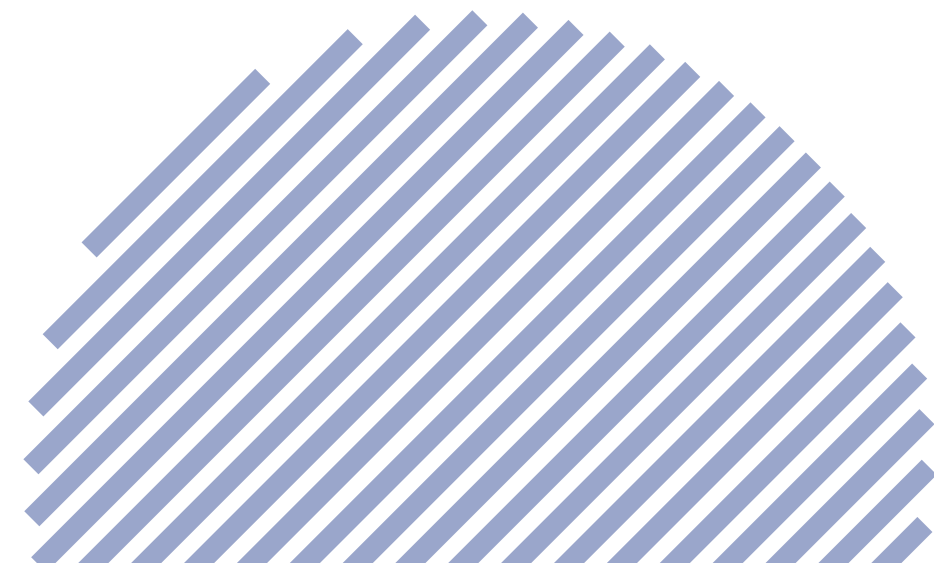

Appendix B - Projected Basketball Courts

*Includes city and non-city owned facilities

NRPA Standards: 1 basketball court per group of 8,447 residents.

2025: Needs are currently met when considering city and non-city owned facilities.

Leagues and organizations who use facilities: Pflugerville Youth Basketball Association (PYBA)

Age levels who use facilities: 6-14 year olds

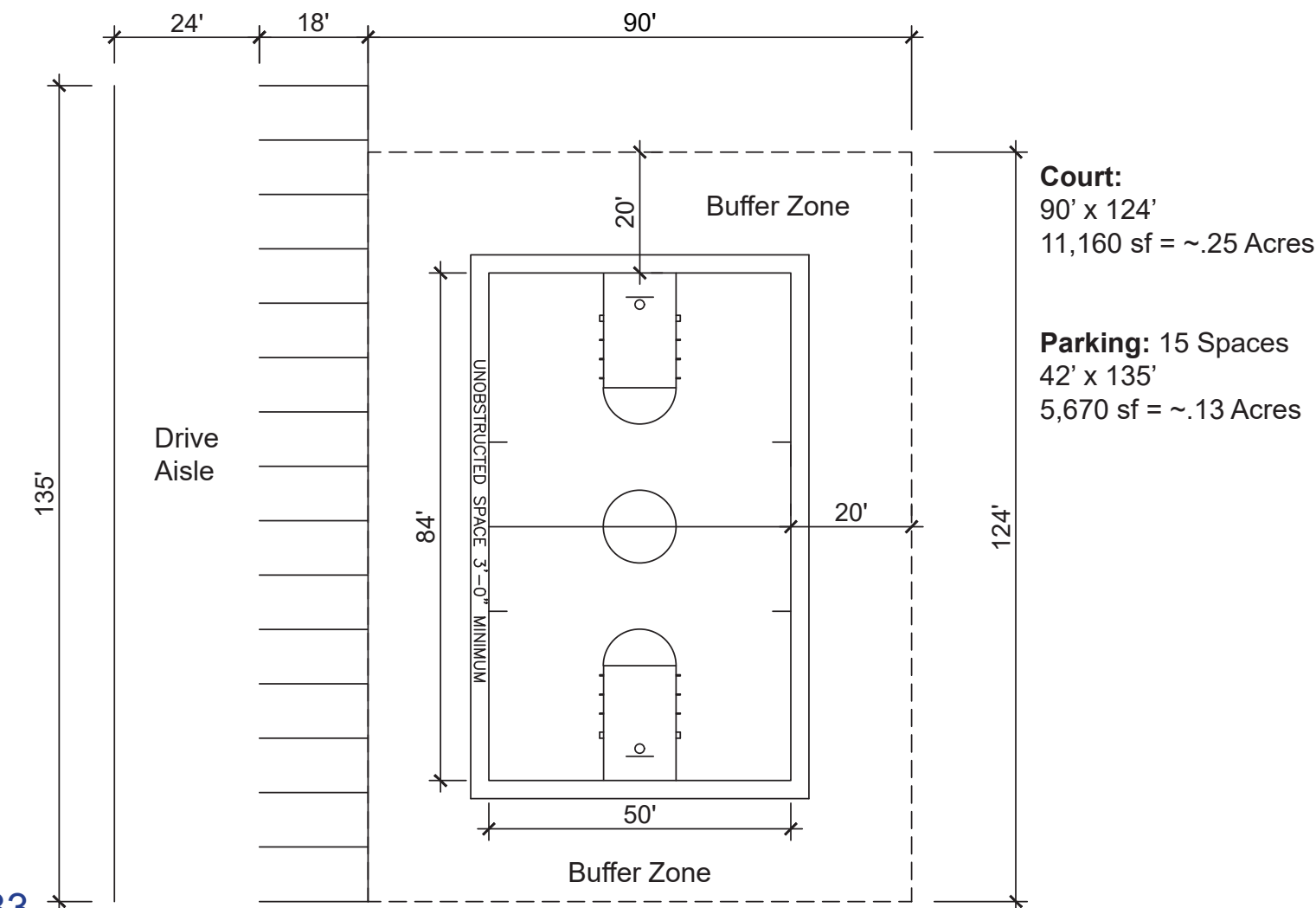

Basketball Courts

Appendix B: Includes City & Non-City Owned Facilities

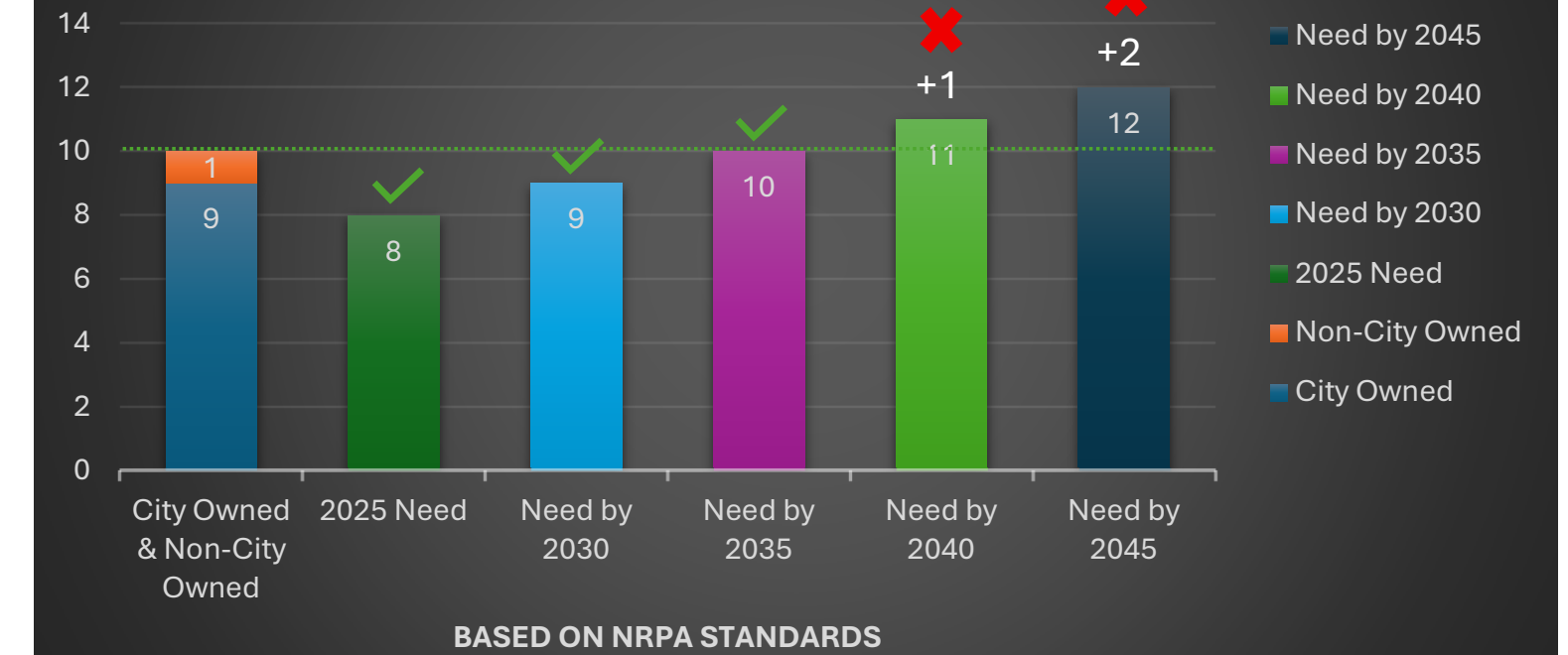

BASED ON NRPA STANDARDS

Basketball Court Acreage

Appendix B: Includes City & Non-City Owned Facilities

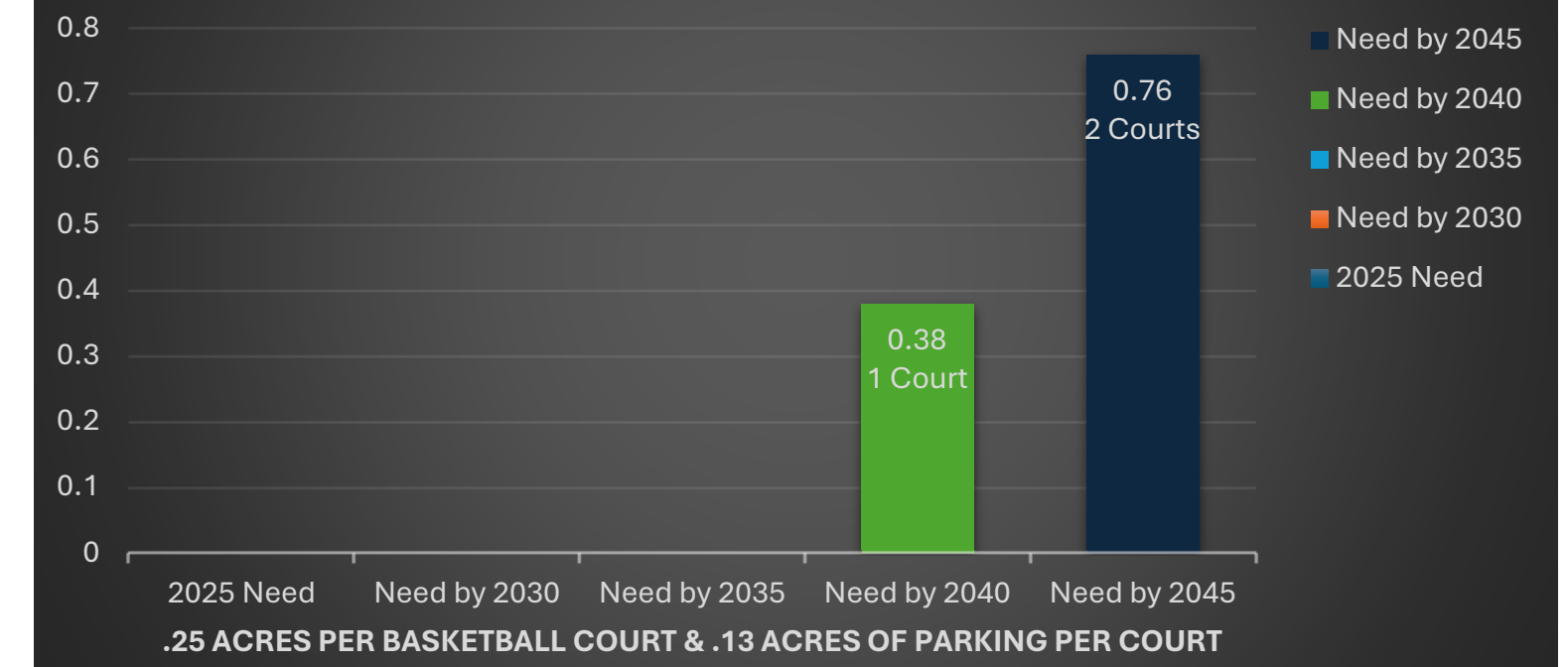

Appendix B - Projected Baseball Fields

*Includes city and non-city owned facilities

NRPA Standards: 1 baseball field per group of 4,560 residents.

2025: Needs are currently met when considering city and non-city owned facilities.

Leagues and organizations who use facilities: Pflugerville Area Youth Baseball And Softball (PAYBAS)
Age levels who use facilities: 4-14 year olds

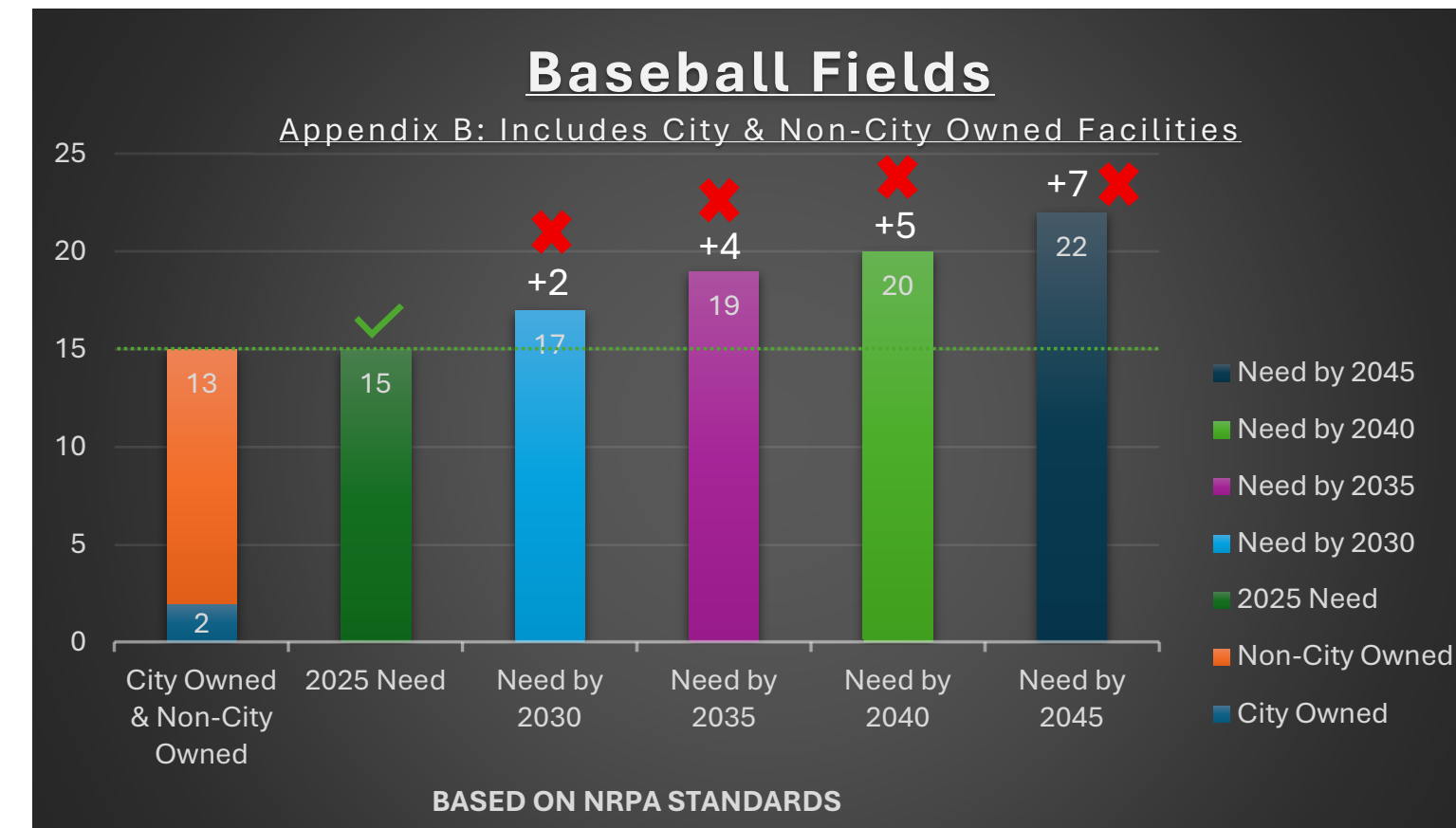

Appendix B - Projected Softball Fields

*Includes city and non-city owned facilities

NRPA Standards: 1 softball field per group of 4,560 residents.

2025: The City's current field inventory is significantly lower than the NRPA Standards for current city population including city and non-city owned facilities.

Leagues and organizations who use facilities: Pflugerville Area Youth Baseball And Softball (PAYBAS)
Age levels who use facilities: 4-14 year olds

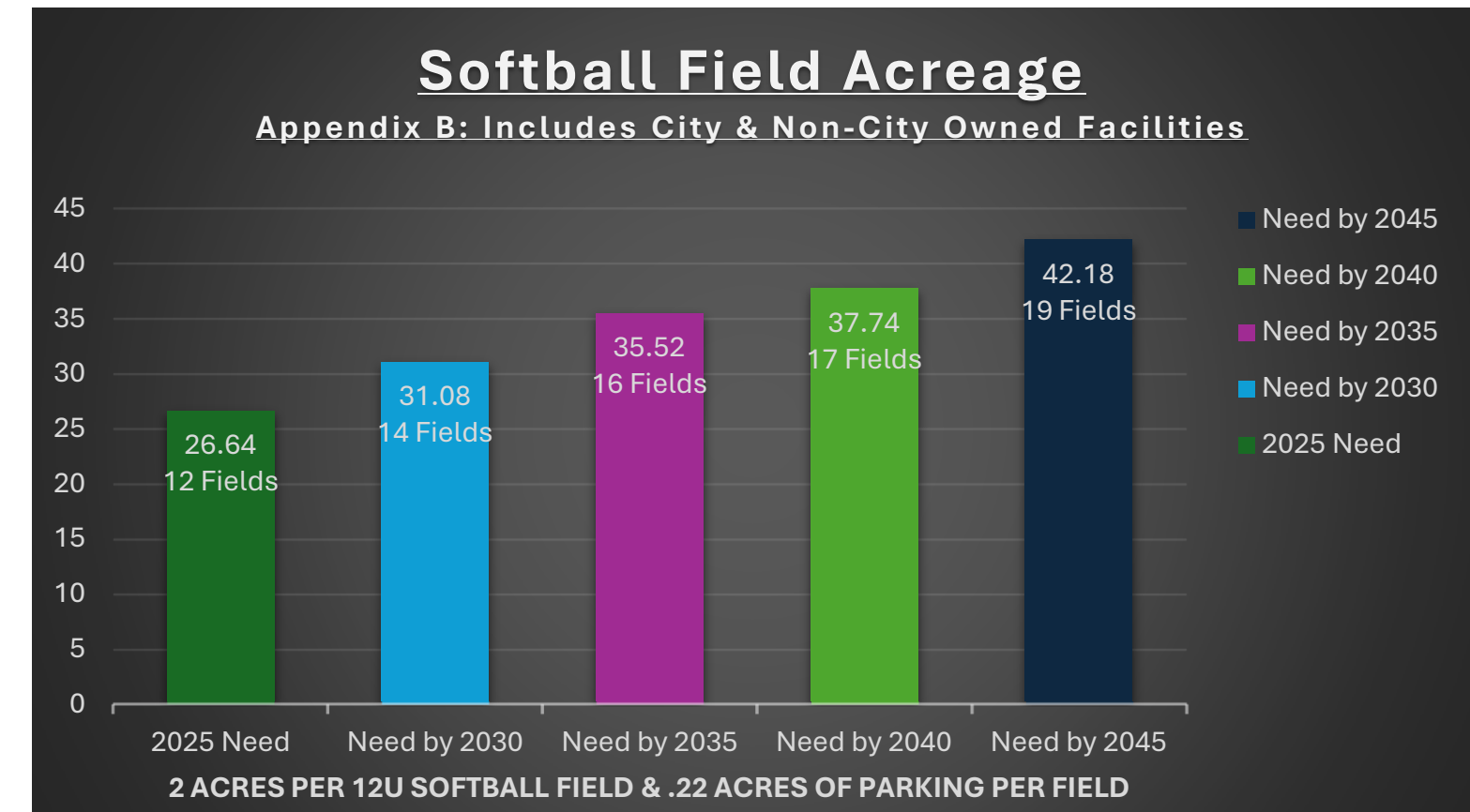
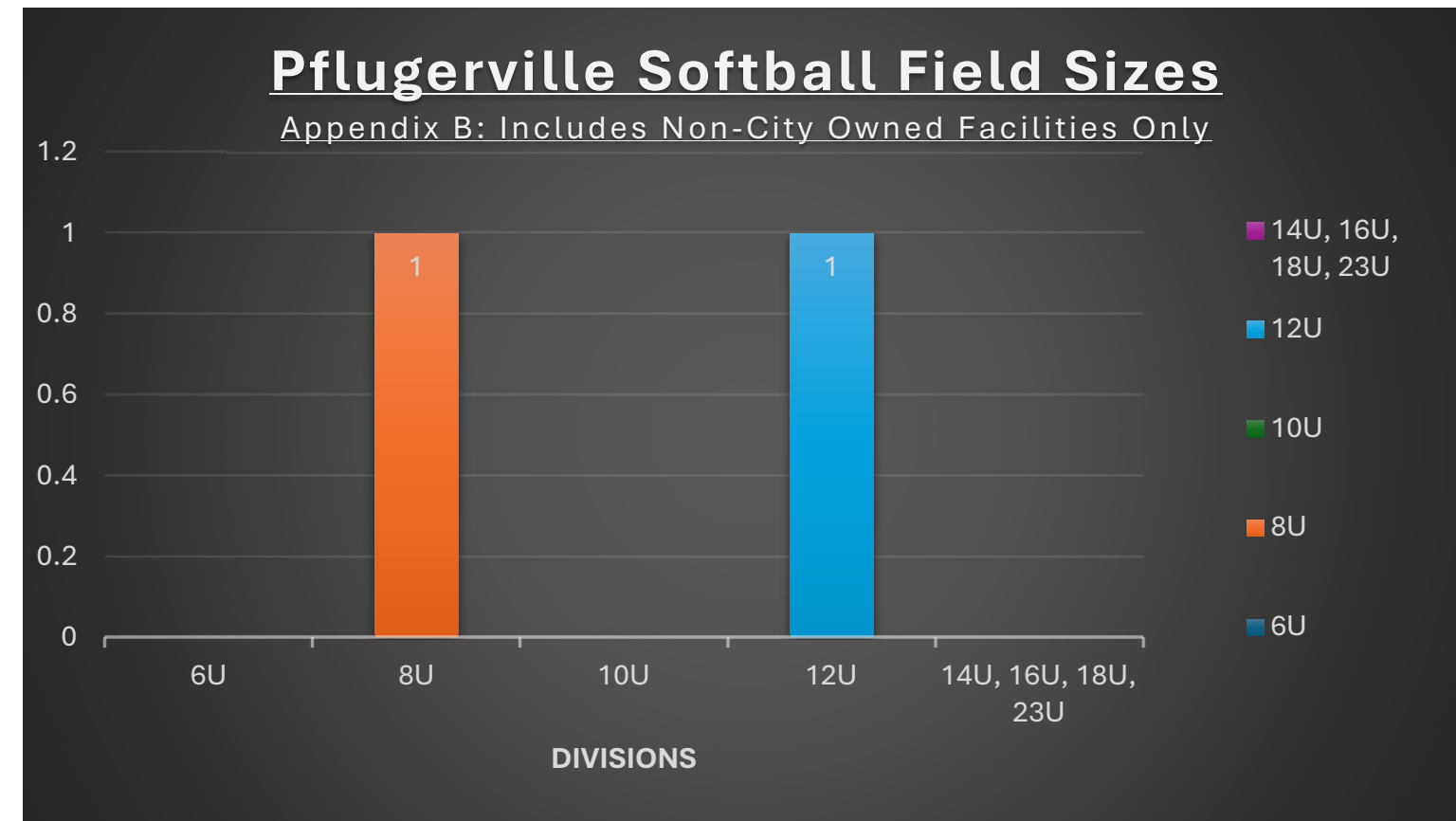
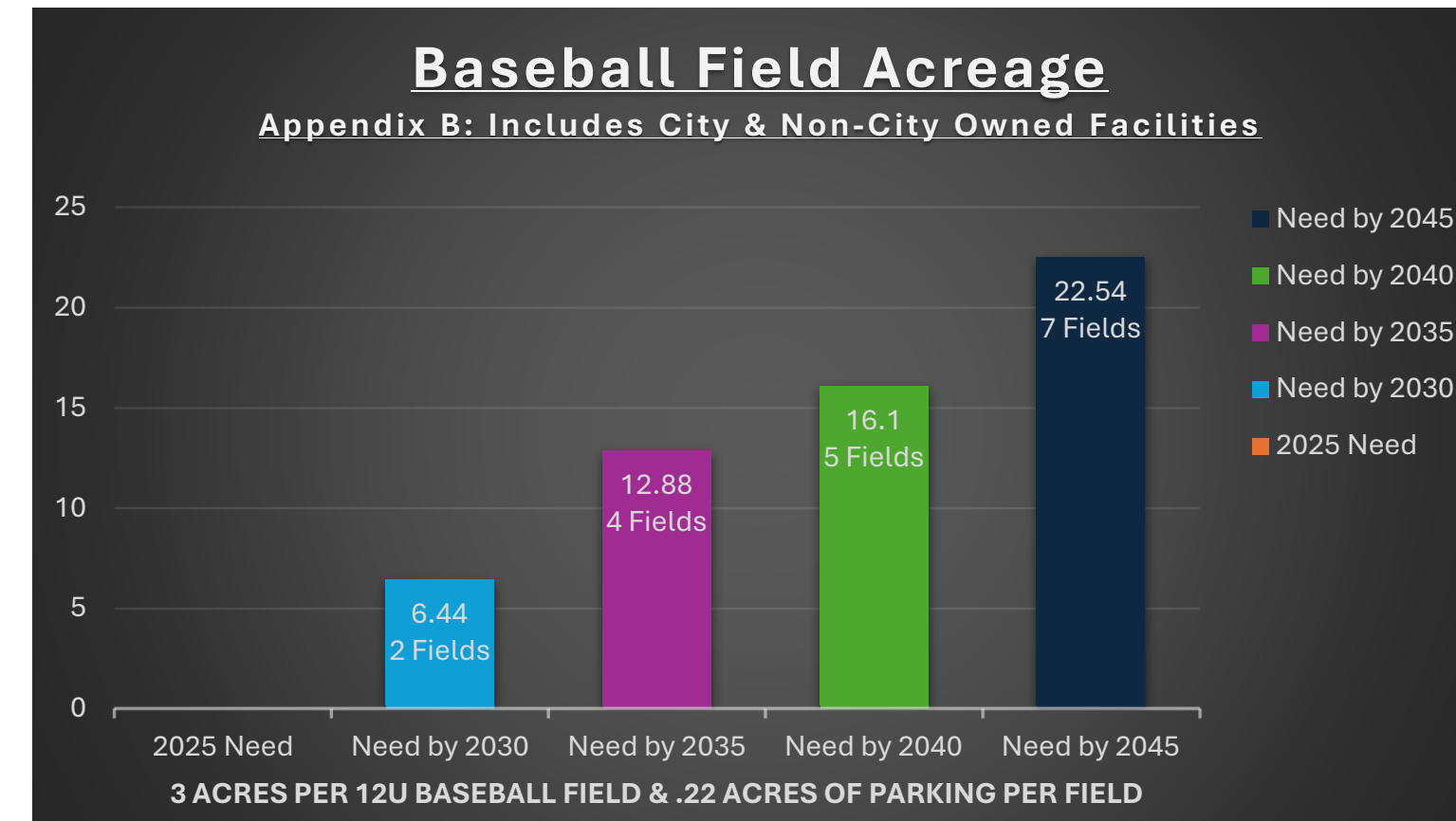
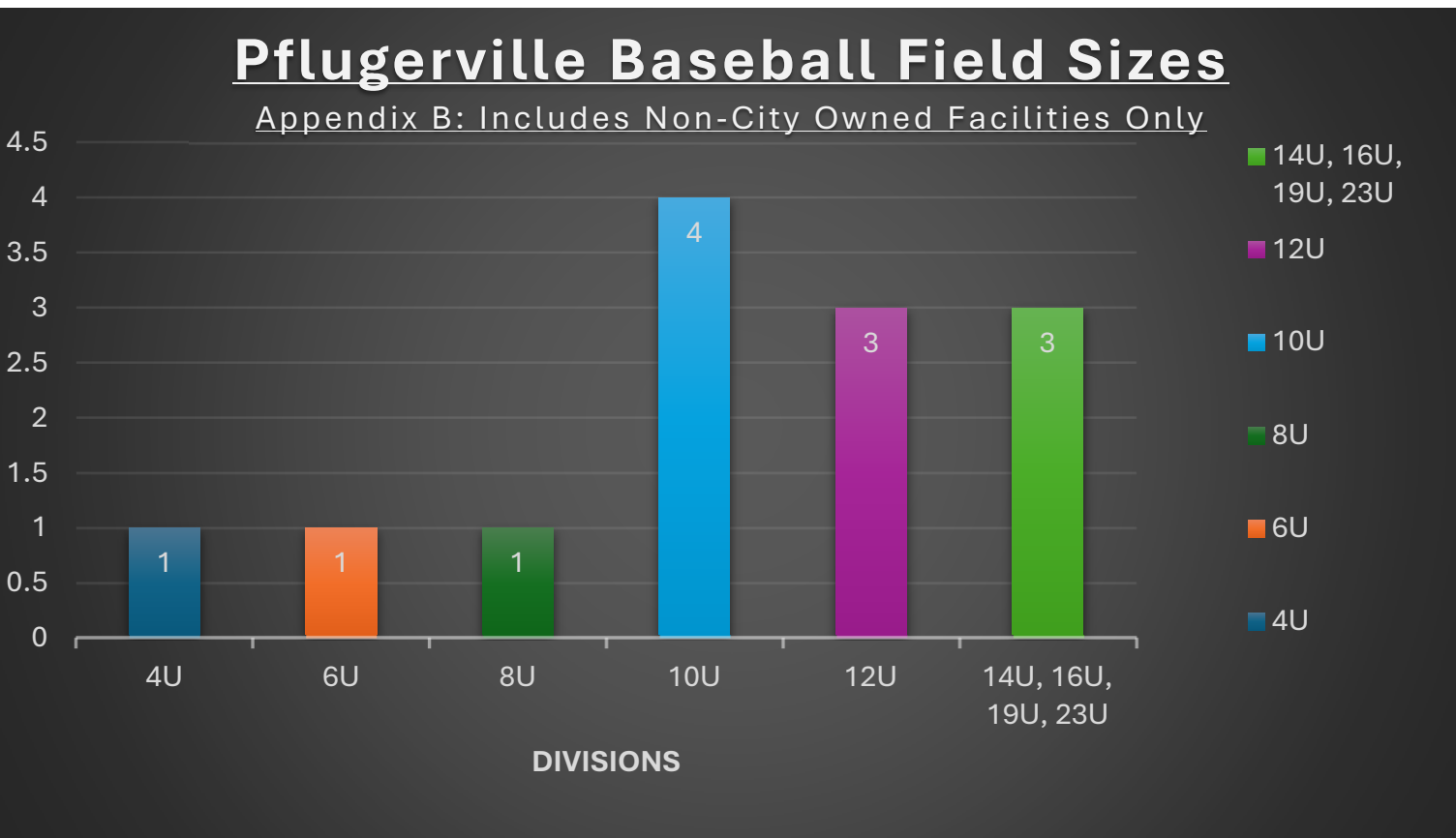
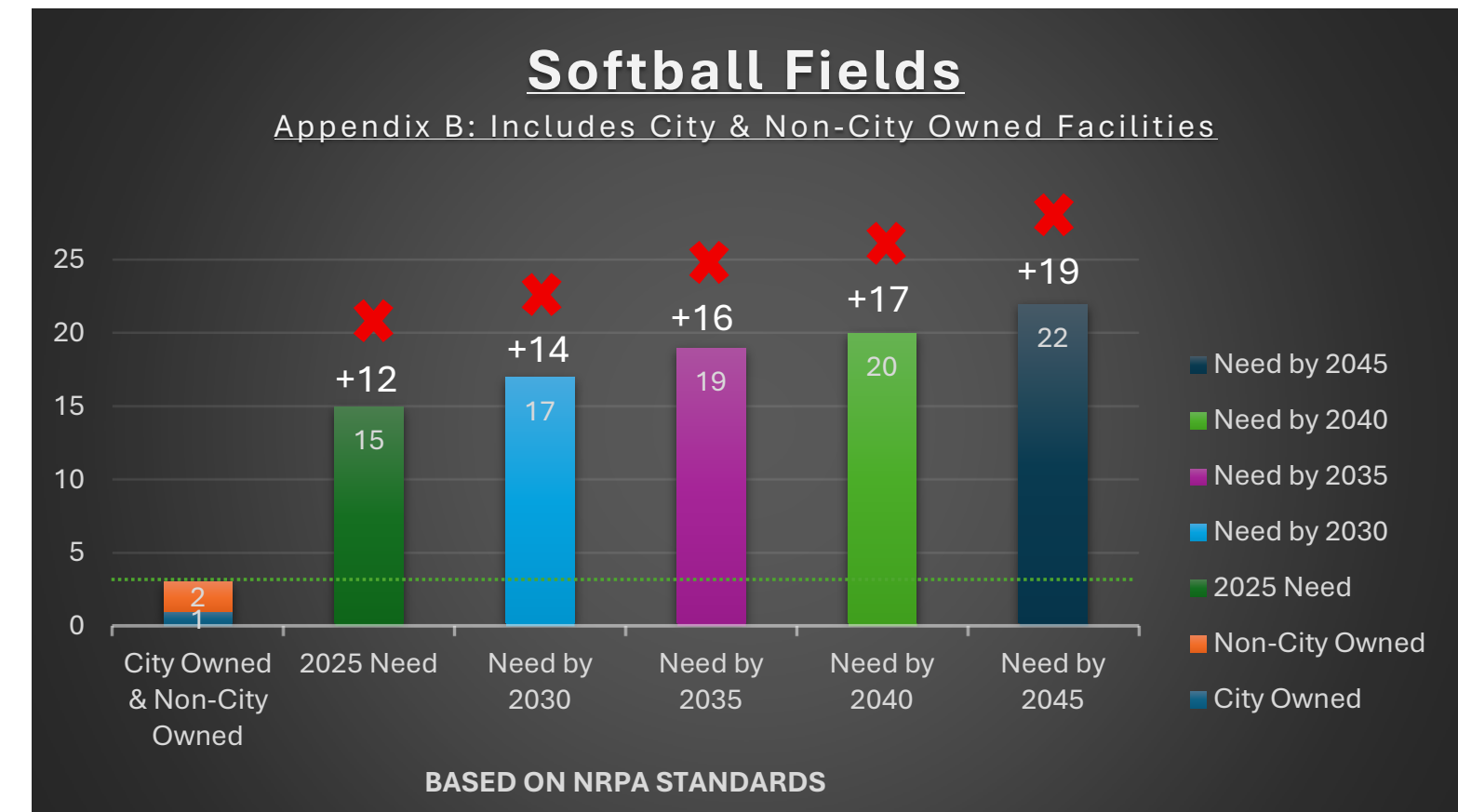

*Reference Appendix C for Northeast Metropolitan Park Fees

*Reference Appendix C for Northeast Metropolitan Park Fees

Appendix B - Projected Disc Golf Courses

*Includes city and non-city owned facilities

NRPA Standards: 1 disc golf course per group of 56,150 residents.

2025: Needs are currently met including city and non-city owned facilities based on NRPA Standards considering the 2025 population.

Leagues and organizations who use facilities: Professional Disc Golf Association (PDGA), Las Basuras, Turcotte's, TFG Disc Golf

Age levels who use facilities: All ages



Appendix B - Projected Rectangular Fields

*Includes city and non-city owned facilities

NRPA Standards: 1 rectangular field per group of 4,659 residents.

2025: The City's current field inventory is lower than the current NRPA Standard for city and non-city owned facilities.

Leagues and organizations who use facilities: Pflugerville Force Youth Football, i9 Sports, Austin Ultimate

Age levels who use facilities: All ages

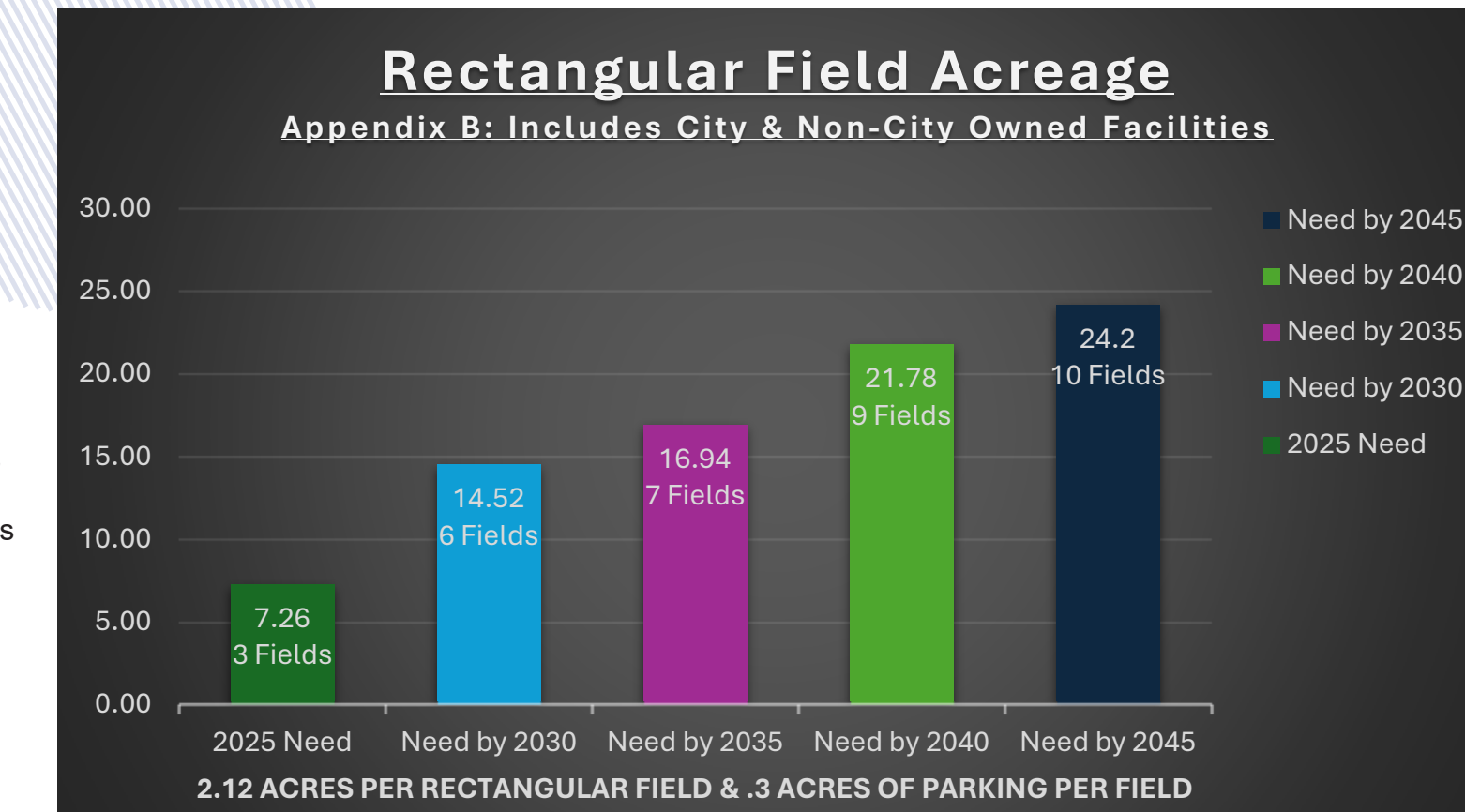
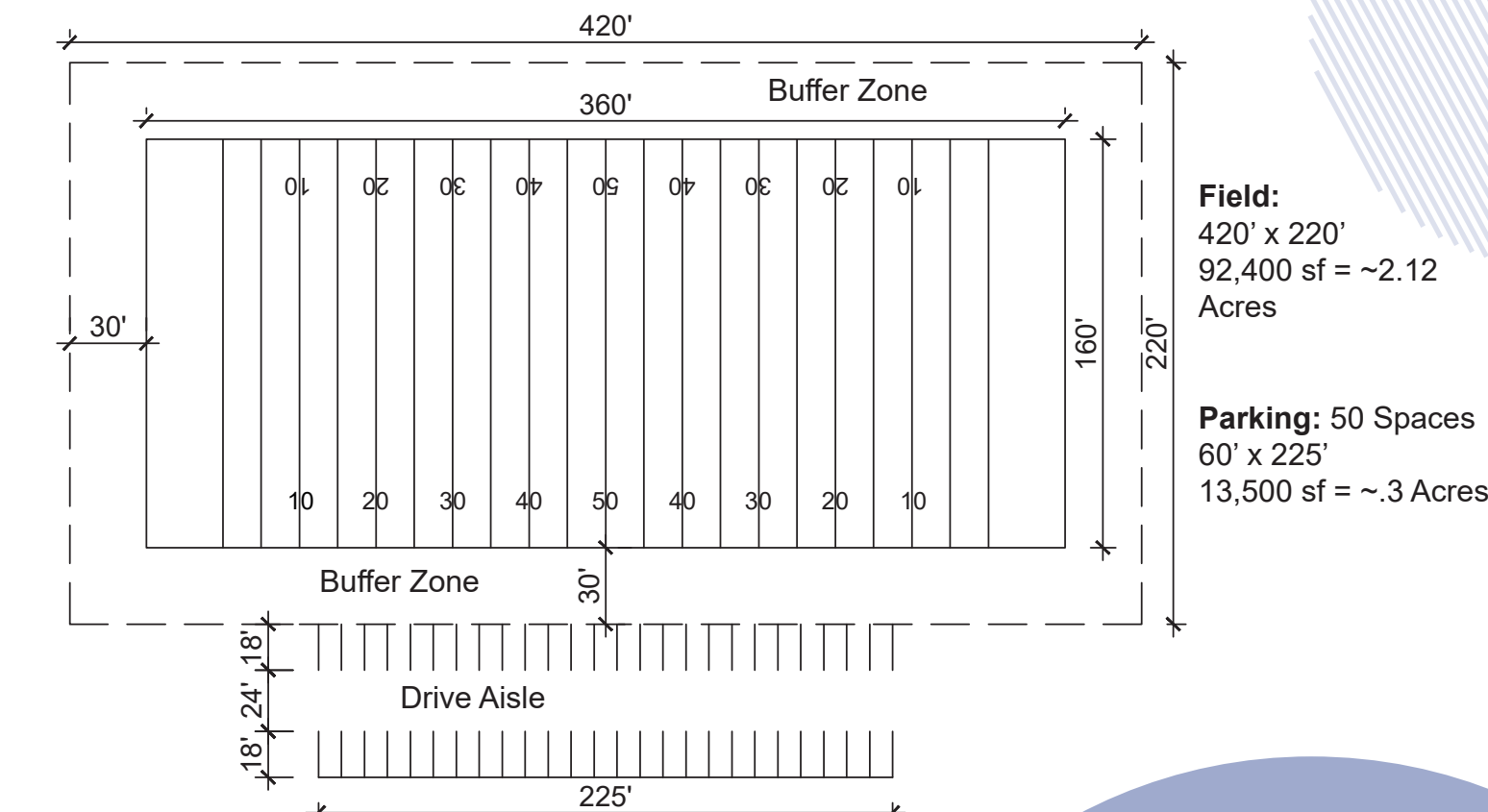
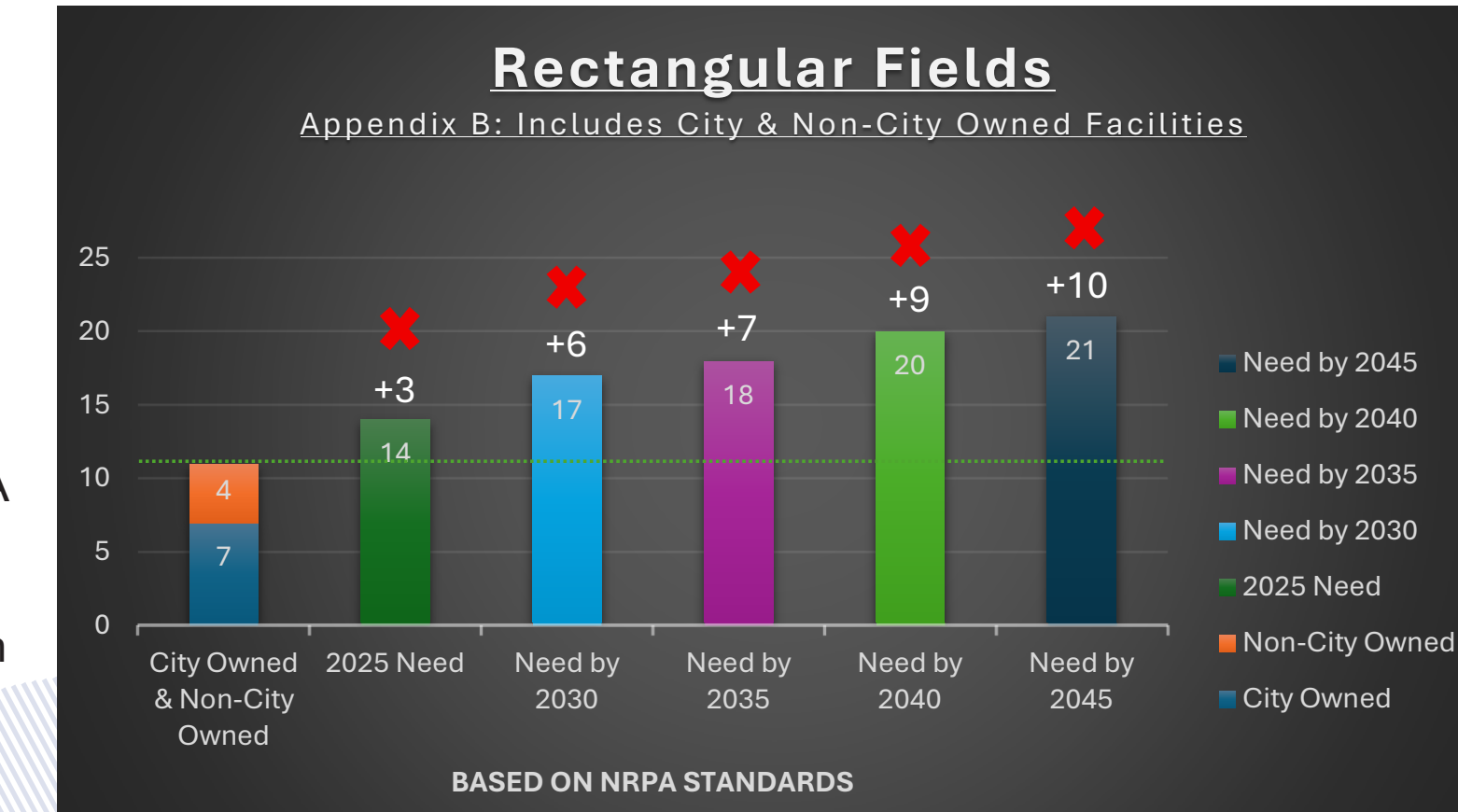

*Reference Appendix C for Northeast Metropolitan Park Fees

Appendix B - Projected Pickleball Courts

*Includes city and non-city owned facilities

NRPA Standards: 1 pickleball court per group of 8,592 residents

2025: Needs are currently met when considering city and non-city owned facilities.

Leagues and organizations who use facilities: Pickleheads, Pickleball Pflugerville, Ladder League

Age levels who use facilities: All ages

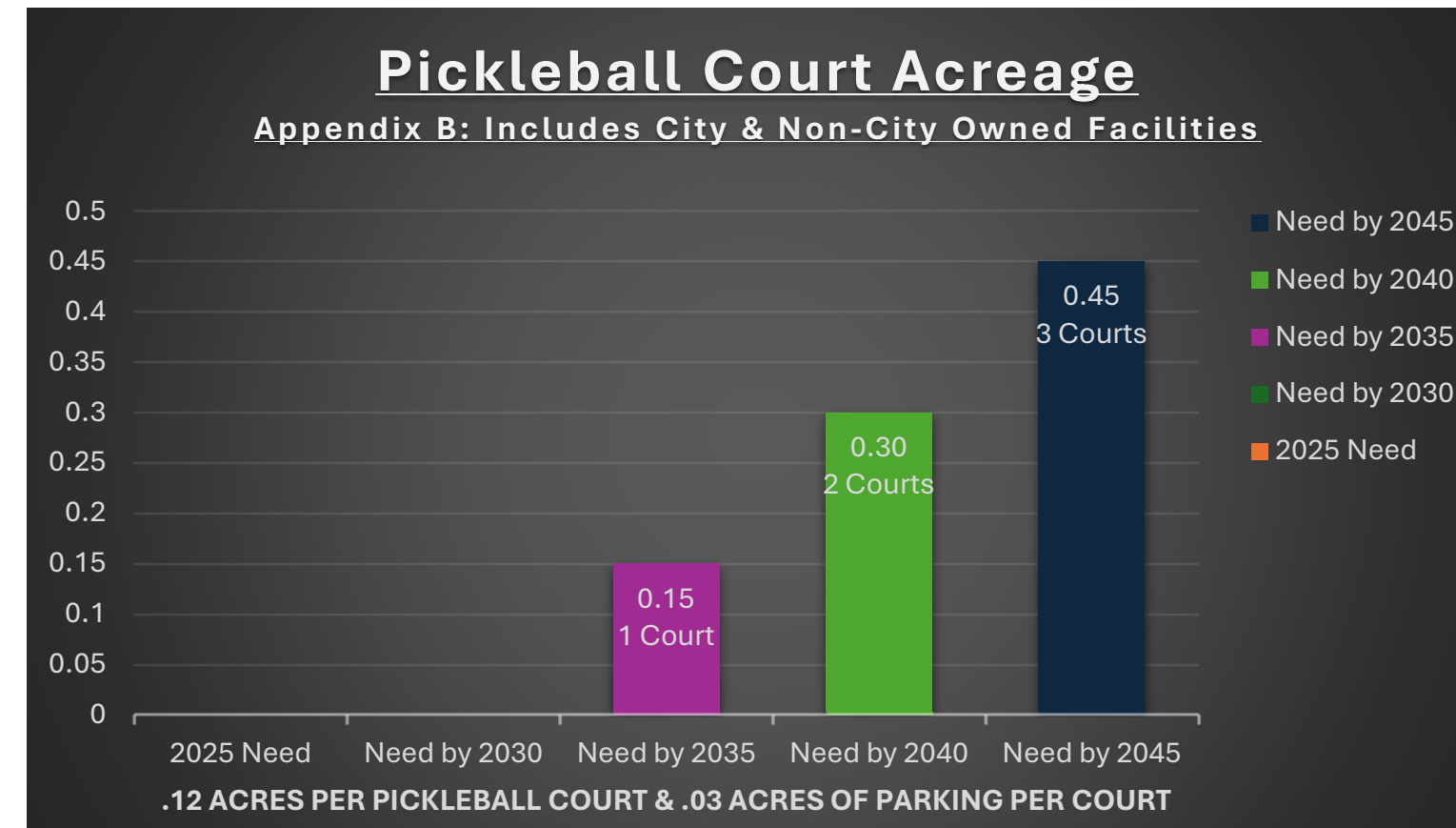
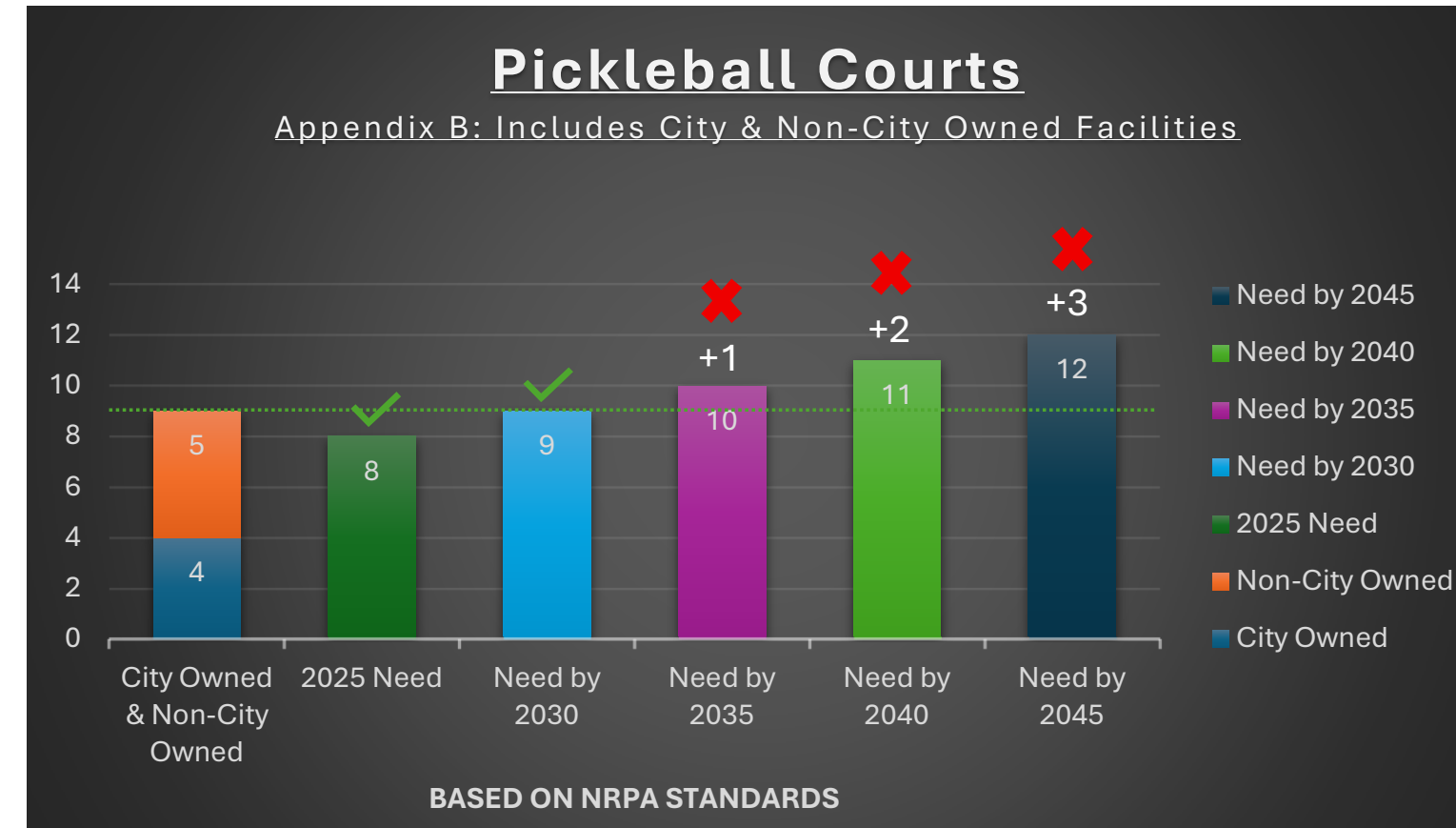
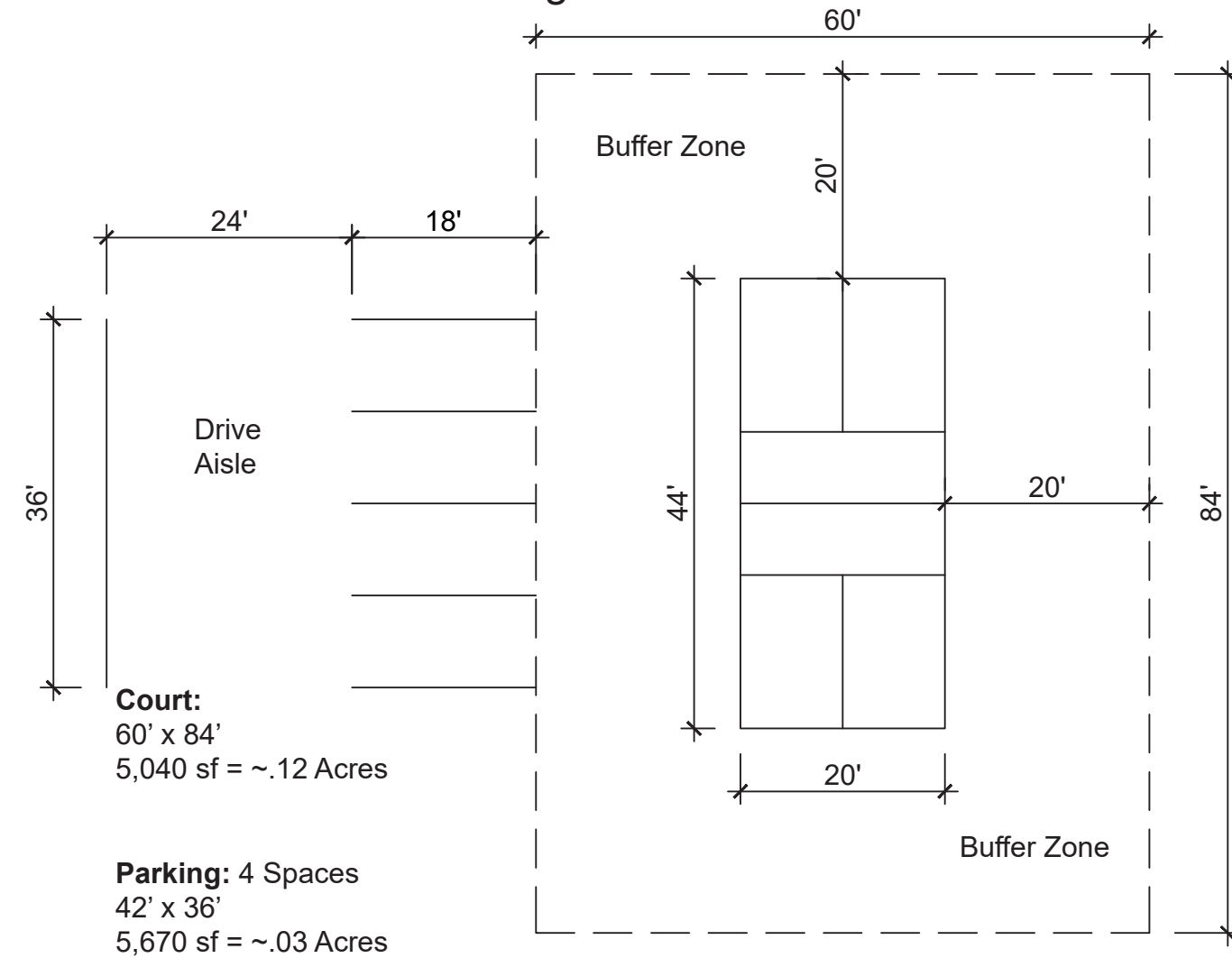

Appendix B - Projected Skate Parks

*Includes city and non-city owned facilities

NRPA Standards: 1 skate park per group of 61,384 residents.

2025: Needs are currently met when considering city and non-city owned facilities.

Leagues and organizations who use facilities: N/A

Age levels who use facilities: All ages

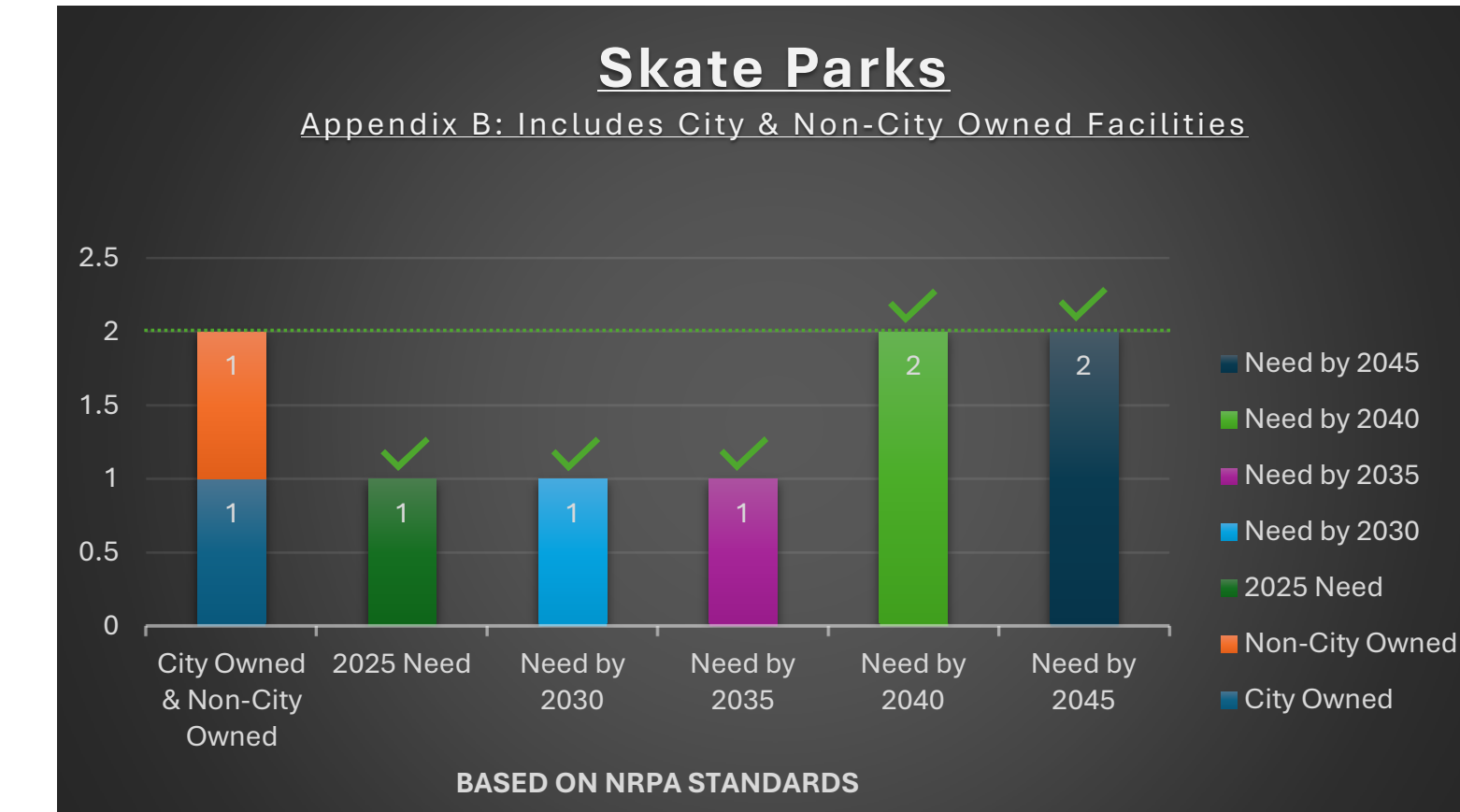

Appendix B - Projected Soccer Fields

*Includes city and non-city owned facilities

NRPA Standards: 1 soccer field per group of 4,659 residents.

The graph to the right uses an 18U, 11v11 as the basis for field size due to existing demand and age demographics of the city.

2025: Needs are currently met when considering city and non-city owned facilities.

Leagues and organizations who use facilities: Pflugerville Area Youth Soccer League (PAYSL), Capital City, One World Soccer, Muslim Youth League of Austin (MYLA), Austin Sports and Social Club (ASSC), Mortega FC

Age levels who use facilities: 3-19 year olds

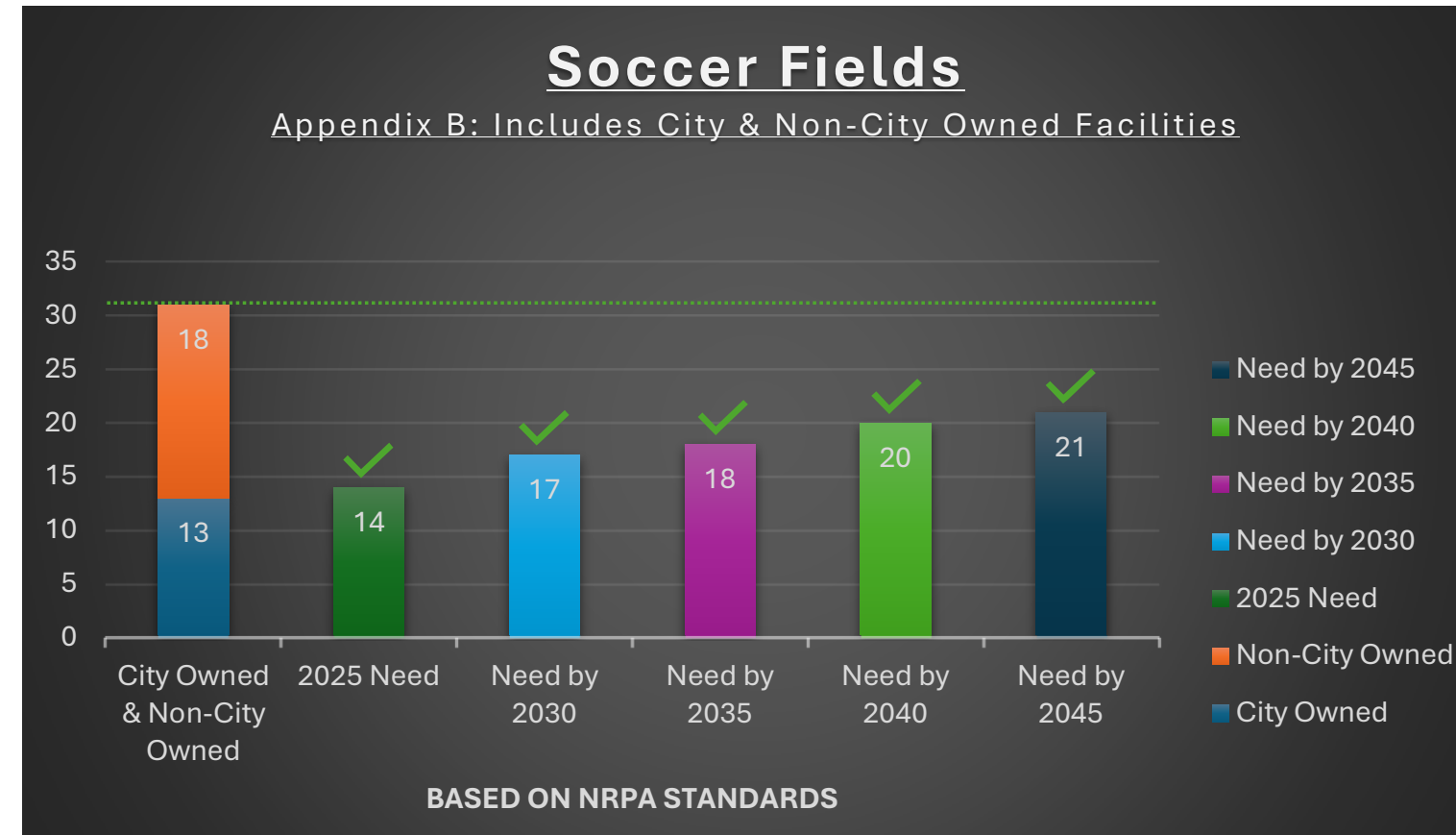

Appendix B - Projected Tennis Courts

*Includes city and non-city owned facilities

NRPA Standards: 1 tennis court per group of 5,818 residents.

2025: Needs are currently met when considering city and non-city owned facilities.

Leagues and organizations who use facilities: Austin Tennis League, Capital Area Tennis Association (CATA), Junior Team Tennis (JTT)

Age levels who use facilities: 6-18 year olds

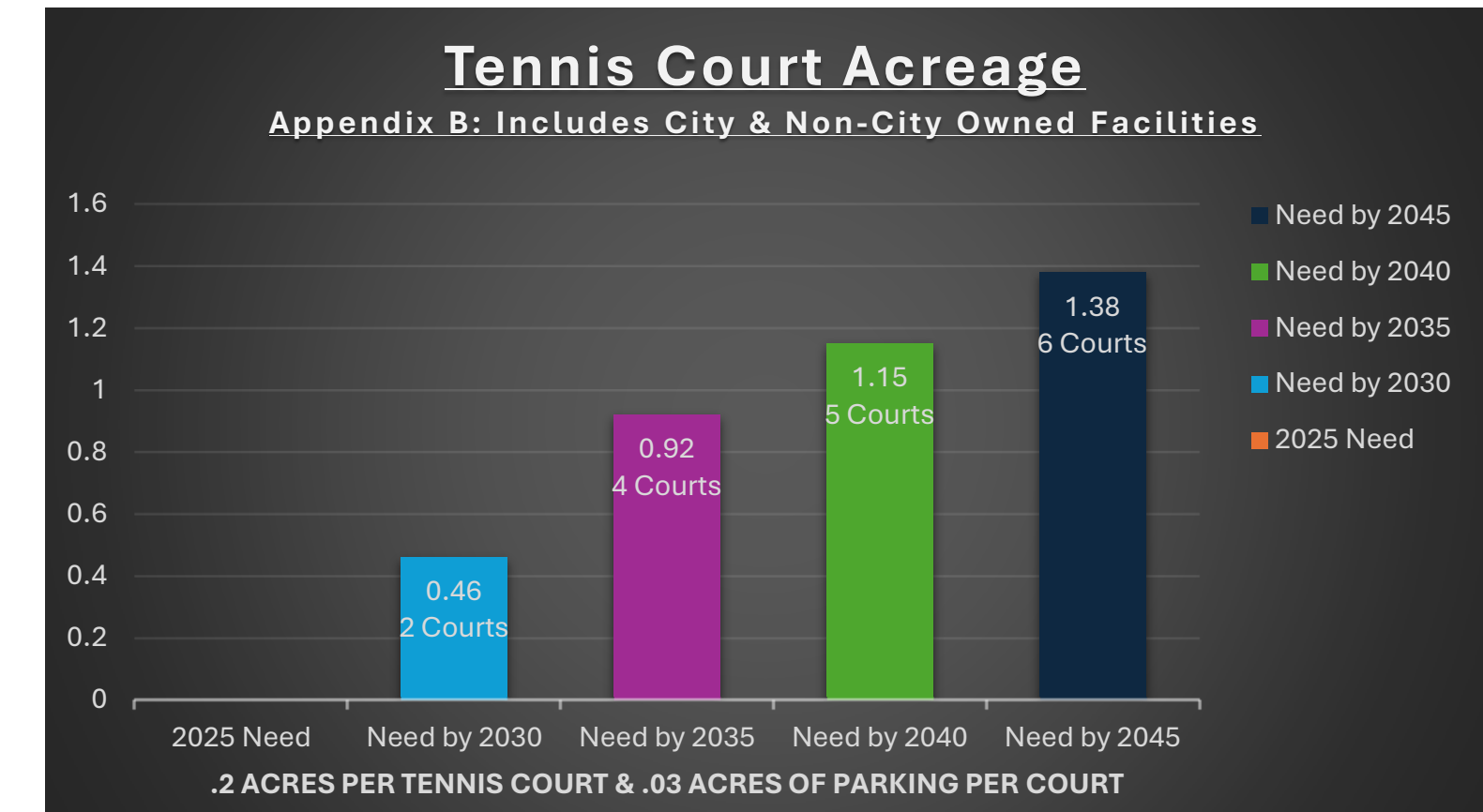
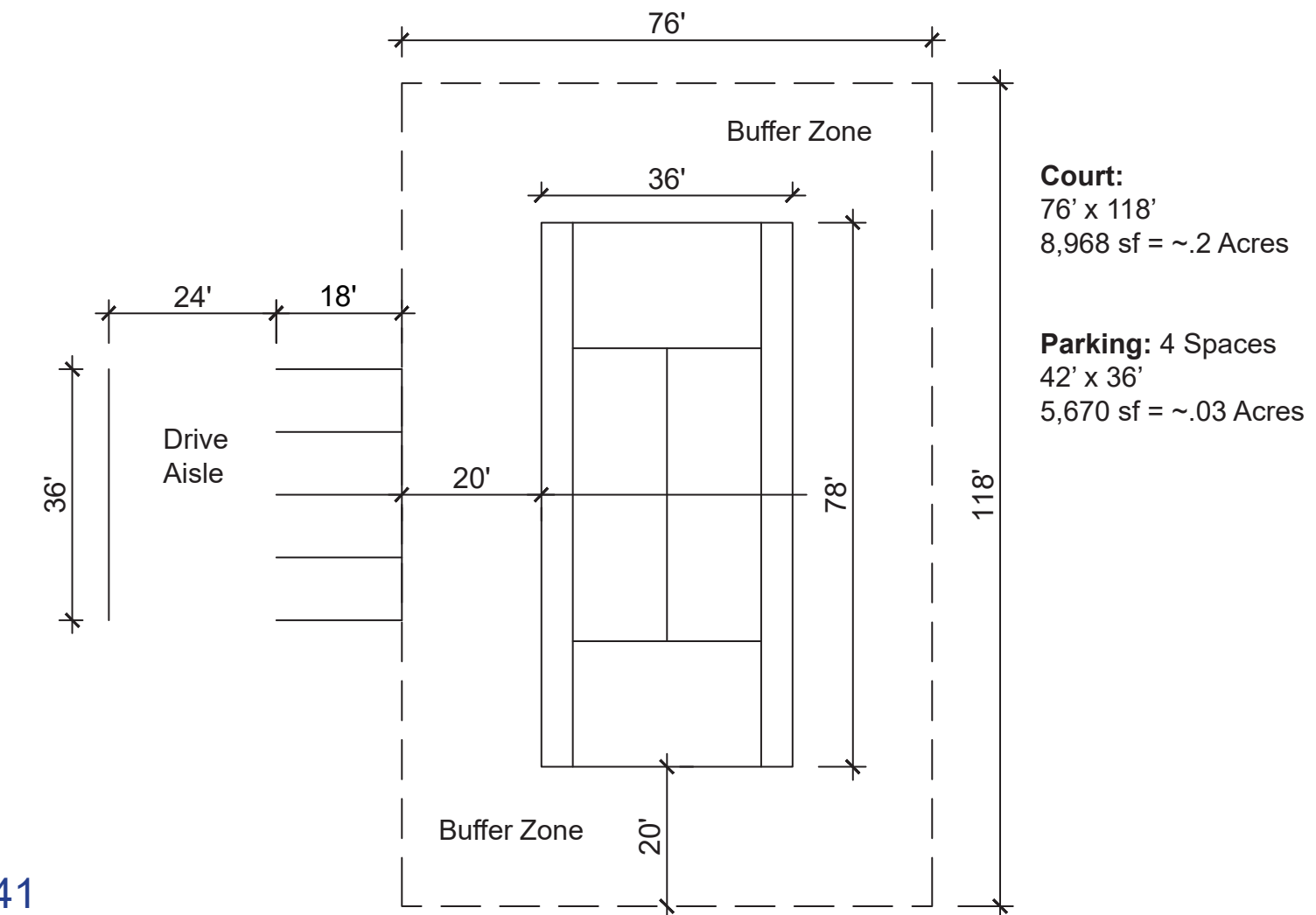
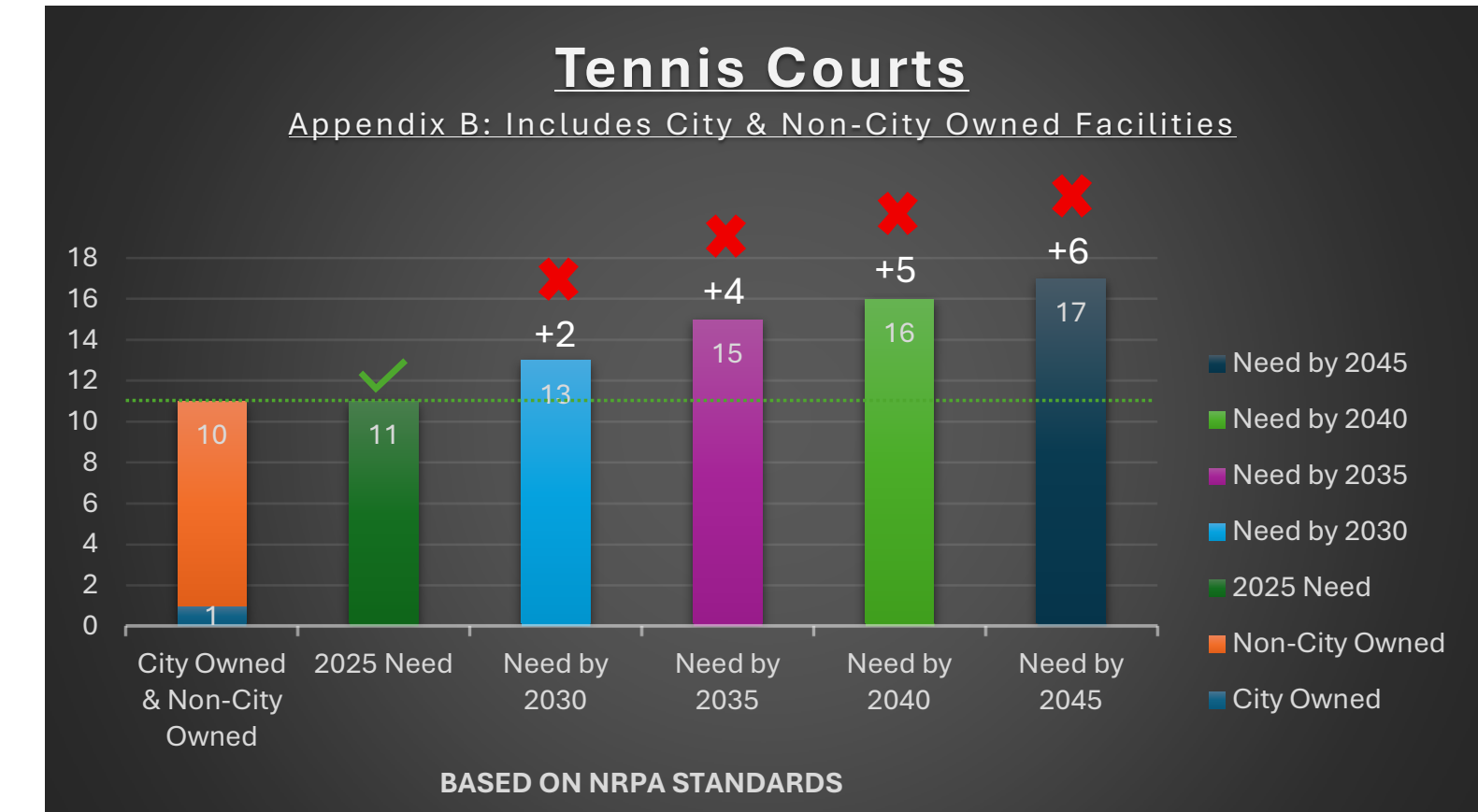

*Reference Appendix C for Northeast Metropolitan Park Fees

Appendix B - Projected Volleyball Courts

*Includes city and non-city owned facilities

NRPA Standards: 1 volleyball court per group of 29,214 residents.

2025: Needs are currently met when considering city and non-city owned facilities.

Leagues and organizations who use facilities: i9 Sports, Empower Juniors, Austin Sports and Social Club (ASSC)

Age levels who use facilities: 7-14 year olds

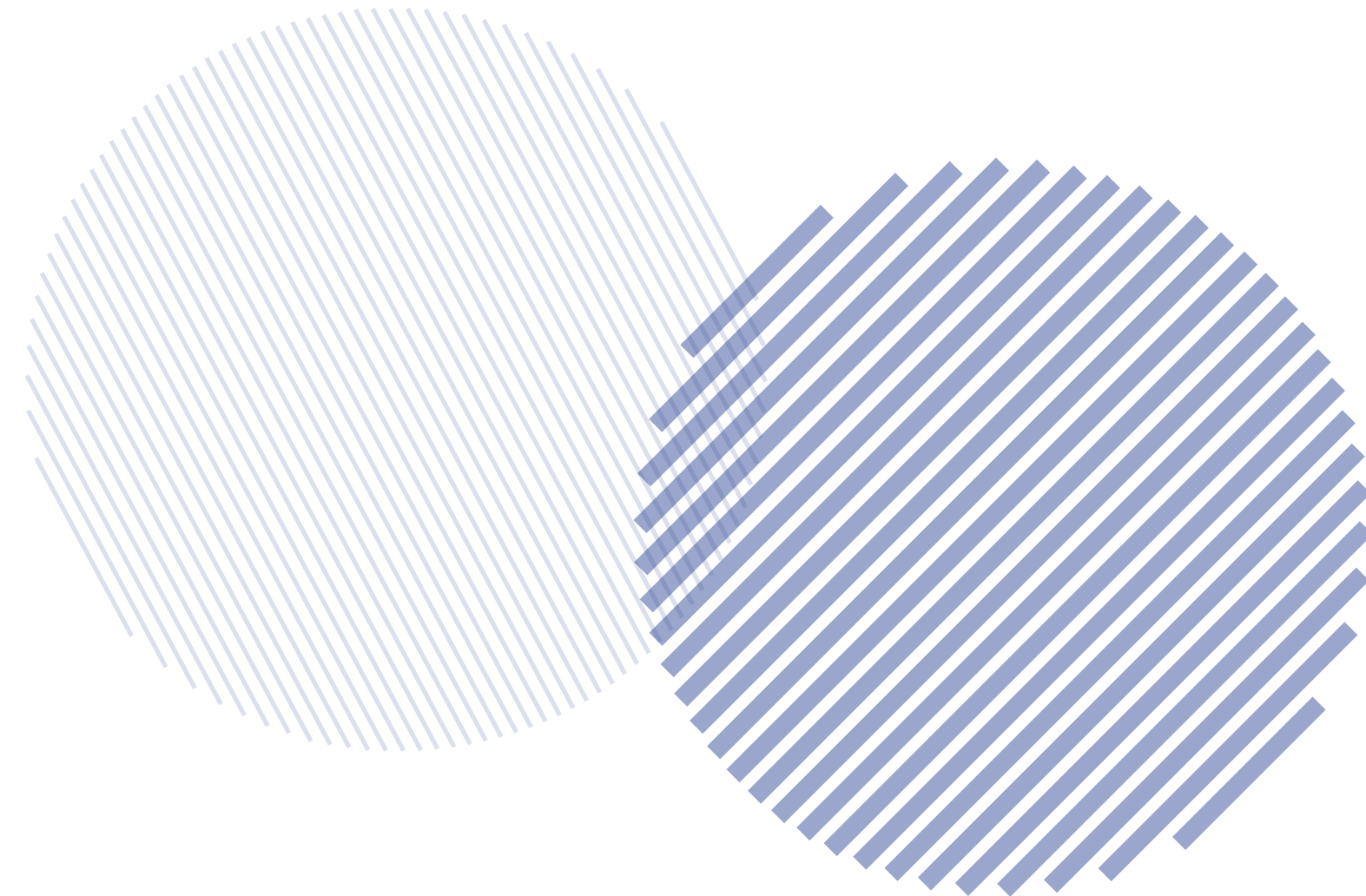
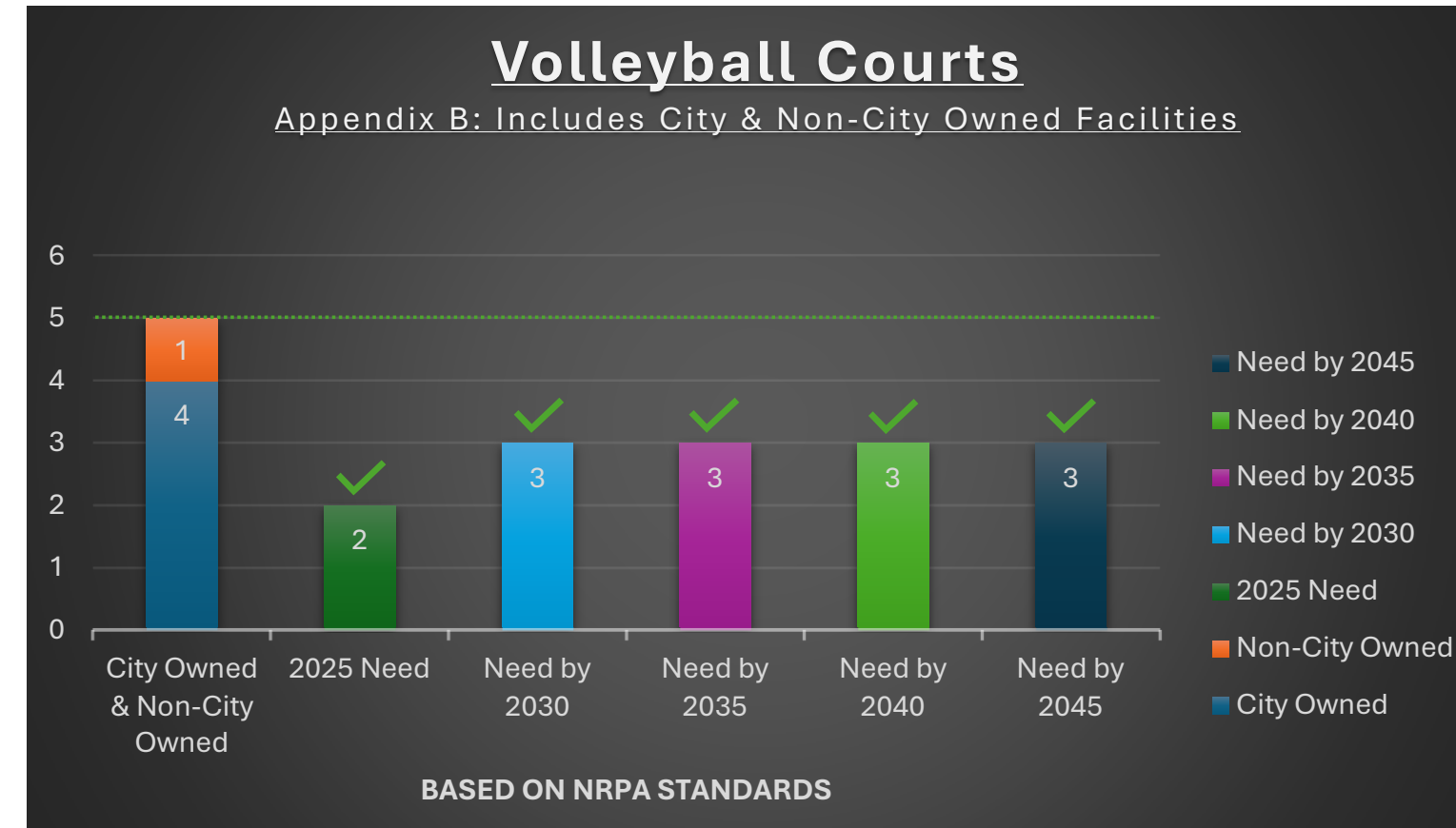

Appendix C - 2025 Park Property Inventory

Pflugerville 1849 Park



Blackhawk Park



Appendix C - 2025 Park Property Inventory

Pflugerville Bohl's Park



Pflugerville Cambridge Heights Park



Appendix C - 2025 Park Property Inventory

Pflugerville Central Park at Falcon Pointe



Pflugerville Geneva's Park

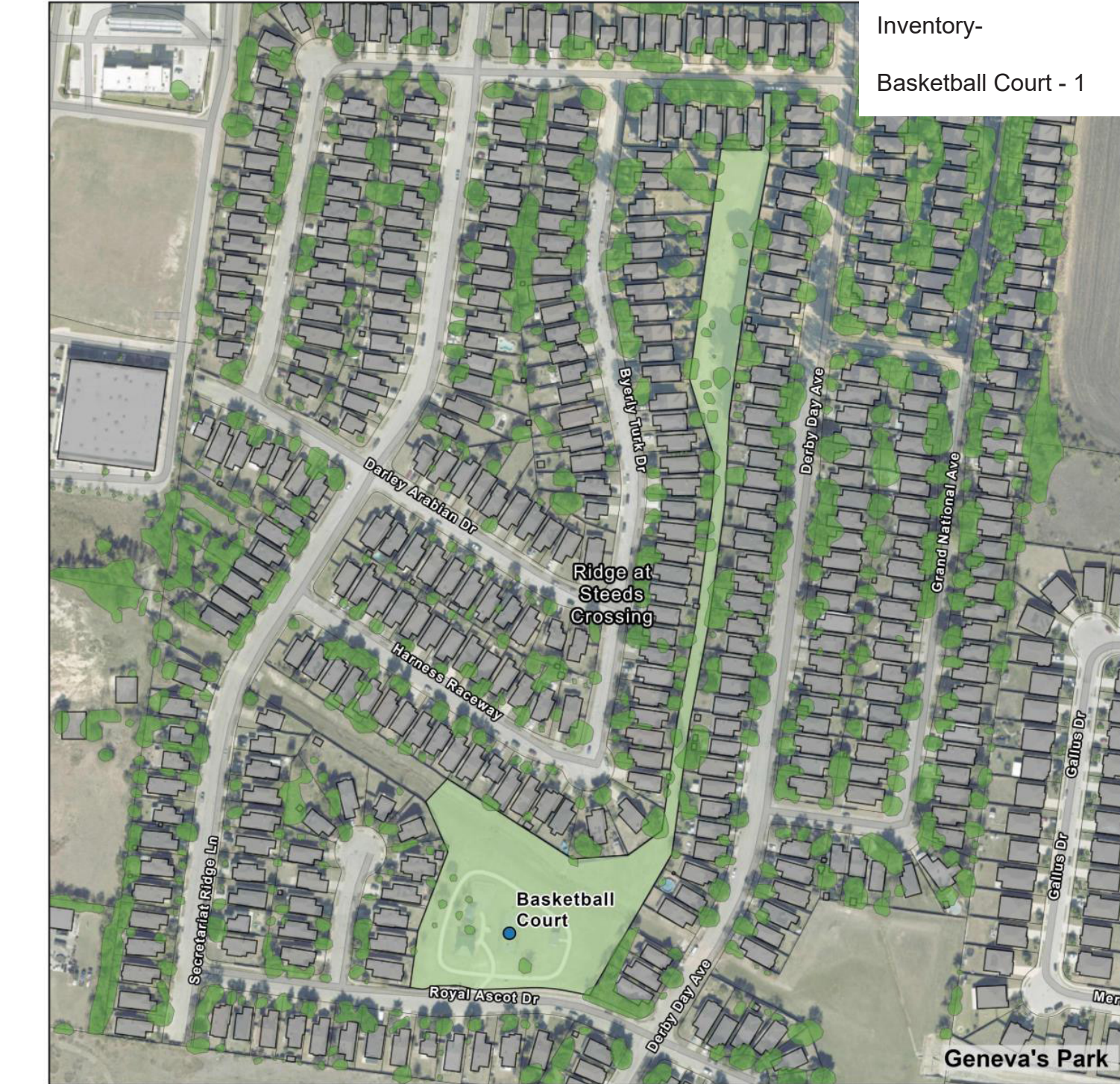

Appendix C - 2025 Park Property Inventory

Pflugerville Heritage Park



Inventory-
Basketball Court - 1
Volleyball Court - 1

Pflugerville Moose Park



Inventory-
Basketball Court - 1

Appendix C - 2025 Park Property Inventory

Travis County Northeast Metropolitan Park



Inventory-
Baseball Field - 8
Multi-Use Field - 4 (18U)
Soccer Field - 14 (18U)
Tennis Court - 2
Pickleball Court - 2
Basketball Court - 1
Skate Park - 1
Cricket Ground - 1

Northeast Metropolitan Park Fees

Baseball Field Pricing	
Type	Cost
Reservation Fee	\$5 per Field per Hour
Field Usage - General	\$6 per Field per Hour
Field Usage - Non-Profit Youth with 501(c)(3)	No Charge
Lights	\$20 per Hour (Additional \$5 per 15 Minutes)
Field Preparation (Set-up and Lining)	\$35 per Field per Day
Tournament/Special Events	\$10 per Field per Hour Additional

Soccer Field Pricing	
Type	Cost
Synthetic Soccer Field - Reservation Fee (Monday - Friday 5:00pm-10:00pm, Saturday - Sunday, 8:00am - 10:00pm) (General and Non-Profit groups)	\$38 per Field per Hour
Natural Grass Field - Weekday Reservation Fee	\$5 per Field per Hour
Synthetic Soccer Field - Reservation Fee, Off-Peak Hours (Monday - Friday 8:00 am to 5:00 pm) (General and Non-Profit groups)	\$28 per Field per Hour
Natural Grass Field - Weekend Reservation Fee (includes standard soccer lining)	\$10 per Field per Hour
Field Usage - General	\$6 per Field per Hour
Field Usage - Non-Profit Youth with 501(c)(3)	No Charge
Lights	\$30 per Hour (Additional \$7.50 per 15 Minutes)
Field Preparation (Set-up and Lining)	\$35 per Field per Day
Tournament/Special Events	\$10 per Field per Hour Additional

Multi-Use Field Pricing	
Type	Cost
Weekday Reservation Fee	\$5 per Field per Hour
Weekend Reservation Fee	\$10 per Field per Hour
Field Usage - General	\$6 per Field per Hour
Field Usage - Non-Profit Youth with 501(c)(3)	No Charge
Field Preparation (Set-up and Lining)	\$35 per Field per Day
Tournament/Special Events	\$10 per Field per Hour Additional

Cricket Field Pricing	
Type	Cost
Reservation Fee	\$5 per Field per Hour
Field Usage - General	\$6 per Field per Hour
Field Usage - Non-Profit Youth with 501(c)(3)	No Charge
Field Preparation (Set-up and Lining)	\$35 per Field per Day
Tournament/Special Events	\$10 per Field per Hour Additional

Concession Pricing	
Type	Cost
Travis County Resident Reservation Fee (Non-Refundable)	\$10
Non-Travis County Resident Reservation Fee (Non-Refundable)	\$30
Concession Building - General	\$150 per Building per Day
Deposit (Refundable)	\$50
Concession Building - Non-Profit Youth with 501(c)(3) Weekdays	\$20 per Building per Day
Concession Building - Non-Profit Youth with 501(c)(3) Weekends and Holidays	\$50 per Building per Day

Temporary Concession Permit Pricing	
Type	Cost
Weekday Rental	\$20 per Day
Weekend/Holiday Rental	\$40 per Day

Appendix C - 2025 Park Property Inventory

Pflugerville Pfluger Park



Pflugerville Elementary School (PAYBAS)



Appendix C - 2025 Park Property Inventory

Pflugerville High School



Pflugerville Recreation Center



Appendix C - 2025 Park Property Inventory

Pflugerville Royal Pointe Park



Inventory-
Basketball Court - 1

Royal Pointe Park

Sip & Smash Social



Inventory-
Pickleball Court - 3

Sip & Smash Social

Appendix C - 2025 Park Property Inventory

Pflugerville Stone Hill Park



Inventory-
Rectangular Field - 1
Multi-Use Court - 1

Stonehill Park

Stoney Creek Park



Inventory-
Disc Golf Course - 1
Volleyball Court - 1

Stoney Creek Park

Appendix C - 2025 Park Property Inventory

Pflugerville Vine Creek Park



Pflugerville Wells Point Sports Park



Appendix C - 2025 Park Property Inventory

Pflugerville Windermere Park



Pflugerville Pfennig Park



Appendix D - Public Engagement Notes

Parkhill

QUESTIONS	STAKEHOLDR INPUT MTG: Pflugerville Athletic Field Feasibility Study
Date: 09/10/2025	STAKEHOLDER NAME: Austin Ultimate

- Stakeholder Contact Information?**
 - Elizabeth Carbajal, President.
- What sport do you play?**
 - Ultimate Frisbee (non-profit), USA Ultimate – Governing Body. Span from San Marcos to Round Rock.
- How many players do you have in your association?**
 - Format Dependent. 300 players in the adult winter league, and 300 youth players/15 middle and high school-based teams.
- What age are your players?**
 - Youth to adults, Legends & Grandmaster/Seniors.
- How many teams?**
 - 6 college teams, 15 school teams, 3 youth clubs, and 8 adult clubs.
- Do you know how many of your players are residents of Pflugerville?**
 - 10% of league players live in or around Pflugerville.
- Where do you play games in Pflugerville?**
 - NE Metro, but no city owned facilities.
- Where do you play games in the greater Austin area?**
 - Round Rock Multi-purpose for large events; smaller events at Huns Rugby Ranch, Eanes ISD., and Zilker Park. ISD locations cause more problems.
- Where do you practice in Pflugerville?**
 - N/A.
- Where do you practice in the greater Austin area?**
 - Some teams rent space for evenings and camps/clinics. Any available space and decided by the teams.
- Is your association growing?**
 - Yes, trying to. Youth and adults are slow but steady.
- Is there a certain demographic that is growing more or faster than others?**
 - Adult groups are growing a bit more than youth.
- What size of fields do you play on?**
 - Standard size is 40yds x 110yds (College/High School), 2 fields per soccer field.
- Do you prefer natural grass or synthetic turf?**
 - Love well maintained natural grass but would utilize synthetic more.

Appendix D - Public Engagement Notes

Parkhill

QUESTIONS	STAKEHOLDR INPUT MTG: Pflugerville Athletic Field Feasibility Study
Date: 09/11/2025	STAKEHOLDER NAME: Pflugerville Force Youth Football Association

- Stakeholder Contact Information?**
 - Richard and Laura Clark, Founders and have done youth sports for 12yrs. Previously town and country, then Round Rock McNeil HS, now in Pflugerville.
- What sport do you play?**
 - Tackle football, flag football, and cheer. Maybe baseball in the future, but there is a lack of fields. PFYFA is part of the Central Texas Youth Football League (CTYFL). Tackle football is not offered by many other organizations.
- How many players do you have in your association?**
 - 220 players.
- What age are your players?**
 - 4-12. Offer programs such as cheer, flag, and tackle.
- How many teams?**
 - 10 teams total for football and 1 cheer team.
- Do you know how many of your players are residents of Pflugerville?**
 - 90% in Pflugerville but players come from Hutto, Manor, Cedar Park, and Round Rock.
- Where do you play games in Pflugerville?**
 - Weiss HS (\$12-16K per season). Field costs are very high.
- Where do you play games in the greater Austin area?**
 - Kyle, Bastrop, Leander, Georgetown, and Hutto.
- Where do you practice in Pflugerville?**
 - Kelly Lane Middle School and 1849 Park (fall). 1849 fields are expensive.
- Where do you practice in the greater Austin area?**
 - Kelly Lane Middle School, Lake Pflugerville, moved to 1849 to have lights, NE Metro County Park, and any space they can find with parking.
- Is your association growing?**
 - Yes, 70 players in the first year, 150 last year, and 220 this year and turned some away.
- Is there a certain demographic that is growing more or faster than others?**
 - Even growth across the age groups.
- What size of fields do you play on?**
 - 45 yd can play 2 games on a 100 yd field. Full size fields are needed.
- Do you prefer natural grass or synthetic turf?**
 - Turf is ideal. Safer and better for weather.

Appendix D - Public Engagement Notes

Parkhill

Page 2

QUESTIONS Date: 09/12/2025	STAKEHOLDR INPUT MTG: Pflugerville Athletic Field Feasibility Study STAKEHOLDER NAME: Austin TapedBall Cricket League
--------------------------------------	--

- Stakeholder Contact Information?**
 - Chiranjeevi, atcl_registration@yahoo.com
- What sport do you play?**
 - Tape Ball Cricket, 10+ yrs in Austin
 - Tape ball cricket is an informal, improvised version of cricket played with a tennis ball wrapped in electrical tape. Originating in Pakistan, this modification gives the ball more weight and a smoother surface, increasing its speed and ability to swing after bouncing. It's a faster, simpler, and safer alternative to traditional hard-ball cricket, often played in streets and open grounds by smaller teams with shorter matches and tailored rules.*
- How many players do you have in your association?**
 - 300 players.
- What age are your players?**
 - Primarily adult.
- How many teams?**
 - 10 teams, 30 players per team. 4 women's teams in the spring, 45 teams previously.
- Do you know how many of your players are residents of Pflugerville?**
 - +/- 150 players.
- Where do you play games in Pflugerville?**
 - NE Metro Park, 1 cricket field.
- Where do you play games in the greater Austin area?**
 - Previously Leander, Cedar Park, and Pflugerville.
- Where do you practice in Pflugerville?**
 - Organization at NE Metro Park, but individual teams may practice elsewhere.
- Where do you practice in the greater Austin area?**
 - N/A.
- Is your association growing?**
 - The sport is growing; organization reduced due to available facilities and private facility in Leander – Lonestar Premier Cricket League.
- Is there a certain demographic that is growing more or faster than others?**
 - South Asian and a few European countries.
- What size of fields do you play on?**
 - 60–65 yard radius, need 5 acres for field, buffer, and amenities.

- Do you prefer natural grass or synthetic turf?**
 - Turf is nice but not necessary and it would increase costs.
- What is your greatest need currently?**
 - Multipurpose field with field pitch, lights would be great, and 360 degrees batting cages sized to the pitch in groups at multiple locations, could be multipurpose – used by baseball and cricket. If not, provide the association open land for them to build them.
- Is there anything else you would like to share?**
 - Interested in available tracts within the floodplain for field space. Box Cricket – shrink the field to 60-80', reduce speed of pitched ball, and 30' tall perimeter fence.



Appendix D - Public Engagement Notes

Parkhill

Page 2

QUESTIONS Date: 09/12/2025	STAKEHOLDR INPUT MTG: Pflugerville Athletic Field Feasibility Study STAKEHOLDER: Pflugerville Area Youth Baseball and Softball (PAYBAS)
--------------------------------------	--

- Stakeholder Contact Information?**
 - Traci Dockter, Vice President, traci@paybas.org. Been around since 1979.
- What sport do you play?**
 - Baseball and Softball.
- What league organization are you part of?**
 - PONY Baseball.
- How many players do you have in your association?**
 - Spring 2025 – 362 BB, 103 SB.
 - Fall 2025 – 365 BB, 104 SB.
 - Fall 2024 – 344 BB, 97 SB.
 - Almost recovered from COVID, Softball is declining across the board.
- What age are your players?**
 - Baseball – 4u, 6u, 8u, 10, 12u, 14u.
 - Softball – 6u, 8u, 10u, 12u – 14u has not made a team in 2 years, girls went to Hutto. 12u Hutto girls came to PAYBAS.
 - 4u is coed.
- How many teams?**
 - 44 total teams. Fall – 1 game per week per team, fall games on Saturdays. Spring – 1 game on Saturday and 1 game during the week plus tournaments.
- Do you know how many of your players are residents of Pflugerville?**
 - 80-85% are local. Others from Taylor, Hutto, Manor, Round Rock, and Buda.
- Where do you play games in Pflugerville?**
 - PAYBAS Fields, 701 Immanuel Rd.
- Where do you play games in the greater Austin area?**
 - All over Austin metro. area - Hutto, Bastrop, Austin, Manor, Lexington, and Taylor.
- Where do you practice in Pflugerville?**
 - Practice on game fields and rent space at NE Metro.
- Where do you practice in the greater Austin area?**
 - N/A.
- Is your association growing?**
 - Yes.

- Is there a certain age group that is growing more or faster than others?**
 - 4u, 6u, and 8u are the largest groups.
- What size of fields do you play on?**
 - Multiple ages play on same fields; some fields are dedicated by age.
- Do you prefer natural grass or synthetic turf?**
 - No preference, just affordable fields.
- What is your greatest need currently?**
 - Fields, lighting, scoreboards, batting cages, concessions, and restrooms. All but 2 current fields are lit.
- Is there anything else you would like to share?**
 - Applying for grant (PCDC) for fencing, scoreboards, septic system, and batting cages.
 - Concessions are the primary income other than registration.
 - Not sure if they can use the new fields at 1849 Park.
 - They are very thankful for what they have.

Appendix D - Public Engagement Notes

Parkhill

Page 2

QUESTIONS

STAKEHOLDER INPUT MTG: Pflugerville Athletic Field Feasibility Study

Date: 10/20/2025

STAKEHOLDER NAME: PAYS�

1. Stakeholder Contact Information?

- John Livingston, President.

2. What sport do you play?

- Soccer. Affiliated with USYS and US Club.

3. How many players do you have in your association?

- Annually rec. and select – 2200 players, some play 1 season and some play 2 seasons. 60/40 recreation/competitive. Indoor winter league – Let’s Play Soccer, Momentum Sports, and Manor H.S.

4. What age are your players?

- 3-19 yr olds. Largest demand is 8-12 yr old age group.

5. Do you know how many of your players are residents of Pflugerville?

- Players come from all over NE Austin area, 70% of players from Pflugerville.

6. Where do you play games in Pflugerville?

- Home games played in Pflugerville at Wells Point Park, Pfennig Park, 1849 Park, renting some fields from ISD, and away games in neutral site locations.

7. How many games per week?

- 100 per week, all on the weekend. 8:00am - 7:00pm on Sat. and 12:00pm - 6:00pm on Sun.

8. Where do you play games in the greater Austin area?

- N/A

9. Where do you practice in Pflugerville?

- Same as game fields, 70% of rec. league teams pay fee to use PAYS� fields for practice. Some indoor practice in the summer and winter – higher fee. Some teams find free space for practice, up to teams. Competitive league only practice at PAYS� fields.

10. Where do you practice in the greater Austin area?

- NA

11. Is your association growing?

- Growing each year, but resources of fields are constrained. Higher than pre-Covid and competition is increasing more than recreation.

12. Is there a certain demographic that is growing more or faster than others?

- Competition, boys more than girls. 8-10 yr boys and 6-8 yr old Academy.

13. What size of fields do you play on?

- Based on age and league affiliation.

14. Do you prefer natural grass or synthetic turf?

- Prefer grass but wouldn’t mind some synthetic to reduce weather delays. Downside of synthetic is the heat and multiple field striping requirements. They do not play on any synthetic fields in Pflugerville but have at some away games.

15. What is your greatest need currently?

- More fields. The ability to use all of 1849 Park for a special event, indoor fields, or covered outdoor fields.

16. Is there anything else you would like to share?

- Need storage at 1849 Park similar to Wells Point. Examples include bank of garages for different associations, fenced in lockable areas with roof.
- Need shaded spectator areas around the pods at 1849 Park.
- Concessions – vendor operated with grill and other cooked food, parent operated in the past, small revenue, no concessions at 1849 Park soccer fields.