

**Pfork in the Trail Sculpture**  
**By 220 Designs Inc**  
**Judd Graham**

**Conceptual Rendering**



**Artist Statement**

This sculpture takes the familiar form of a fork and transforms it into a meditation on how paths are made—through repetition, movement, and intention. At nine feet tall, it shifts from an everyday object into a landmark, a point of pause where direction and possibility meet. The fork is clad in hammered, forged bar, each strike a deliberate act. The textured surface reads as a record of movement and intentional force—an accumulation of marks that carry the rhythm of making. These bars, each with their own irregular pattern, are placed side by side in adjacent formations, creating a unified field across the surface. What might begin as randomness becomes composition, transforming the fork into a celebrated monument of pattern, labor, and place.

Each bar can be read as a trail—like tracks through the woods. The texture resembles footprints embedded in the material, impressions left behind by repeated passage. These are not only decorative gestures; they echo the way trails are formed: one step, then another, again and again, until a path emerges. What begins as an individual act becomes a shared route, shaped collectively over time through use and intention.

The emphasis here is not on a single moment of decision, but on the accumulation of actions that make direction possible. The fork, traditionally a symbol of choice, becomes instead a reflection of process. It suggests that paths are not simply discovered—they are created through movement, through participation, through the willingness to step forward.

The angel hair finish on the stainless steel softens reflection, allowing light to scatter across the textured surface rather than return a clear image. The sculpture shimmers instead of mirrors, activating the surface as viewers move around it. Light catches on the raised marks like footsteps catching light at different angles, reinforcing the sense of motion embedded in the material.

In this way, the work proposes that the future is not fixed, but built—step by step. Like trails through the woods, paths come into being through action. The fork stands at that threshold, not just marking a place of divergence, but honoring the collective imprint of those who move forward and, in doing so, create something new.

### **General Specifications**

The sculpture will have an internal 304 stainless steel square tube frame and a 304 stainless steel skin with ½” textured bars welded to the body. The tines will be welded to a ¾” stainless steel plate embedded in the concrete plinth.

### **Example of Textured Bars**



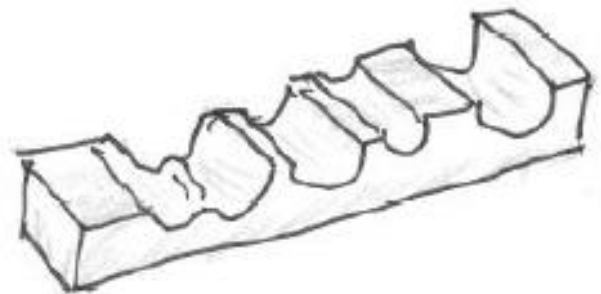

# Dimensional Measurements

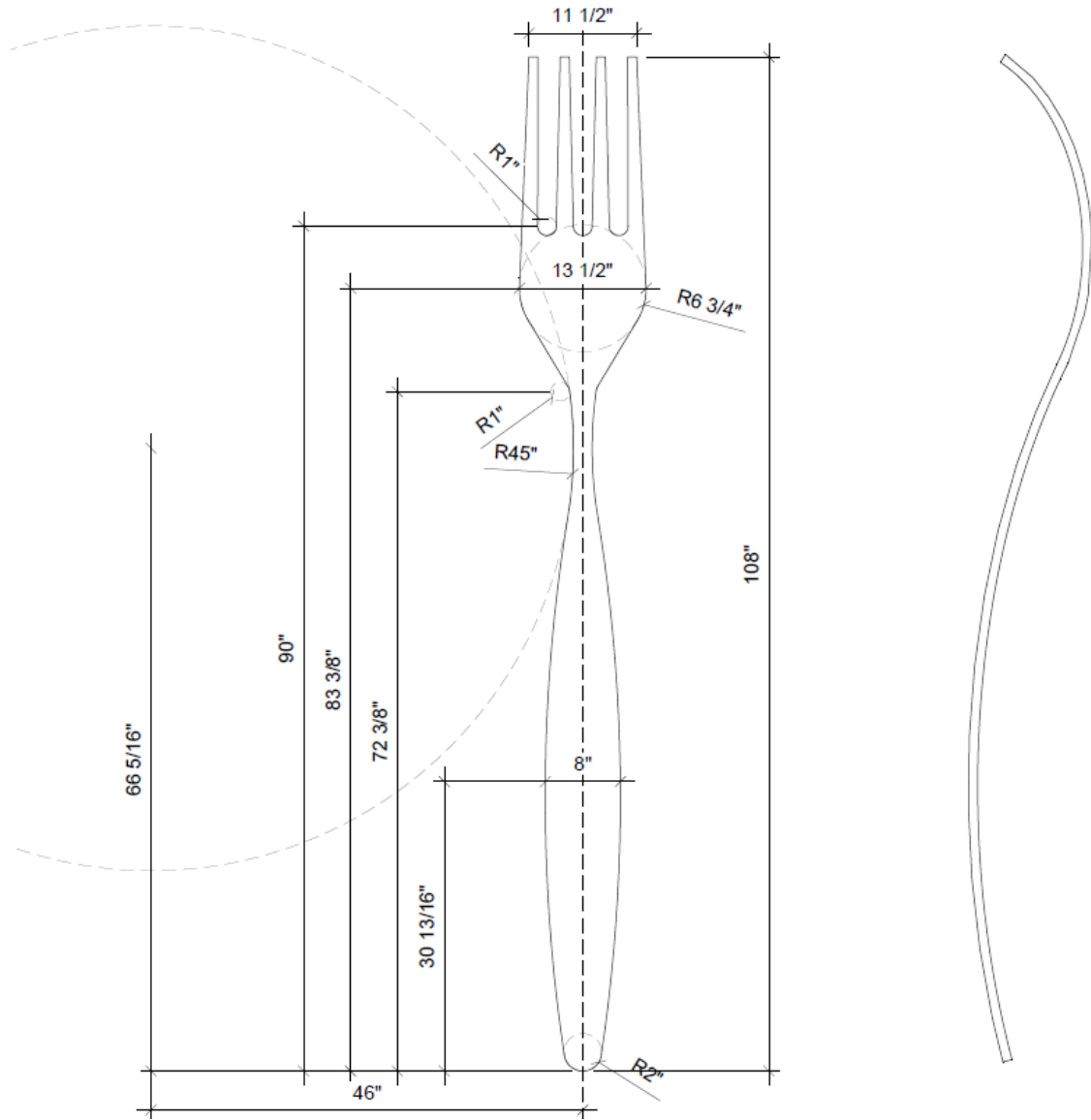

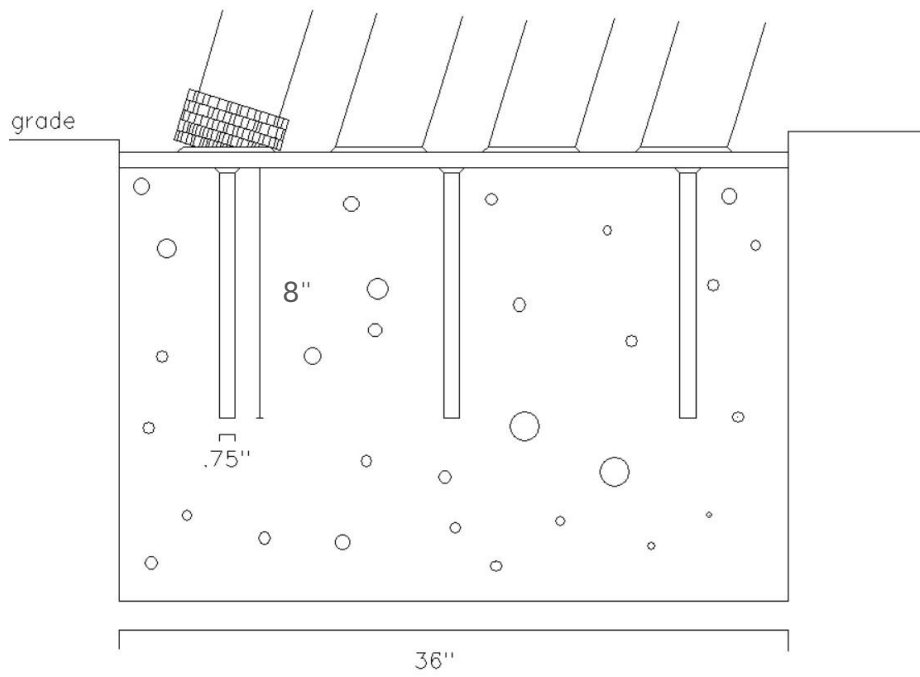
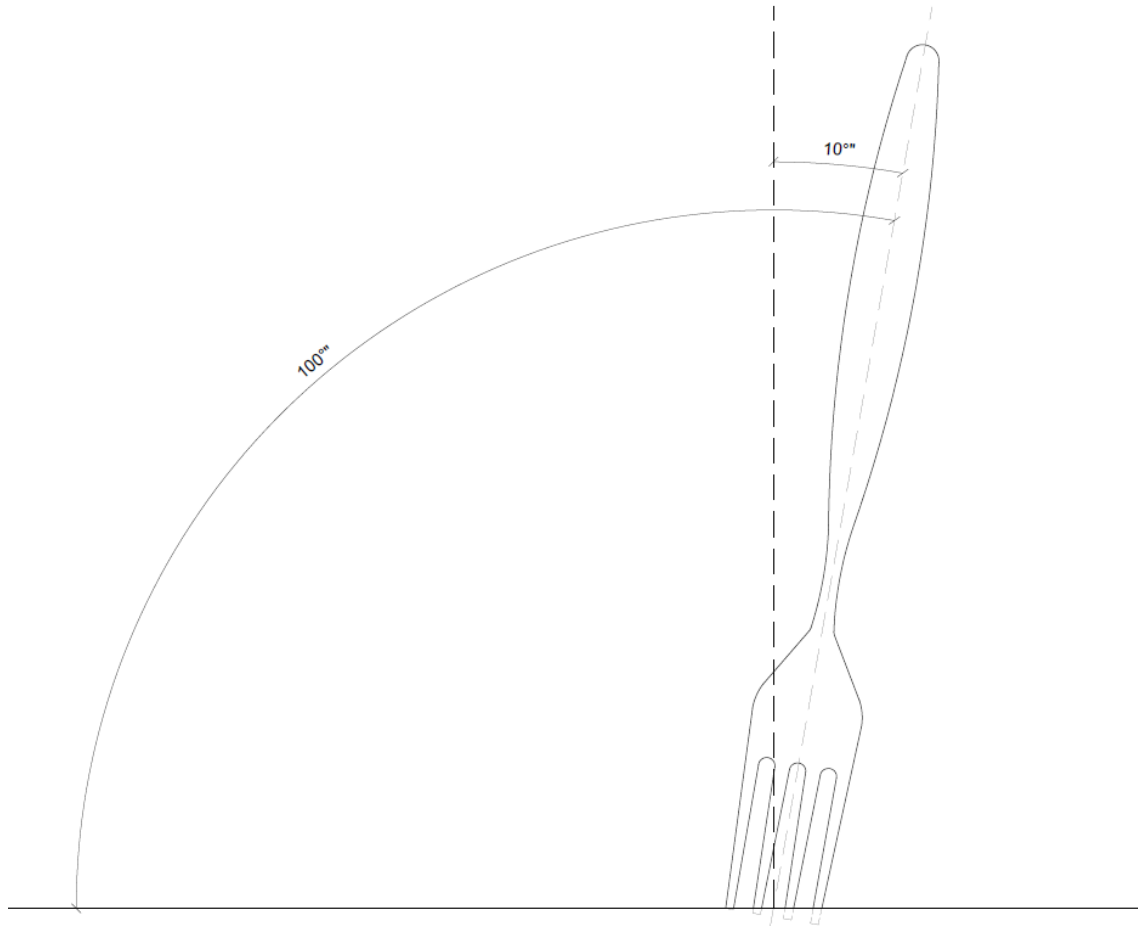

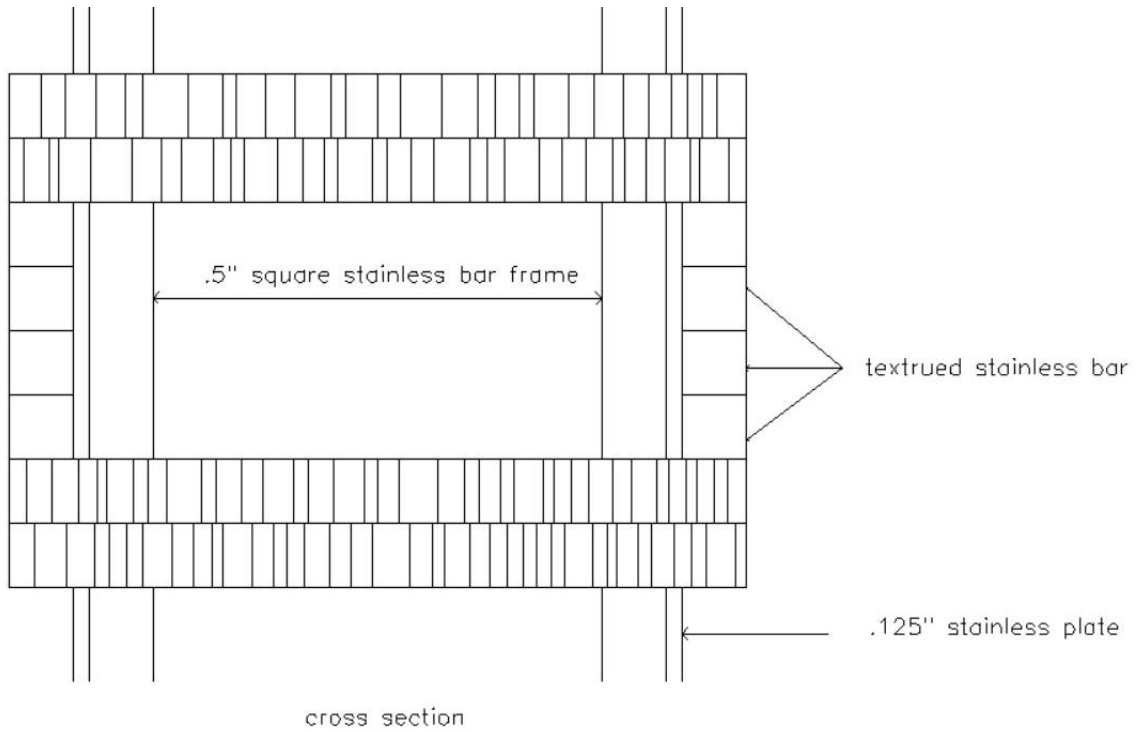

### Concrete Footer Specifications

