

PROJECT:

Pflugerville Historic EST Lighting Project
Pflugerville Historic EST Lighting Project

BIDDER:

SA Smart Solutions

TOTAL BID:

\$116,227.00

COMPLETION TIME:

Not Required

BIDDER INFO:

8610 N New Braunfels Ave
302
San Antonio, TX 78217
P: 2106289024
F:

BID TOTALS

BASE BID	Total
Base Bid	\$116,227.00
Total	\$116,227.00

ALTERNATE 1	Total
Alternative Bid 01	\$97,323.00
Total	\$97,323.00

ALTERNATE 2	Total
Alternative Bid 02	\$48,560.00
Total	\$48,560.00

ALTERNATE 3	Total
Alternative Bid 03	\$29,943.00
Total	\$29,943.00

ALTERNATE 4	Total
Alternative Bid 04	\$16,601.00
Total	\$16,601.00

Base Bid					
No.	Description	Unit	Qty	Unit Price	Ext Price
1	Total Base Bid	Dollar	1	\$116,227.00	\$116,227.00
					Subtotal: \$116,227.00

Alternative Bid 01					
No.	Description	Unit	Qty	Unit Price	Ext Price

1	Provide additional pricing to install ten (10) ColorBlast Powercore gen4 LED flood lights on balcony to illuminate City Logo in lieu of above specified lighting. Secure fixtures to balcony handrails. Lights are to be programmable and capable to change color as desired by the city.	Dollar	1	\$97,323.00	\$97,323.00
Subtotal: \$97,323.00					

Alternative Bid 02					
No.	Description	Unit	Qty	Unit Price	Ext Price
1	Provide additional pricing to install four (4) ColorBlast Powercore gen4 LED flood lights on each leg of the tower to illuminate the tower in the upward direction in lieu of above specified lighting. Secure fixtures to the tower legs. Lights are to be programmable and capable to change color as desired by the city.	Dollar	1	\$48,560.00	\$48,560.00
Subtotal: \$48,560.00					

Alternative Bid 03					
No.	Description	Unit	Qty	Unit Price	Ext Price

1	Provide additional pricing for labor and materials for temporary installation of approved alternate lighting system for mock-up test to determine quantity of balcony and leg lights. Mock-up test lights will be ColorBlast Powercore gen4 LED flood lights. Two (2) test lights, one (1) each on two adjacent legs of the tower to illuminate the tower in the upward direction. Two (2) test lights on the balcony of the tower to illuminate the logo of the tower in the upward direction. The two (2) balcony test lights shall be separated at a distance to replicate the spacing of ten (10) lights on the balcony. Secure fixtures to the tower legs. Lights are to be programmable and capable to change color as desired by the city.	Dollar	1	\$29,943.00	\$29,943.00
Subtotal: \$29,943.00					

Alternative Bid 04					
No.	Description	Unit	Qty	Unit Price	Ext Price
1	Provide additional pricing to install one (1) ColorBlast Powercore gen4 LED flood light on a leg or the balcony of the tower to illuminate the tower in the upward direction in lieu of above specified lighting. Secure fixtures to the tower legs. Lights are to be programmable and capable to change color as desired by the city.	Dollar	1	\$16,601.00	\$16,601.00
Subtotal: \$16,601.00					

ACKNOWLEDGE ADDENDA

NAME	ACKNOWLEDGEMENT DATE
Historic EST Lighting Project Addendum 01	06/18/2024 21:11:18 PM
Historic EST Lighting Project Addendum 02	06/18/2024 21:11:18 PM
Historic EST Lighting Project Addendum 03	06/18/2024 21:11:32 PM

REQUIRED DOWNLOADS

TYPE	NAME	DOWNLOAD DATE
Bid Docs	Historic EST Lighting Project Manual	5/22/2024 8:30:19 AM
Addenda	Historic EST Lighting Project Addendum 01	5/22/2024 8:30:58 AM
Addenda	Historic EST Lighting Project Addendum 02	6/7/2024 3:40:02 PM
Addenda	Historic EST Lighting Project Addendum 03	6/7/2024 3:40:05 PM



HISTORIC EST LIGHTING PROJECT

Prepared By



DUNHAM ENGINEERING, LLC
REGISTRATION NO. F-22537
6102 IMPERIAL LOOP DR.
COLLEGE STATION, TX 77845

5/8/2024

MAY 2024

HISTORIC EST LIGHTING PROJECT

TABLE OF CONTENTS

01 - BIDDING AND CONTRACT DOCUMENTS

01-1.0	Invitation for Bids
01-2.0	Instructions to Bidders
01-3.0	Proposal and Bid Schedule
01-4.0	Tax Code Compliance
01-5.0	Nonresident Bidders
01-6.0	Conflict of Interest Questionnaire
01-7.0	Non-Collusion Certification
01-8.0	Bid Bond
01-8.1	Insurance
01-9.0	Notice of Award
01-10.0	Notice to Proceed
01-11.0	City of Pflugerville Standard Capital Improvement Project (CIP) Construction Agreement between City and Contractor
01-12.0	Performance Bond
01-13.0	Payment Bond
01-14.0	Warranty Bond
01-15.0	General Conditions for City of Pflugerville CIP Construction Contracts
01-16.0	Special Conditions for City of Pflugerville CIP Construction Contracts
01-17.0	Prevailing Wage Rates

02 - STANDARD CAPITAL IMPROVEMENT PROJECT REQUIREMENTS AND SPECIFICATIONS

CIP1	Definition of Terms
CIP2	Abbreviations
CIP3	Summary of Work
CIP4	Site Conditions and Use
CIP5	Contractor Use of Premises
CIP6	Control of Work
CIP7	Control of Materials
CIP8	Legal Relations and Responsibilities to the Public
CIP9	Environmental Protection Procedures
CIP10	Submittals
CIP11	Trench Safety Requirements
CIP12	Testing of Pipelines and Manholes
CIP13	Summary of Testing (Miscellaneous)

- CIP14 Project Closeout
- CIP15 Project Identification Signage
- CIP16 Reserved
- CIP17 Inspection of Projects

03 - TECHNICAL SPECIFICATIONS

13 02 00 Historic EST Lighting Project

04 - APPENDICES

- A1 EST Lighting Renderings
- A2 EST Lighting Examples
- A3 Drawings, Map to Site, and Inspection Report

CITY OF PFLUGERVILLE INVITATION FOR BIDS

City of Pflugerville, Texas
County of Travis

Separate sealed bids addressed to the City of Pflugerville, will be received until 10 A.M. on June 19th, 2024 at the City of Pflugerville City Hall, 100 East Main, Suite 100, Pflugerville, Texas 78660 at which time they will be publicly opened and read aloud at Suite 500, for furnishing all labor; material, tools and equipment and performing all work required for the Historic EST Lighting Project which consists of approximately procurement and installation of external lighting fixtures as specified.

Bids must be submitted on the Proposal and Bid Schedule forms provided and must be accompanied by a bid security in a penal sum of not less than five percent (5%) of the total amount of the bid submittal. The security may be in the form of a certified check, cashier's check or bid bond furnished by a reliable surety company having authority under the laws of Texas to write surety bonds in the amount required, with such security made payable without recourse to the City. Bids will be submitted electronically at the following:

- www.civcastusa.com, Project ID – “Historic EST Lighting Project”

The final Notice of Award of Contract shall be issued to the successful bidder by the City within sixty (60) days following the opening of bids and no bidder may withdraw a bid within sixty (60) days after opening thereof. The successful Bidder must furnish a performance bond and payment bond on the forms provided, each in the amount of one hundred percent (100%) of the contract amount, from a surety company authorized by the State of Texas to act as surety.

State statutes, including Prevailing wage and hour provisions and contract regulations must be adhered to as they relate to this Project. Contractors will be required to comply with all applicable Equal Employment Opportunity laws and regulations.

Copies of the Specifications and Bid Documents may be examined at the following locations:

- www.civcastusa.com, Project ID – “Historic EST Lighting Project”

Bid Documents and Specifications may only be obtained electronically by the prospective bidders or suppliers at www.civcastusa.com at no charge. Project ID – “Historic EST Lighting Project”.

A **Non-Mandatory Pre-Bid Conference** will be held at 10 A.M. on June 5th, 2024, at the office of the City of Pflugerville Public Works Department, 15500 Sun Light Near Way #B, Pflugerville, Texas, 78660.

The City of Pflugerville reserves the rights to reject any and all bids and to waive any informalities in bids received; to eliminate a portion of the work or add additional work as required to keep the total contract amount within the funds budgeted; the right to award any parts or combination of parts of the project it deems necessary; and any other rights established under the laws of the State of Texas.

Honorable Victor Gonzales, Mayor
City of Pflugerville

CITY OF PFLUGERVILLE INSTRUCTIONS TO BIDDERS

1. PROPOSAL FORMS: All bidders shall use only the proposal form furnished, which will state the description of the proposed work, approximate quantities of the various items of work to be performed and materials to be furnished for which unit bid prices are asked. Terms not defined herein shall have the same meanings assigned thereto in the City's General Conditions.
2. ESTIMATES OF QUANTITIES: The quantities listed in the proposal form shall be considered as approximate and will be used for comparison of proposals. Payment to the contractor will be made only for the actual quantities of work performed or materials furnished in accordance with the contract, and it is understood that the quantities may be increased or decreased as provided in the General Conditions without invalidating the unit bid prices.
3. PLAN SPECIFICATIONS AND SITE OF WORK: Before submitting a proposal, the bidder shall examine the Project's Contract Documents carefully, including without limitation, the proposal, plans, specifications, special conditions of agreement, special provisions, and site of the proposed work. Bidder shall satisfy itself as to the character, quality and quantities of work to be performed and materials to be furnished. The submission of a proposal by a bidder shall be conclusive evidence that bidder has complied with these requirements. Claims for additional compensation due to variations between conditions actually encountered in construction and as indicated by the plans will not be allowed unless otherwise authorized by the Contract Documents.
4. PREPARATION OF PROPOSAL AND BID PACKAGE: Bidder must submit their proposal on the form furnished. The blank spaces for each item in the proposal form shall be correctly filled in, by writing in words and numerals, in ink. The bidder must submit a price for each item in the proposal. In case of conflict between words and numerals, the words shall govern unless otherwise addressed in the General Conditions. The proposal shall be executed with ink in the complete and correct name of the individual, firm or corporation making the proposal and signed by the person or persons authorized to bind the individual, firm or corporation. The bidder shall properly acknowledge all addenda in the spaces provided therefore on the proposal form.

The following forms shall be completed in their entirety and included with the bid package:

1. City of Pflugerville Proposal and Bid Schedule
2. City of Pflugerville State of Texas Tax Code, Chapter 151 Compliance Certificate
3. Compliance to Texas State Law Regarding Nonresident Bidders
4. Conflict of Interest Questionnaire
5. City of Pflugerville Non-Collusion Certificate
6. City of Pflugerville Bid Bond

Persons desiring further information or interpretation of the Plans or Specifications must make a written request via www.civcastusa.com under Project ID "Historic EST Lighting Project" for such information to the Design Consultant at least **seventy-two (72) hours** prior to the time set for the opening of proposals. The person submitting the request will be

responsible for its prompt delivery. Any interpretation of the Plans, Specifications and Contract Documents will be made by addendum only and a copy of each addendum will be posted on www.civcastusa.com.

5. REJECTION OF PROPOSALS: Proposals containing any omission, alteration of form, additions or conditions not called for, incomplete bids, or proposals otherwise regular, but that are not accompanied by acceptable bid security will be considered irregular and may be rejected. In any case of ambiguity or lack of clearness in stating the prices in the proposal, the Owner reserves the right to consider the most advantageous construction thereof, or to reject the proposal. Unreasonable or unbalanced unit bid prices will be cause to reject any proposal.
6. BID SECURITY: Each proposal must be accompanied by a cashier's or certified check, payable to the City of Pflugerville or an acceptable bid bond in the amount of not less than five percent (5%) of the total amount bid, as a guarantee that bidder will enter into a contract and furnish bonds, if required, on the forms provided within ten (10) days after Notice of Award of the contract..
7. DELIVERY OF PROPOSAL: Each completed proposal shall be placed, together with the bid security, in a sealed envelope clearly identified on the outside as a proposal for Historic EST Lighting Project. When sent by mail, the sealed proposal, marked as indicated above, should be enclosed in an additional envelope. Acknowledgement of all issued Addenda shall be made on the Bid Form. Proposals will not be considered unless submitted on or before the time designated in the Notice to Bidders. Late proposals shall be returned unopened.
8. WITHDRAWAL OF PROPOSALS: Any bidder, upon written request, will be permitted to withdraw the bidder's proposal not later than the time set for the opening thereof. No bidder may withdraw a proposal within sixty (60) days after the date of the opening of bids.
9. DISQUALIFICATION OF BIDDERS: The following causes may be considered as sufficient for the disqualification of a bidder and the rejection of the bidder's proposal:
 - a. Submittal of more than one proposal for the same work from an individual, firm, partnership or corporation, or affiliate or subsidiary thereof.
 - b. Evidence of collusion among bidders or evidence of impermissible ex parte communications initiated by the bidder to City officials or employees not in accordance with the terms of the City's proposal processes.
 - c. Poor performance in the execution of work under previous contracts.
 - d. For being in arrears on existing contracts, in litigation with Owner, or having defaulted on a previous contract.
 - e. A bidder, proposer, or other person interested in receiving the award of a contract from the city or entering into any other transaction with the city shall be deemed non-responsible and shall be denied any contract or other

transaction with the city if that bidder, proposer, or other person is indebted to the city or is delinquent in any payment owed to the city under a contract or other legal obligation, or otherwise is not eligible to contract with the city under Chapter 38 of the City's adopted Code of Ordinances.

10. CONSIDERATION OF PROPOSALS: For the purpose of award, after the proposals are opened and read, the summation of the products of the approximate quantities shown in the proposal by the unit bid prices will be considered the amount of the bid. The summations will then be compared, and the results made available to the bidders. The City reserves the right to reject any and all bids and to waive any and all informalities and irregularities in bids received.
11. AWARD OF CONTRACT: The award of the contract, if awarded, will be to the lowest responsive and responsible bidder meeting the requirements of the Owner, or to the bidder that provides goods or services at the best value for the municipality, in accordance with Texas Local Government Code, Chapter 252, as amended. The City reserves the right to consider and award a contract in conformance with any preference established by State law, including without limitation, those established by Texas Local Government Code, Chapter 271, Subchapter Z.
12. EXECUTION OF CONTRACT AND BONDS: The contract will include the Invitation for Bids, Instructions to Bidders, bidder's Proposal, any Addenda issued, and all other Contract Documents specified within the City of Pflugerville Standard Capital Improvement Project (CIP) Construction Agreement between City and Contractor. Within ten (10) days after issuance of a Notice of Award of the contract, the successful bidder shall execute the contract and furnish City of Pflugerville with a Performance Bond and labor and materials payment bond, each in the full amount of the contract price. The bonds are to be furnished as a guarantee of the faithful performance of the work for the protection of the Owner against defective workmanship or materials, and as a guarantee that bidder shall pay all sums for labor and materials incorporated therein.
13. APPROVAL OF CONTRACT: Upon receipt of the Contractor's executed contract and required security bonds, the contract will be executed by the Owner and delivered to the Contractor. The contract will not be binding upon the Owner until it has been executed by the Owner and delivered to the contractor.
14. FAILURE TO EXECUTE CONTRACT AND BONDS: Should the bidder to whom the contract is awarded refuse or neglect to execute the contract and furnish the required bonds within ten (10) days after issuance of the Notice of Award of the contract, the bid security shall become the property of the Owner, not as a penalty but as liquidated damages.
15. PURSUING THE WORK: The contractor shall commence work on or before, if agreed to by the City, a date to be specified in a written Notice to Proceed issued by the Owner and shall substantially complete the work within the number of days set forth in the Proposal, in accordance with the Contract Documents.

End of Instructions to Bidders.

CITY OF PFLUGERVILLE PROPOSAL AND BID SCHEDULE

Proposal of SA Smart Solutions, LLC (hereinafter called "Bidder"), doing business as a **corporation** / a partnership / an individual (strike out inapplicable terms), to the CITY OF PFLUGERVILLE (hereinafter called "Owner").

City of Pflugerville:

The Bidder, in compliance with your invitation for bids for the construction of Historic EST Lighting Project, having examined the Plans and Specifications and related documents, the site of the proposed Work, and being familiar with all of the conditions surrounding the construction of the proposed project, including materials and supplies, and to construct the project in accordance with the Plans, Specifications and Contract Documents, within the time set forth therein, and in performing the Work required under the Contract Documents, of which this proposal is part.

Bidder hereby agrees to commence work under this Contract on or before a date to be specified in written "Notice to Proceed" issued by the Owner and to Substantially and Finally Complete the Work within 60 and 75 consecutive calendar days thereafter. Bidder further agrees to pay as liquidated damages the sum set forth in the City of Pflugerville Standard Capital Improvement Project (CIP) Construction Agreement between City and Contractor for each consecutive calendar day thereafter.

Bidder acknowledges receipt of the following ADDENDA:

Addendum No. 1 dated <u>5/20/2024</u>	Received <u>✓</u>
Addendum No. 2 dated <u>5/23/2024</u>	Received <u>✓</u>

BASE BID ITEMS

Item No.	Estimated Quantity	Description and Price in Words	Total Price
1.	Lump Sum	Furnish material and labor to install an exterior lighting system for the 50,000-gallon elevated storage tank, per the Technical Specifications: One hundred sixteen thousand two hundred twenty seven \$ _____ dollars and ⁰⁰ _____ cents	\$116,227.00 _____

BASE BID ITEMS

Base Bid - Total of Items 1 above: \$ _____ One hundred sixteen thousand two hundred twenty seven dollars and ⁰⁰ _____ cents

Alternate Bid Item #1 Lump Sum

Provide approved alternate lighting system in lieu of the specified lighting system to install ten (10) ColorBlast Powercore gen4 LED flood lights on balcony to illuminate City Logo in lieu of above specified lighting. Secure fixtures to balcony handrails. Lights are to be programmable and capable to change color as desired by the city.

An additional \$ 97,323.00 _____
Or deduction of \$ _____
From the base bid.

Alternate Bid Item #2 Lump Sum

Provide approved alternate lighting system in lieu of the specified lighting system to install four (4) ColorBlast Powercore gen4 LED flood lights on each leg of the tower to illuminate the tower in the upward direction in lieu of above specified lighting. Secure fixtures to the tower legs. Lights are to be programmable and capable to change color as desired by the city.

An additional \$ 48,560.00 _____
Or deduction of \$ _____
From the base bid.

Alternate Bid Item #3 Lump Sum

Provide labor and materials for temporary installation of approved alternate lighting system for mock-up test to determine quantity of balcony and leg lights. Mock-up test lights will be ColorBlast Powercore gen4 LED flood lights. Two (2) test lights, one (1) each on two adjacent legs of the tower to illuminate the tower in the upward direction. Two (2) test lights on the balcony of the tower to illuminate the logo of the tower in the upward direction. The two (2) balcony test lights shall be separated at a distance to replicate the spacing of ten (10) lights on the balcony. Secure fixtures to the tower legs. Lights are to be programmable and capable to change color as desired by the city.

An additional \$ 29,943.00 _____
Or deduction of \$ _____
From the base bid.

(Attach additional sheet if necessary)

Respectfully submitted:

Bidder: SA Smart Solutions, LLC
(typed or printed name of organization)

Signature: 
(individual's signature)

Name: Andrew Berteaux
(typed or printed)

Title: Managing Partner
(typed or printed)

Date: 6/18/2024
(typed or printed)

Business Address: 8610 N New Braunfels Ave Suite 302

San Antonio, TX, 78217

Email: andrew@satxsmart.com

Phone: 210.628.9024

(Attach evidence of authority to sign if Bidder is a corporation, partnership, or a joint venture.)

(Seal – if bid by a corporation)

**CITY OF PFLUGERVILLE STATE OF TEXAS TAX CODE,
CHAPTER 151 COMPLIANCE CERTIFICATE**

Contractor shall comply with all applicable sales, excise, and use tax requirements of the Texas Tax Code. The Contractor hereby certifies that the Contract Sum is divided as follows:

Tax exempt products, materials, and services (See Notes 1 and 2)	\$ _____
Taxable products, materials, and services (See Note 3)	\$ _____
Total (See Note 4)	\$ _____

Contractor: SA Smart Solutions, LLC

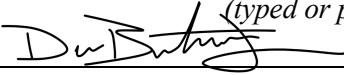
Signature: 
(typed or printed name of organization)
(individual's signature)

Name: Andrew Berteaux
(typed or printed)

Title: Managing Partner
(typed or printed)

Business Address:
8610 N New Braunfels Ave Suite 302
San Antonio, TX, 78217

Phone: 210.628.9024 Email: andrew@satxsmart.com

Note:

1. Exempt products and materials are those items purchased for the Project which are physically incorporated into the Project constructed for the City or are necessary and essential for providing the Work and are completely consumed for the Project. For purposes of this definition, products and materials are completely consumed if after being used once for its intended purpose it is used up or destroyed. Products and materials rented or leased for use in providing the Work cannot be completely consumed for the purposes of this definition.
2. Exempt services are those services performed at the Project Site where the Contract expressly requires the specific service to be provided or purchased by the person performing the service and is integral to completing the Work.
3. Products, materials, and services are not tax exempt if they are used by the Contractor but are not physically incorporated into the City's Project or are not consumed by construction or installation as defined above. Machinery or equipment and its accessories and repair and replacement parts used in providing the Work are not exempt.
4. The total sum of the amount for tax exempt and taxable products, materials, and services must equal the Contract Sum.

END OF SECTION

CITY OF PFLUGERVILLE COMPLIANCE TO TEXAS STATE

LAW REGARDING NONRESIDENT BIDDERS

Texas Government Code Chapter 2252 applies to the award of government contract to nonresident bidders. This chapter provides that:

“a government entity may not award a governmental contract to a nonresident bidder unless the nonresident underbids the lower bid submitted by a responsible resident bidder by an amount that is not less than the amount by which a resident bidder would be required to underbid the nonresident bidder to obtain a comparable contract in the state in which the nonresident’s principal place of business is located.”

“Nonresident bidder” refers to a person who is not a resident of Texas.

“Resident bidder” refers to a person whose principal place of business is in this state, including a contractor whose ultimate parent company or majority owner has its principal place of business in this state.

Check the statement that is correct for Bidder:

- Bidder (includes parent company or majority owner) qualifies as a resident bidder whose principal place of business is in the state of Texas.

- Bidder qualifies as a nonresident bidder whose principal place of business or residency is in the state of: _____

Any determination of state bidder preference law is based on the Texas Comptroller’s annual summary of other state bidder preference laws.

Bidder: SA Smart Solutions, LLC
(typed or printed name of organization)

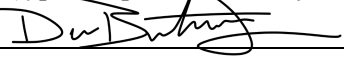
Signature: 
(individual’s signature)

Name: Andrew Berteaux
(typed or printed)

Title: Managing Partner
(typed or printed)

Business Address: 8610 N New Braunfels Ave Suite 302

San Antonio, TX, 78217

Phone: 210.628.9024 Email: andrew@satxsmart.com

(Attach evidence of authority to sign if Offeror is a corporation, partnership, or a joint venture.)

END OF SECTION

CONFLICT OF INTEREST QUESTIONNAIRE**FORM CIQ****For vendor doing business with local governmental entity**

This questionnaire reflects changes made to the law by H.B. 23, 84th Leg., Regular Session.

This questionnaire is being filed in accordance with Chapter 176 of the Local Government Code by a vendor who has a business relationship as defined by Section 176.001(1-a) with a local governmental entity and the vendor meets requirements under Section 176.006(a).

By law this questionnaire must be filed with the records administrator of the local governmental entity not later than the 7th business day after the date the vendor becomes aware of facts that require the statement to be filed. See Section 176.006(a-1), Local Government Code.

A vendor commits an offense if the vendor knowingly violates Section 176.006, Local Government Code. An offense under this section is a misdemeanor.

OFFICE USE ONLY

Date Received

1 Name of vendor who has a business relationship with local governmental entity.

SA Smart Solutions, LLC

2 Check this box if you are filing an update to a previously filed questionnaire. (The law requires that you file an updated completed questionnaire with the appropriate filing authority not later than the 7th business day after the date on which you became aware that the originally filed questionnaire was incomplete or inaccurate.)

3 Name of local government officer about whom the information is being disclosed.

N/A

Name of Officer

4 Describe each employment or other business relationship with the local government officer, or a family member of the officer, as described by Section 176.003(a)(2)(A). Also describe any family relationship with the local government officer. Complete subparts A and B for each employment or business relationship described. Attach additional pages to this Form CIQ as necessary.

A. Is the local government officer or a family member of the officer receiving or likely to receive taxable income, other than investment income, from the vendor?

Yes No

B. Is the vendor receiving or likely to receive taxable income, other than investment income, from or at the direction of the local government officer or a family member of the officer AND the taxable income is not received from the local governmental entity?

Yes No

5 Describe each employment or business relationship that the vendor named in Section 1 maintains with a corporation or other business entity with respect to which the local government officer serves as an officer or director, or holds an ownership interest of one percent or more.

6 Check this box if the vendor has given the local government officer or a family member of the officer one or more gifts as described in Section 176.003(a)(2)(B), excluding gifts described in Section 176.003(a-1)

7 
Signature of vendor doing business with the governmental entity

6/18/2024

Date

CONFLICT OF INTEREST QUESTIONNAIRE
For vendor doing business with local governmental entity

A complete copy of Chapter 176 of the Local Government Code may be found at <http://www.statutes.legis.state.tx.us/Docs/LG/htm/LG.176.htm>. For easy reference, below are some of the sections cited on this form.

Local Government Code § 176.001(1-a): "Business relationship" means a connection between two or more parties based on commercial activity of one of the parties. The term does not include a connection based on:

- (A) a transaction that is subject to rate or fee regulation by a federal, state, or local governmental entity or an agency of a federal, state, or local governmental entity;
- (B) a transaction conducted at a price and subject to terms available to the public; or
- (C) a purchase or lease of goods or services from a person that is chartered by a state or federal agency and that is subject to regular examination by, and reporting to, that agency.

Local Government Code § 176.003(a)(2)(A) and (B):

(a) A local government officer shall file a conflicts disclosure statement with respect to a vendor if:

(2) the vendor:

(A) has an employment or other business relationship with the local government officer or a family member of the officer that results in the officer or family member receiving taxable income, other than investment income, that exceeds \$2,500 during the 12-month period preceding the date that the officer becomes aware that

- (i) a contract between the local governmental entity and vendor has been executed;
- or
- (ii) the local governmental entity is considering entering into a contract with the vendor;

(B) has given to the local government officer or a family member of the officer one or more gifts that have an aggregate value of more than \$100 in the 12-month period preceding the date the officer becomes aware that:

- (i) a contract between the local governmental entity and vendor has been executed; or
- (ii) the local governmental entity is considering entering into a contract with the vendor.

Local Government Code § 176.006(a) and (a-1)

(a) A vendor shall file a completed conflict of interest questionnaire if the vendor has a business relationship with a local governmental entity and:

- (1) has an employment or other business relationship with a local government officer of that local governmental entity, or a family member of the officer, described by Section 176.003(a)(2)(A);
- (2) has given a local government officer of that local governmental entity, or a family member of the officer, one or more gifts with the aggregate value specified by Section 176.003(a)(2)(B), excluding any gift described by Section 176.003(a-1); or
- (3) has a family relationship with a local government officer of that local governmental entity.

(a-1) The completed conflict of interest questionnaire must be filed with the appropriate records administrator not later than the seventh business day after the later of:

(1) the date that the vendor:

- (A) begins discussions or negotiations to enter into a contract with the local governmental entity; or
- (B) submits to the local governmental entity an application, response to a request for proposals or bids, correspondence, or another writing related to a potential contract with the local governmental entity; or

(2) the date the vendor becomes aware:

- (A) of an employment or other business relationship with a local government officer, or a family member of the officer, described by Subsection (a);
- (B) that the vendor has given one or more gifts described by Subsection (a); or
- (C) of a family relationship with a local government officer.

CITY OF PFLUGERVILLE NON-COLLUSION CERTIFICATION

STATE OF Texas
COUNTY
OF Travis

Contractor: **[Buyer]**
[Street address]
[City, state, zip code]

Contract: **Historic EST Lighting Project**
[Project number]

Contractor certifies that it has not been a party to any collusion among Contractors in the restraint of freedom of competition by agreement to submit a Bid or Proposal at a fixed price or to refrain from submitting a Bid or Proposal; or with any official or employee of the City as to quantity, quality, or price in the prospective contract, or any other terms of said prospective contract; or in any discussion between Contractors and any official of the City concerning exchange of money or other thing of value for special consideration in the letting of a contract.

Contractor: SA Smart Solutions, LLC
(typed or printed name of organization)

Signature: 
(individual's signature)

Name: Andrew Berteaux
(typed or printed)

Title: Managing Partner
(typed or printed)

Business Address:
8610 N New Braunfels Ave Suite 302
San Antonio, TX, 78217

Phone: 210.628.9024 Email: andrew@satxsmart.com
(Attach evidence of authority to sign if Contractor is a corporation, partnership, or a joint venture.)

END OF SECTION

CITY OF PFLUGERVILLE BID BOND

STATE OF TEXAS §
COUNTY OF TRAVIS §
CITY OF PFLUGERVILLE §

KNOW ALL MEN BY THESE PRESENTS, that we, the undersigned, _____
_____ as Principal, and _____
_____ as Surety, are hereby held and
firmly bound unto the City of Pflugerville, Texas as OWNER in the penal sum of
_____ Dollars (\$ _____) (5% of Bid Amount) for the
payment of which, well and truly to be made, we hereby jointly and severally bind ourselves, our
heirs, executors, administrators, successors and assigns.

The Condition of the above obligation is such that whereas the Principal has submitted to OWNER
a certain BID, to enter into a contract in writing for the Historic EST Lighting Project (the
“Project”), which is attached hereto and incorporated herein for all purposes.

NOW, THEREFORE, Principal and Surety agree as follows:

- (a) If said BID shall be rejected; or,
- (b) If said BID shall be accepted and the Principal shall execute and deliver a contract
in the form of Contract attached hereto and incorporated herein for all purposes (properly
completed in accordance with the Contract Documents) and shall furnish a performance
bond ensuring faithful performance of said Contract, and a payment bond ensuring the
payment of all persons performing labor or furnishing materials in connection therewith,
and shall in all other respects enter into the Contract under the terms of said BID proposal,
then this obligation shall be void; otherwise the same shall remain in force and effect; it being
expressly understood and agreed that the liability of the Surety for any and all claims hereunder
shall, in no event, exceed the penal amount of this obligation as herein stated.

The Surety, for value received, hereby stipulates and agrees that the obligations of said
Surety and its BOND shall be in no way impaired or affected by any extension of the time within
which the OWNER may accept such BID and said Surety does hereby waive notice of any such
extension.

The obligations of the parties under this BOND shall be performable in Travis County, Texas and shall be construed under the laws of the State of Texas. If legal action is necessary in connection with this BOND, exclusive venue shall be in Travis County, Texas.

Surety companies executing this BOND must appear on the United States Treasury Department's most current list (Circular 570, as amended) and otherwise be authorized to transact business in the State of Texas.

IN WITNESS WHEREOF, the Principal and the Surety have hereunto set their hands and seals and such of them as are corporations have caused their corporate seals to be hereto affixed and these presents to be signed by their proper officers, the day and year first set forth above.

Signed and Agreed to this _____ day of _____, 20_____.

SURETY (seal)

PRINCIPAL/CONTRACTOR

By: _____
(Signature)

By: _____
(Signature)

(Print Name)

(Print Name)

(Print Title)

(Print Title)

[ATTACH POWER OF ATTORNEY]

[Additional signatures, if any,
attached]

ATTEST: _____

ATTEST: _____

CITY OF PFLUGERVILLE CERTIFICATE OF INSURANCE

Contractor shall establish and provide certificates of insurance to the City satisfying the requirements for coverages established by **Article XI** of the General Conditions for City of Pflugerville CIP Construction Contracts. Delivery of said proof of insurance coverages shall be no later than the date of the Pre-Construction meeting and prior to the commencement of any Work under the Contract, in accordance with **Section 1.2.3** of the General Conditions.

END OF SECTION

CITY OF PFLUGERVILLE NOTICE OF AWARD

To: _____ Project Description: Historic EST Lighting

_____ Project.

The OWNER has considered the BID submitted by you for the described WORK in response to its Invitation to Bid dated _____.

You are hereby notified that your BID has been accepted for items in the amount of \$ _____ (Written Amount).

You are required by the Instructions to Bidders to execute the Agreement and furnish the required CONTRACTOR'S Performance Bond, Payment Bond and Certificates of Insurance within ten (10) calendar days from the date of this notice to you.

If you fail to execute said Agreement and to furnish said bonds within ten (10) calendar days from the date of this Notice, said OWNER will be entitled to consider all OWNER'S rights arising out of the OWNER'S acceptance of your BID BOND. The OWNER will be entitled to such other rights as may be granted by law.

Note, that you are also required to complete and submit a Certificate of Interested Parties (Form 1295) to the OWNER as required by Texas Government Code Chapter 2252 and the Contract with the formal Contract Agreement.

Finally, you are required to return, as acknowledged, a copy of the NOTICE OF AWARD to the OWNER.

Dated this _____ day of _____, 20__.

Owner: City of Pflugerville

Signature: _____
(individual's signature)

Name: _____
(typed or printed)

Title: _____
(typed or printed)

ACCEPTANCE OF NOTICE

Receipt of the above NOTICE OF AWARD is hereby acknowledged

Contractor: _____
(typed or printed name of organization)

Signature: _____
(individual's signature)

Name: _____
(typed or printed)

Title: _____
(typed or printed)

Date: _____
(typed or printed)

CITY OF PFLUGERVILLE NOTICE TO PROCEED

To: SA Smart Solutions, LLC Date: _____

Project: Historic EST Lighting Project

You are hereby notified, in accordance with **Section 1.2.4** of the General Conditions to commence Work in accordance with the Contract dated _____ 20_____, on or before _____, 20_____, and you are to substantially and Finally Complete the Work within 60 and 75 consecutive calendar days thereafter.

The dates of Substantial and Final Completion of all WORK is therefore _____, 20__ and _____, 20__, respectively, unless otherwise extended in accordance with the Contract.

Owner: City of Pflugerville
Signature: _____
(individual's signature)
Name: _____
(typed or printed)
Title: _____
(typed or printed)

ACCEPTANCE OF NOTICE

Receipt of the above NOTICE TO PROCEED is hereby acknowledged and accepted

Contractor: _____
(typed or printed name of organization)
Signature: _____
(individual's signature)
Name: _____
(typed or printed)
Title: _____
(typed or printed)
Date: _____
(typed or printed)

**CITY OF PFLUGERVILLE STANDARD CAPITAL IMPROVEMENT PROJECT (CIP)
CONSTRUCTION AGREEMENT BETWEEN CITY AND CONTRACTOR**

THIS AGREEMENT is entered into by and between City of Pflugerville, Texas (CITY) and SA Smart Solutions, LLC (CONTRACTOR). CITY and CONTRACTOR, in consideration of the mutual covenants, obligations and responsibilities herein established, agree as follows:

SECTION I. Generally.

Terms. Terms used in this Agreement, unless the context clearly indicates otherwise, will have the meanings indicated in the General Conditions attached hereto.

Work. CONTRACTOR shall complete all Work as defined in the General Conditions, and as specified or indicated in the other Contract Documents. The Work is generally referred to as Historic EST Lighting Project regardless of whether the Work may only be a part of the Project, with the Work being generally described as follows:

Major items of the Work include:

- * Procurement and installation of external lighting fixtures as specified

The Project. The Project, for which the Work under the Contract Documents may be the whole or only a part of, is generally described under Article I above.

Design Consultant. The Design Consultant for the Project is:

Dunham Engineering, LLC.
Steven C. Johns, Project Manager
6102 Imperial Loop Dr
College Station, TX 77845
979-690-6555

who is referred to as such in the Contract Documents for the purposes stated therein. The CITY shall provide written notice to the CONTRACTOR if any information regarding this designation should change during the course of this Agreement.

SECTION II. Contract Times/Liquidated Damages.

Time of the Essence. All time limits for Milestones, if any, Substantial Completion, and Final Completion and readiness for final payment as stated in the Contract Documents are of the essence of the Contract.

Milestones, Substantial Completion and Final Completion. The Work will be Substantially Completed within 60 days after the date when the Contract Times commence to run as provided in **Section 1.2.4** of the General Conditions, and Finally Completed and ready for final payment in accordance with **Section 13.1** of the General Conditions within 75 days after the date when the Contract Times commence to run.

Liquidated Damages. CONTRACTOR and CITY recognize that time is of the essence of this Agreement and that CITY will suffer financial loss if the Work is not completed within the times specified in **Section II** herein above, plus any extensions thereof allowed in accordance with the General Conditions. The parties also recognize the delays, expense, and difficulties involved in proving in a legal or arbitration proceeding the actual loss suffered by CITY if the Work is not completed on time. Accordingly, instead of requiring any such proof, CITY and CONTRACTOR agree that as liquidated damages for delay, but expressly acknowledged
DNRBZ 2018 1210

herein as not being a penalty, **CONTRACTOR shall pay CITY \$500 for each day that expires after the time specified in Section II herein for Substantial Completion until the Work is Substantially Complete.** After Substantial Completion, if CONTRACTOR shall neglect, refuse, or fail to complete the remaining Work within the Contract Time or any proper extension thereof granted by CITY for Final Completion, **CONTRACTOR shall pay CITY \$500 for each day that expires after the time specified in Section II herein for Final Completion and readiness for final payment until the Work is completed and ready for final payment.**

SECTION III. Contract Sum.

CITY shall pay CONTRACTOR for completion of the Work in accordance with the Contract Documents an amount equal to the sum of the following, as applicable:

- (1) For all Work other than Unit Price Work, a Lump Sum of:

_____ (\$_____).

The Lump Sum above includes all allowances computed in accordance with **Section 3.8** of the General Conditions.

- (2) For all Unit Price Work, an amount equal to the sum of the established unit price for each separately identified item of Unit Price Work times the estimated quantity of that item as follows:

See CONTRACTOR'S SUBMITTED BID PROPOSAL, which is incorporated herein by reference for all purposes.

Sum of all Unit Prices: _____ \$_____ (dollars).

CONTRACTOR acknowledges that estimated quantities are not guaranteed and that the determination of actual quantities will be made in accordance with **Sections 9.3-9.6** of the General Conditions.

SECTION IV. Payments.

Submittal and Processing of Payments. CONTRACTOR shall submit Applications for Payment in accordance with **Article IX** of the General Conditions. CITY shall make progress payments on account of the Contract Sum on the basis of CONTRACTOR's Applications for Payment in accordance with **Article IX** of the General Conditions. Prior to Final Completion, progress payments will be made in an amount equal to authorized amount, less the applicable retainage percentage indicated within **Section 9.6** of the General Conditions, less permissible amounts withheld, in accordance with **Article IX** of the General Conditions.

SECTION V. Representations.

Representations. In order to induce CITY to enter into this Agreement CONTRACTOR makes the following representations in addition to those otherwise provided in the Contract Documents:

- (1) CONTRACTOR has comprehensively evaluated the Contract Documents and the other information identified in the Bidding Documents and has visited the Project Site and is satisfied as to the Site conditions that may affect completion of the Work.

- (2) CONTRACTOR has further carefully evaluated all: (a) information regarding subsurface conditions at or contiguous to the Site and all drawings relating to existing surface or subsurface structures at or

contiguous to the Site that have been identified in the Contract Documents, if any; and (b) information regarding a Hazardous Environmental Condition, if any, at the Site as identified in Contract Documents.

(3) CONTRACTOR has obtained and carefully evaluated all additional or supplementary information concerning surface and subsurface conditions at or contiguous to the Site that may affect CONTRACTOR'S completion of the Work for the stated Contract Sum within the stated Contract Time. Accordingly, based on said evaluations, CONTRACTOR hereby acknowledges and confirms that no additional information is necessary for the performance of the Work at the Contract Sum, within the Contract Times, and in accordance with the conditions of the Contract Documents.

(4) Finally, CONTRACTOR has provided written notice of all discrepancies that CONTRACTOR has discovered in the Contract Documents to the City or Design Consultant, and hereby acknowledges that all such discrepancies have been resolved sufficiently by the Design Consultant

SECTION VI. Additional Terms.

Controlling Law/Venue. This Agreement shall be governed by the laws of the State of Texas without regard to its conflicts of laws. Venue for any dispute resolution or legal proceedings lies exclusively in the Courts of Travis County, Texas.

Waiver. The failure of either Party hereto to enforce any provision of this Agreement does not constitute a waiver of that provision, affect the enforceability of that provision, or the enforceability of the remainder of this Agreement.

Third Party Beneficiaries. Nothing in this Agreement is intended to be by the Parties hereto or shall be construed to create rights in any person or entity other than the Parties hereto.

Execution. This Agreement may be executed in one or more counterparts and may be exchanged by facsimile or other electronic means. It is stipulated and agreed that any counterpart containing a signature or facsimile signature of the authorized representatives of the respective Party will be deemed an original for all purposes.

Authorization. CONTRACTOR represents that CONTRACTOR has the power and authority to execute and enter into this Agreement. The execution and delivery of this Agreement and the performance of the Work hereunder has been duly authorized by all necessary corporate action, if applicable. Upon execution, this Agreement will constitute the binding and valid obligations of CONTRACTOR and shall be enforceable in accordance with its terms. CONTRACTOR further represents that it is in good standing in and qualified to do business in the State of Texas.

CITY Ordinance Compliance and Certification. CONTRACTOR represents that CONTRACTOR has fully read and understood the terms and conditions for eligibility to contract with the CITY pursuant to Chapter 38 of the CITY'S Code of Ordinances and by entering into this Agreement certifies that CONTRACTOR is qualified to contract with the CITY compliance with all applicable requirements.

Texas Government Code Compliance. CONTRACTOR acknowledges that the CITY may not enter into an Agreement with a company for goods and services unless the Agreement contains a written verification from the company that; (i) it does not Boycott Israel; and (ii) will not Boycott Israel during the term of the contract. (Texas Government Code, Chapter 2270). CONTRACTOR, by entering into this Agreement, hereby verifies and certifies that it does not Boycott Israel and agrees that during the term of this Agreement will not Boycott Israel as that term is defined in the Texas Government Code Section 808.001, as amended.

Certificate of Interested Parties (TEC Form 1295). CONTRACTOR acknowledges that for contracts needing CITY Council approval, the CITY may not accept or enter into a contract until it has received from the CONTRACTOR a completed, signed, and notarized TEC Form 1295 complete with a certificate number assigned by the Texas Ethics Commission (“TEC”), pursuant to Texas Government Code § 2252.908 and the rules promulgated thereunder by the TEC. CONTRACTOR understands that failure to provide said form complete with a certificate number assigned by the TEC may prohibit the City from entering into this Agreement. Pursuant to the rules prescribed by the TEC, the TEC Form 1295 must be completed online through the TEC’s website, assigned a certificate number, printed, signed and notarized, and provided to the CITY. The TEC Form 1295 may accompany the bid or may be submitted separately but must be provided to the CITY prior to the award of this Agreement. Neither the City nor its Design Consultant have the ability to verify the information included in a TEC Form 1295, and neither have an obligation nor undertake responsibility for advising CONTRACTOR with respect to the proper completion of the TEC Form 1295.

Assignment of Contract. No assignment by a party hereto of any rights under or interests in the Contract will be binding on another party hereto without the written consent of the party sought to be bound in accordance with the General Conditions.

Successors and Assigns. CITY and CONTRACTOR each binds itself, its partners, successors, assigns, and legal representatives to the other party hereto, its partners, successors, assigns, and legal representatives in respect to all covenants, agreements, and obligations contained in the Contract Documents.

Severability. Any provision or part of the Contract Documents held to be void or unenforceable under any Law or Regulation shall be deemed stricken, and all remaining provisions shall continue to be valid and binding upon CITY and CONTRACTOR, who agree that the Contract Documents shall be reformed to replace such stricken provision or part thereof with a valid and enforceable provision that comes as close as possible to expressing the intention of the stricken provision.

Remainder of this Page left Intentionally Blank.

In consideration for the mutual obligations, representations, terms and conditions herein recited, CITY and CONTRACTOR have agreed to and signed this Agreement to be effective on _____, (Effective Date).

CITY OF PFUGERVILLE, TEXAS:

CONTRACTOR:

SA Smart Solutions, LLC

By: _____

By: Andrew Berteaux, Managing Partner

Sereniah Breland, City Manager

Name/Title

Attest _____

Attest _____

Trista Evans, City Secretary

By: Dennis Sullivan, Director of Operations

Name/Title

Address for giving notices:

Address for giving notices:

8610 N New Braunfels Ave Sutie 302

Pflugerville, Texas 78660

San Antonio, TX, 78217

CITY'S Designated Representative:

CONTRACTOR'S Designated Representative:

Name: Steven C. Johns

Name: Andrew Berteaux

Title: Project Manager

Title: Managing Partner

Address: 6102 Imperial Loop Dr.

Address: 8610 N New Braunfels Ave Sutie 302

College Station, TX 77845

San Antonio, TX, 78217

Phone/Fax: (979) 690-6555

Phone/Fax: 210.628.9024 / N/A

Email: Steven.Johns@hmttank.com

Email: andrew@satxsmart.com

**STATUTORY
PERFORMANCE
BOND**

STATE OF TEXAS §
COUNTY OF TRAVIS §
CITY OF PFLUGERVILLE §

The City of Pflugerville, a municipal corporation in the State of Texas (hereafter referred to as “City” or “Owner”) and _____, a _____ with its principal place of business located at _____ (hereafter referred to as “Contractor” or “Principal”) have entered into a Contract (hereafter referred to as “the Contract”) dated _____, 20__ for the Historic EST Lighting Project Project (hereafter referred to as “the Project”). Said Contract is incorporated by reference into this Statutory Performance Bond, pursuant to Chapter 2253 of the Texas Government Code (hereafter referred to as “this Bond”).

By virtue of this Bond, Contractor as Principal and _____ with its physical address at _____, a mailing address of _____ and a business telephone number of _____ as Surety (hereafter referred to as “Surety”) do hereby acknowledge each to be bound to Owner as an Obligee in the maximum penal amount of _____ Dollars (\$ _____), which represents one hundred percent (100%) of the Contract amount (hereafter referred to as the “Bond Sum”). Contractor and Surety hereby further bind themselves, their heirs, executors, administrators, successors and assigns, jointly and severally for payment of this Bond, to City as provided herein.

1. **GENERAL CONDITIONS.** It is a condition of this Bond that if Contractor promptly performs its Contract obligations (hereafter referred to as the “Work”), **including without limitation its warranty obligations established under the Contract**, Surety’s obligations pursuant to this Bond are null and void. Otherwise, Surety’s obligations shall remain in full force and effect. Surety waives any requirement to be notified of alterations or extensions of time, or any other duly authorized modifications, made by City to the Contract. Surety acknowledges and agrees that this Bond is being furnished to comply with Texas Government Code, Chapter 2253 and that any and all provisions provided in said statute are incorporated herein by reference. Any conflicts between this Bond and Texas Government Code, Chapter 2253 shall be resolved in favor of said statute. Upon making demand on this Bond, City shall make the Contract balance (equal to the total amount payable by City to Contractor pursuant to the Contract less amounts paid by City to Contractor), if any, available to Surety for completion of the Work.

2. **SURETY OBLIGATION.** If Contractor does not faithfully construct and complete said Work or honor its warranty obligations, as defined and established under its Contract with City, and City invokes its contractual rights and declares Contractor in default, Surety promptly shall remedy the default and, at City’s sole option, Surety shall:
 - A. Within a reasonable time (but not later than fifteen (15) days after Surety receives written notice of Contractor’s/Principal’s Default), with written notice to City, step into and assume the role, all rights and all obligations of the defaulting Contractor/Principal under the Contract, including without limitation, responsibilities for the correction of defective work completed by the Contractor, additional legal, design professional and delay costs resulting from Contractor’s default or resulting from Surety’s actions or failure to act under the terms of this Bond, and liquidated damages provided under the Contract. Upon assumption of this role, Surety and all sureties directly shall contract with a Completion Contractor hired/engaged by Surety and all sureties to complete the structure(s), Work and

improvements, pursuant to the Contract with Contractor/Principal. The selection of the Completion Contractor must be approved in writing by City and such approval shall not unreasonably delayed, conditioned or withheld. Surety and all sureties solely shall be responsible for any and all costs incurred, up to the Bond Sum, to complete the structure(s), Work and improvements, or satisfy any warranty obligation pursuant to the Contract with Contractor/Principal; or

B. In the event Surety fails to contract with a Completion Contractor within sixty (60) days of receipt of City's written notice of Default, City may, at City's sole discretion, select a Completion Contractor in accordance with Texas Law and in accordance with the provisions of the Contract. In this event of Surety and all sureties failing to contract with a Completion Contractor within sixty (60) days of receipt of City's written notice of Default, Surety and all sureties then shall pay City any and all costs, up to the Bond Sum, for City's selected Completion Contractor to complete the structure(s), Work and improvements, or honor Contractor's warranty obligations, as defined and established in accordance with the provisions of the Contract with Contractor/Principal.

3. **QUALIFICATION.** Surety companies executing this Bond must appear on the United States Treasury Department's most current list (Circular 570, as amended) and be otherwise authorized to transact business in the State of Texas.
4. **VENUE.** The obligations of the parties under this Bond shall be performable in Travis County, Texas and shall be construed under the laws of the State of Texas. If legal action, such as civil litigation, is necessary in connection with this Bond, exclusive venue shall be in Travis County, Texas.

THIS BOND is entered into this _____ day of _____, 20____.

SURETY (seal)

CONTRACTOR

By: _____
(Signature)

By: _____
(Signature)

(Print Name)

(Print Name)

(Print Title)

(Print Title)

[ATTACH POWER OF ATTORNEY]

[Additional signatures, if any, appear on
attached page]

ATTEST: _____

ATTEST: _____

**STATUTORY
PAYMENT BOND**

STATE OF TEXAS §
COUNTY OF TRAVIS §
CITY OF PFLUGERVILLE §

The **City of Pflugerville**, a municipal corporation in the State of Texas (hereafter referred to as “City”) and _____, a _____ with its principal place of business located at _____ (hereafter referred to as “Contractor” or “Principal”) have entered into a Contract (hereafter referred to as “the Contract”) dated the ___ day of _____, 20_ for the Historic EST Lighting Project Project (hereafter referred to as “the Project”). Said Contract is incorporated by reference into this Statutory Payment Bond, pursuant to Chapter 2253 of the Texas Government Code (hereafter referred to as “this Bond”).

By virtue of this Bond, Contractor as Principal and _____, with its physical address located at _____, a mailing address of _____ and a business telephone number of _____ as Surety (hereafter referred to as “Surety”) do hereby acknowledge each to be bound to City as an Obligee in the maximum penal amount of _____ Dollars (\$_____), which represents one hundred percent (100%) of the Contract amount (hereafter referred to as the “Bond Sum”). Contractor and Surety hereby further bind themselves, their heirs, executors, administrators, successors and assigns, jointly and severally for payment of this Bond, as provided herein.

1. **GENERAL CONDITIONS.** It is a condition of this Bond that if Contractor promptly makes payment of all sums for all labor, services, materials and equipment furnished for use in the performance of the work required by the Contract, Surety’s obligations pursuant to this Bond are null and void. Otherwise, Surety’s obligations shall remain in full force and effect. Surety waives any requirement to be notified of alterations or extensions of time, or any other duly authorized modifications or changes, made by City to the Contract. Surety acknowledges and agrees that this Bond is being furnished to comply with Texas Government Code, Chapter 2253 and that any and all provisions provided in said statute are incorporated herein by reference. Any conflicts between this Bond and Texas Government Code, Chapter 2253 shall be resolved in favor of said statute.
2. **SURETY OBLIGATION.** Surety’s obligation under this Bond is for the benefit and sole protection of all persons supplying labor, services, materials and equipment in the prosecution of said Contract (collectively, the “Claimant(s)”). Surety’s obligation to the Claimant(s) shall not exceed the Bond Sum.
3. **QUALIFICATION.** Surety companies executing this Bond must appear on the United States Treasury Department’s most current list (Circular 570, as amended) and be authorized to transact business in the Texas, hold a certificate of authority from the United States Secretary of the Treasury to qualify as a surety on obligations permitted or required under federal law, and/or be otherwise

qualified to act as a Surety under Texas Insurance Code, Chapter 3503.

4. **VENUE.** The obligations of the parties under this Bond shall be performable in Travis County, Texas and shall be construed under the laws of the State of Texas. If legal action, such as civil litigation, is necessary in connection with this Bond, exclusive venue shall be in Travis County, Texas.

THIS BOND is entered into this ____ day of _____, 20__.

SURETY (seal)

CONTRACTOR

By: _____
(Signature)

By: _____
(Signature)

(Print Name)

(Print Name)

(Print Title)

(Print Title)

[ATTACH POWER OF ATTORNEY]

[Additional signatures, if any, appear on
attached page]

ATTEST: _____

ATTEST: _____



WARRANTY BOND

Warranty Bond for

_____ (Name of Plans)

Date: _____

Penal Sum: \$ _____ and _____/100
U.S. Dollars

OBLIGEE:
City of Pflugerville
PO Box 589
Pflugerville, Texas 78691
(512) 990-6300

PRINCIPAL:
Name: _____
Address: _____
Phone: _____ (_____)

SURETY:
Name: _____
Address: _____
Phone: _____ (_____)

KNOW ALL BY THESE PRESENTS,

That we _____ as
Principal, and

_____, a
Corporation of the State of _____, authorized to write Surety Bonds in the State
of Texas, as Surety, are jointly and severally held and firmly bound unto the City of Pflugerville,
Texas as Obligee, in the Penal Sum of
_____ (\$ _____)

(Insert written amount = 35% of the cost of the improvements inspected)

which payment well and truly to be made we do bind ourselves, our and each of our heirs, executors, administrators, successors, and assigns jointly and severally, firmly by these presents.

WHEREAS, the said Principal has constructed, or caused to be constructed the following public infrastructure (“Improvements”) in accordance with the approved construction plans:

(Legal Description and items to be warranted [i.e. Streets, Drainage, Water, Wastewater, etc.]

WHEREAS, the City of Pflugerville requires the Principal to furnish a Warranty Bond in the amount of 35% of the cost of the Improvements guarantying all workmanship and materials used to construct the Improvements are free from any defect for a (1) one year period beginning at the date of acceptance. The Warranty Bond guarantees that the Principal will repair, or cause to be repaired, to the original condition at acceptance for (1) one year from the date of acceptance by the City of Pflugerville (“Warranty Period”), all defects in workmanship and material including any deterioration resulting from any defects in workmanship and materials of the Improvements, which may become apparent during the Warranty Period.

NOW, THEREFORE, THE CONDITIONS OF THIS OBLIGATION ARE SUCH that,

1. The foregoing recitals and statements are each and all true and correct.
2. Whenever Principal shall be, and is declared by the Oblige to be, in default with respect to its warranty of the Improvements, provided that the Oblige is not then in material default thereunder, Surety shall promptly take one of the following actions with the consent of the Oblige:
 - a. Not later than thirty (30) days following Surety’s receipt of written notice that the Principal had failed or refused to correct or repair the defects, Surety shall commence and complete construction, re-construction, replacement or repair of the Public Improvements in accordance with the City’s Unified Development Code, the City’s Engineering Design Guidelines and Construction Standards, and the City-approved construction plans for the Public Improvements (the “Plans”) applicable to the original construction; or
 - b. Notify the City if writing, not later than thirty (30) days following Surety’s receipt of written notice that the Principal has failed or refused to correct or repair the defects that the Surety elects not to complete, re-construct, replace or repair the Public Improvements. The Surety shall be obligated to pay the City, within the Penal Sum of the Bond, all loss, cost, and expense occasioned thereby. If the Surety fails to give such written notice, then it will be deemed to have elected not to complete, re-construct, replace, repair the Public Improvements, and shall be obligated to pay the City, within the Penal Sum of the Bond for all loss, cost, and expense occasioned thereby to complete, re-construct, replace or repair the Improvements.

In the event that Surety elects to proceed under 2(a) above, the contractor selected by Surety to perform such work shall be approved by Obligee, which approval shall not be unreasonably withheld.

3. If Surety does not proceed as provided in Paragraph 2 with reasonable promptness, Surety shall be deemed to be in default on this Bond fifteen days after receipt of an additional written notice from the Obligee to Surety demanding that Surety perform its obligations under this Bond, and the Obligee shall be entitled to enforce any remedy available to the Obligee. If Surety proceeds as provided in Subparagraph 2.b, and the Obligee refuses the payment tendered or Surety has denied liability, in whole or in part, without further notice, the Obligee shall be entitled to enforce any remedy available to the Obligee.
4. After the Obligee has terminated the Principal's right to complete corrections of all defects in materials or workmanship, and if Surety elects to act under Subparagraph 2.a. or b., above, then the responsibilities of Surety to the Obligee shall not be greater than those of the Principal under the Agreement, and the responsibilities of the Obligee to Surety shall not be greater than those of the Obligee under the Agreement. To the limit of the Penal Sum to mitigate costs and damages on the Agreement, Surety is obligated without duplication for:
 - a. the responsibilities of the Principal for correction of defective work; and
 - b. actual damages, including but not limited to additional legal and design professional costs resulting from Principal's default, and resulting from the actions or failure to act of Surety under Paragraph 2.
5. No alteration, modification or supplement to the Warranty or the nature of the work to be performed thereunder, including without limitation any extension of time for performance, shall in any way affect the obligations of Surety under this bond. Surety waives notice of any alteration, modification, supplement or extension of time.
6. The Principal and Surety shall not have any obligations under this Bond to correct, repair or replace any damage to the Improvements caused by any third parties or damage resulting from lack of proper maintenance of the Improvements.
7. The obligations of the Principal and the Surety under this Bond does not include any obligation to maintain the Improvements.
8. The obligations of the Principal and Surety under this Bond shall terminate at the end of the Warranty Period and, at that time, this Bond shall become void and shall be of no further force or effect.

Signed, sealed and dated this _____ day of _____, 20_____.

PRINCIPAL:

Date: _____

By: _____

Name: _____

Title: _____

SURETY:

Date: _____

By: _____

Name: _____

Title: _____

**GENERAL CONDITIONS FOR
CITY OF PFLUGERVILLE CIP CONSTRUCTION CONTRACTS**

ARTICLE I. GENERAL PROVISIONS 4

1.1 CONTRACT DEFINITIONS.....

1.2 PRELIMINARY MATTERS

1.3 CONTRACT DOCUMENTS.....

ARTICLE II. CITY 11

2.1 GENERAL.....

2.2 INFORMATION AND SERVICES TO BE PROVIDED BY CITY

ARTICLE III. CONTRACTOR..... 12

3.1 GENERAL

3.2 REVIEW OF CONTRACT DOCUMENTS AND FIELD CONDITIONS BY CONTRACTOR

3.3 SUPERVISION AND CONSTRUCTION PROCEDURES.....

3.4 LABOR AND MATERIALS

3.5 WARRANTY

3.6 TAXES.....

3.7 PERMITS, FEES AND NOTICES

3.8 ALLOWANCES

3.9 SUPERINTENDENT/KEY PERSONNEL

3.10 CONTRACTOR’S PROJECT SCHEDULES.....

3.11 DOCUMENTS AND SAMPLES AT THE SITE

3.12 SHOP DRAWINGS,PRODUCE DATA AND SAMPLES.....

3.13 ACCESS TO WORK

3.14 PATENT FEES AND ROYALTIES.....

3.15 INDEMNITY PROVISIONS.....

3.16 REPRESENTATIONS AND WARRANTIES

ARTICLE IV. ADMINISTRATION OF THE CONTRACT 33

4.1 DESIGN CONSULTANT.....

4.2 ROLES ADMINISTRATION OF THE CONTRACT

4.3 CLAIMS AND DISPUTES.....

4.4 RESOLUTION OF CLAIMS AND DISPUTES.....

4.5 ALTERNATIVE DISPUTE RESOLUTION

ARTICLE V. SUBCONTRACTORS 41

5.1 DEFINITION

5.2 AWARD OF SUBCONTRACTS AND OTHER CONTRACTS FOR PORTIONS OF THE WORK

5.3 SUB-CONTRACTUAL RELATIONS

5.4 CONTINGENT ASSIGNMENT OF SUBCONTRACTS

ARTICLE VI. CONSTRUCTION BY CITY OR BY SEPARATE CONTRACTS 43

6.1 CITY’S RIGHT TO PERFORM CONSTRUCTION AND TO AWARD SEPARATE CONTRACTS

6.2 MUTUAL RESPONSIBILITY

6.3 CITY’S RIGHT TO CLEAN UP

ARTICLE VII. CHANGES IN THE WORK 44

7.1 GENERAL

7.2	CHANGE ORDERS	
7.3	FIELD WORK DIRECTIVES	
7.4	ORDER FOR MINOR CHANGES TO THE WORK	
7.5	TIME REQUIRED TO PROCESS CHANGE ORDERS	
ARTICLE VIII. TIME		48
8.1	PROGRESS AND COMPLETION	
8.2	DELAYS AND EXTENSIONS OF TIME	
ARTICLE IX. PAYMENTS AND COMPLETION		50
9.1	CONTRACT SUM	
9.2	SCHEDULE OF VALUES	
9.3	APPLICATIONS FOR PAYMENT	
9.4	PAY APPLICATION APPROVAL	
9.5	DECISIONS TO REJECT APPLICATION FOR PAYMENT	
9.6	PROGRESS PAYMENTS	
9.7	SUBSTANTIAL COMPLETION	
9.8	PARTIAL OCCUPANCY OR USE	
9.9	FINAL COMPLETION AND FINAL PAYMENT	
9.10	ADDITIONAL INSPECTIONS	
ARTICLE X. PROTECTION OF PERSONS AND PROPERTY		56
10.1	SAFETY PRECAUTIONS AND PROGRAMS	
10.2	SAFETY OF PERSONS AND PROPERTY	
10.3	EMERGENCIES	
10.4	PUBLIC CONVENIENCE AND SAFETY	
10.5	PUBLIC UTILITIES AND OTHER PROPERTIES TO BE CHANGED	
10.6	ARRANGEMENT AND CHARGE FOR WATER FURNISHED BY CITY/ELECTRICITY FOR THE PROJECT/WIRELESS ACCESS	
10.7	ENVIRONMENTAL COMPLIANCE	
10.8	ROAD CLOSURES AND DETOUR ROUTES	
10.9	USE OF CITY STREETS	
10.10	MAINTENANCE OF TRAFFIC	
10.11	ABATEMENT AND MITIGATION OF EXCESSIVE OR UNNECESSARY CONSTRUCTION NOISE	
10.12	INCIDENTAL WORK, CONNECTIONS, AND PASSAGEWAYS	
ARTICLE XI. INSURANCE AND BONDS		61
11.1	CONTRACTOR'S LIABILITY INSURANCE	
11.2	PROPERTY INSURANCE	
11.3	PERFORMANCE, PAYMENT AND WARRANTY BONDS	
11.4	'UMBRELLA' LIABILITY INSURANCE	
11.5	POLICY ENDORSEMENTS AND SPECIAL CONDITIONS	
ARTICLE XII. INSPECTING, UNCOVERING AND CORRECTING OF WORK		69
12.1	INSPECTING WORK	
12.2	UNCOVERING WORK	
12.3	CORRECTING WORK	
12.4	ACCEPTANCE OF NONCONFORMING WORK	
ARTICLE XIII. COMPLETION OF THE CONTRACT; TERMINATION; TEMPORARY SUSPENSION.....		70

- 13.1 FINAL COMPLETION OF CONTRACT
- 13.2 WARRANTY FULFILLMENT
- 13.3 TERMINATION BY CITY FOR CAUSE/CONVENIENCE
- 13.4 TEMPORARY SUSPENSION OF THE WORK

ARTICLE XIV. MISCELLANEOUS PROVISIONS 74

- 14.1 GOVERNING LAW; COMPLIANCE WITH LAWS AND REGULATIONS
- 14.2 SUCCESSORS AND ASSIGNS
- 14.3 WRITTEN NOTICE
- 14.4 RIGHTS AND REMEDIES; NO WAIVER OF RIGHTS BY CITY
- 14.5 INTEREST
- 14.6 INDEPENDENT MATERIALS TESTING AND INSPECTION
- 14.7 COMPLIANCE WITH CHAPTER 38 OF THE CITY'S CODE OF ORDINANCES
- 14.8 VENUE
- 14.9 INDEPENDENT CONTRACTOR
- 14.10 TEXAS GOVERNMENT CODE
- 14.11 GIFTS TO PUBLIC SERVANTS

ARTICLE XV. AUDIT 75

- 15.1 RIGHT TO AUDIT CONTRACTOR'S RECORDS

ARTICLE XVI. ATTORNEY FEES 76

**GENERAL CONDITIONS FOR
CITY OF PFLUGERVILLE CIP CONSTRUCTION CONTRACTS**

ARTICLE I. GENERAL PROVISIONS

1.1 CONTRACT DEFINITIONS

Wherever used in the Contract Documents and printed with initial capital letters, the terms listed below shall have the meanings indicated, which are applicable to both the singular and plural thereof.

- 1.1.1 “**ALTERNATE**” means a variation in the Work in which City requires a price separate from the Base Bid. If an Alternate is accepted by City, the variation shall become a part of the Contract through award of the Contract and the Base Bid shall be adjusted to include the amount quoted as stated in the Notice of Award to Contractor. If an Alternate is accepted by City, and later deleted, City shall be entitled to a credit in the full value of the Alternate as priced in Contractor’s Bid Proposal.
- 1.1.2 “**AMENDMENT**” is a written modification of the Contract prepared by City or Design Consultant and signed by City and Contractor, (and approved by the Pflugerville City Council, if required) which authorizes an addition, deletion or revision in the Work (specifically the services) or an adjustment in the Contract Sum or the Contract Times and is issued on or after the Effective Date of the Contract.
- 1.1.3 “**BASE BID**” is the price quoted for the Work before Alternates are considered.
- 1.1.4 “**CHANGE ORDER**” refer to **Article VII** herein for definition.
- 1.1.5 “**CITY**” is defined in **Article II** herein.
- 1.1.6 “**CITY COUNCIL**” means the duly elected members of the City Council of the City of Pflugerville, Texas.
- 1.1.7 “**CONSTRUCTION OBSERVER/INSPECTOR**” (hereafter referred to as “COI”) is the authorized representative of the City, or its designee department, assigned by City to observe and inspect any or all parts of the Project and the materials to be used therein. Also referred to herein as Resident Inspector.
- 1.1.8 “**CONTRACT**” means the Contract Documents which represent the entire and integrated agreement between City and Contractor and supersede all prior negotiations, representations or agreements, either written or oral. The terms and conditions of the Contract Documents may be changed only in writing by a Field Work Directive, Change Order or Amendment. The Contract Documents shall not be construed to create a contractual relationship of any kind between: 1) Design Consultant and Contractor; 2) City and a Subcontractor or Sub-Subcontractor; or 3) any persons or entities other than City and Contractor.
- 1.1.9 “**CONTRACT DOCUMENTS**” means the Construction Contract between City and Contractor, which consists of, but is not limited to, the following: the solicitation (bidding) documents, including the various contract-based certifications, the Notice of Award, an enabling City of Pflugerville Resolution, if applicable, and all other contract-related documents, which include:
- (1) Standard CIP Construction Agreement;
 - (2) General Conditions for CIP Construction Contracts;
 - (3) Vertical and/or Horizontal specific Special Conditions for CIP Construction Contracts, if

- included;
- (4) Drawings;
 - (5) Specifications;
 - (6) addenda issued prior to the close of the solicitation period;
 - (7) other documents listed in the Contract, including Field Work Directives, Change Orders and/or Amendments, Notice to Proceed, performance and payment bonds; and
 - (8) a written order for a minor change in the Work issued by Design Consultant and/or City, as described in **Article VII** herein.

The geotechnical and subsurface reports, which City may have provided to Contractor, if any, specifically are excluded from the Contract Documents.

- 1.1.10 **“CONTRACT TIME”** means, unless otherwise provided, the period of time, including any authorized adjustments, allotted in the Contract Documents for Substantial and/or Final Completion of the Work. Contract Time or Times also refers to Milestones designated in **Section II** of the City of Pflugerville Standard Capital Improvement Project (CIP) Construction Agreement Between City and Contractor and reflected in the Work Progress Schedule.
- 1.1.11 **“CONTRACTOR”** means the entity entering into a Contract with City to complete the Work. Contractor, as used herein, includes Construction Manager at Risk or other applicable entities performing work under a Contract with City.
- 1.1.12 **“DAY”** as used in the Contract Documents shall mean Calendar Day, unless otherwise specifically defined. A Calendar Day is a day of 24 hours, measured from midnight to the next midnight, unless otherwise specifically stipulated.
- 1.1.13 **“DEPARTMENT”** means the designated Department of the City of Pflugerville, Texas for Contract management purposes.
- 1.1.14 **“DESIGN CONSULTANT”** means, unless the context clearly indicates otherwise, an Engineer, Architect or other Design Consultant in private practice, licensed to do work in Texas and retained for a specific project under a contractual agreement with City.
- 1.1.15 **“DRAWINGS”** (also referred to herein as **“PLANS”**) are the graphic and pictorial portions of the Contract Documents, wherever located and whenever issued, showing the design, location and dimensions of Work, generally including elevations, sections, details, schedules and diagrams.
- 1.1.16 **“FIELD WORK DIRECTIVES” OR “FORCE ACCOUNT”** is a written order signed by City directing a change in the Work prior to agreement and adjustment, if any, in the Contract Sum and/or Contract Time, as further defined in **Section 7.3** herein.
- 1.1.17 **“HAZARDOUS SUBSTANCE”** is defined to include the following:
- (a) any asbestos or any material which contains any hydrated mineral silicate, including chrysolite, amosite, crocidolite, tremolite, anthophyllite or actinolite, whether friable or non-friable;
 - (b) any polychlorinated biphenyls (“PCBs”), or PCB-containing materials, or fluids;
 - (c) radon;
 - (d) any other hazardous, radioactive, toxic or noxious substance, material, pollutant, or solid, liquid or gaseous waste; any pollutant or contaminant (including but not limited to petroleum, petroleum hydrocarbons, petroleum products, crude oil or any fractions

thereof, any oil or gas exploration or production waste, any natural gas, synthetic gas or any mixture thereof, lead, or other toxic metals) which in its condition, concentration or area of release could have a significant effect on human health, the environment, or natural resources;

- (e) any substance, whether by its nature or its use, is subject to regulation or requires environmental investigation, monitoring, or remediation under any federal, state, or local environmental laws, rules, or regulations;
- (f) any underground storage tanks, as defined in 42 U.S.C. Section 6991(1)(A)(I) (including those defined by Section 9001(1) of the 1984 Hazardous and Solid Waste Amendments to the Resource Conservation and Recovery Act, 42 U.S.C. Section 6901 et seq.; the Texas Water Code Annotated Section 26.344; and Title 30 of the Texas Administrative Code Sections 334.3 and 334.4), whether empty, filled or partially filled with any substance; and
- (g) any other hazardous material, hazardous waste, hazardous substance, solid waste, and toxic substance as those or similar terms are defined under any federal, state, or local environmental laws, rules, or regulations.

- 1.1.18 **“LIQUIDATED DAMAGES”** reflect the daily monetary compensation, as designated in the City’s Standard Capital Improvement Project (CIP) Construction Agreement Between City and Contractor, to be paid to City by Contractor for losses/damages incurred by City as a result of the Contractor’s failure to achieve the contractual dates for Substantial Completion and/or Final Completion of the Project.
- 1.1.19 **“MILESTONE”** means a date certain established by **Section II** of the City of Pflugerville Standard Capital Improvement Project (CIP) Construction Agreement Between City and Contractor that establishes a substantial and/or final completion date of a portion of the Work prior to completion of the entirety of the Work.
- 1.1.20 **“NOTICE TO PROCEED (HEREIN ALSO REFERRED TO AS “WORK PROJECT AUTHORIZATION” OR “NTP”)**” is a written notice given by City to Contractor establishing the date on which the Contract Time shall commence to run and the date on which Contractor may begin performance of its contractual obligations.
- 1.1.21 **“OWNER”** is defined in **Article II** herein.
- 1.1.22 **“OWNER’S DESIGNATED REPRESENTATIVE (ODR)”** means the person(s) designated by City to act for City.
- 1.1.23 **“PARTY”** shall refer to City or Contractor individually herein.
- 1.1.24 **“PARTIES”** shall refer to City and Contractor collectively herein.
- 1.1.25 **“PROJECT”** means the total design and construction of Work performed under the Contract Documents and may be the whole or a part of the Project and which may include construction by City or by separate contractors. All references in these General Conditions to or concerning the Work or the Site of the Work shall use the term “Project,” notwithstanding the Work referenced may only be a part of the Project.
- 1.1.26 **“PROJECT MANAGEMENT TEAM”** is composed of City, its representatives, Design Consultant and Program Manager (if any) for this Work.
- 1.1.27 **“SITE”** means the land(s) or area(s) (as indicated in the Contract Documents) furnished by City, upon

which the Work is to be performed, including rights-of-way and easements for access thereto, and such other lands furnished by City which are designated for the use of Contractor.

- 1.1.28 **“SPECIAL CONDITIONS”** are terms and conditions to a contractual agreement which supplement and are superior to these General Conditions and grant greater authority or impose greater restrictions upon Contractor, beyond those granted or imposed in these General Conditions.
- 1.1.29 **“SPECIFICATIONS”** are those elements of the Contract Documents consisting of the written requirements for materials, equipment, construction systems, standards, workmanship for the Work, performance of related services and other technical requirements.
- 1.1.30 **“SUBSTANTIAL COMPLETION”** is the date certified by City and Design Consultant, in accordance with **Section 9.7** herein, when the Work, or a designated portion thereof, is sufficiently complete in accordance with the Contract Documents so as to be operational and fit for the intended use by City.
- 1.1.31 **“TEMPORARY BENCH MARKS (TBM)”** are temporary affixed marks which establish the exact elevation of a place; TBMs are used by surveyors in measuring site elevations or as a starting point for surveys.
- 1.1.32 **“WORK”** means the construction and services required by the Contract Documents, whether completed or partially completed, and includes all labor, materials, equipment and services provided or to be provided by Contractor, or any Subcontractors, Sub-Subcontractors, material suppliers or any other entities for which Contractor is responsible, to fulfill the Contractor’s obligations. The Work may constitute the whole or a part of the Project.
- 1.1.33 **OTHER DEFINITIONS.** As used in the Contract Documents, the following additional terms have the following meanings:
- (a) “provide” means to furnish, install, fabricate, deliver and erect, including all services, materials, appurtenances and all other expenses necessary to complete in place and ready for operation or use;
 - (b) “shall” or “will” means the mandatory action of the Party of which reference is being made;
 - (c) “as required” means as prescribed in the Contract Documents; and
 - (d) “as necessary” means all action essential or needed to complete the work in accordance with the Contract Documents and applicable laws, ordinances, construction codes and regulations.

1.2 PRELIMINARY MATTERS

- 1.2.1 **NOTICE OF AWARD.** Upon the Pflugerville City Council’s formal authorization to issue a contract, a Notice of Award Letter shall be sent to Contractor by the applicable City Department or ODR, notifying Contractor of the award of a contract. In its Notice of Award Letter, Contractor shall be informed of a date certain by which Contractor’s bond(s) and evidence of insurance shall be delivered to the Department or ODR.
- 1.2.2 **DELIVERY OF CONTRACT AND BONDS.** Contractor shall, in accordance with **Section 11.3 herein**, deliver a fully executed Contract to City, along with such bonds as Contractor may be required to furnish, including, but not limited to, required payment and performance bonds in the form and amount specified in the Contract Documents and these General Conditions.
- 1.2.3 **DELIVERY OF EVIDENCE OF INSURANCE.** Not later than the Pre-Construction meeting, and

prior to the commencement of any Work under this Contract, Contractor shall have delivered evidence of insurance to City in accordance with **Article XI** herein. Contractor shall have furnished an original completed Certificate of Insurance and a copy of all insurance policies, together with all required endorsements thereto, required by the Contract Documents to the City, or its delegated Department or ODR, clearly labeled with the name of the Project and which shall contain all information required by the Contract Documents. Contractor shall be prohibited from commencing the Work and City shall have no duty to pay or perform under this Contract until such evidence of insurance is delivered to City. No officer or employee, other than City's Risk Management Department, shall have authority to waive this requirement.

- 1.2.4 **NOTICE TO PROCEED AND COMMENCEMENT OF CONTRACT TIMES.** Unless otherwise stated on the Notice to Proceed, the Contract Time shall commence to run on the date stated on the Notice to Proceed. No Work shall commence any earlier than the date stated on Notice to Proceed and no Work shall be performed by Contractor or any Subcontractor prior to issuance of the Notice to Proceed. Any work commenced prior to Contractor receiving a Notice to Proceed is performed at Contractor's sole risk and expense.
- 1.2.5 **SUBMISSION OF PROJECT SCHEDULE(S).** Prior to commencement of any Work (unless otherwise specified elsewhere in the Contract Documents), Contractor shall submit to the ODR or Director of the Department or his/her designee the Project schedule(s), as defined in **Section 3.10** herein, a minimum of fifteen (15) days prior to the Pre-Construction Conference.
- 1.2.6 **PRE-CONSTRUCTION CONFERENCE.** Before Contractor commences any Work on the Project, a Pre-Construction Conference attended by Contractor, Design Consultant, City's Designated Representative(s) and others, as appropriate, shall be held to establish a working understanding among the Parties as to the Work and discuss, at minimum: the Project Schedule(s) referenced in this **Article 1**; the procedures for handling Shop Drawings and other submittals; the processing of Applications for Payment; and Contractor maintaining required records. The Notice to Proceed may be issued at the Pre-Construction Conference or issued by City at any time at City's discretion. Said issuance of the Notice to Proceed shall not be unreasonably withheld or delayed by City.
- 1.2.7 Payments for services, goods, work, equipment and materials are contingent upon and subject to the availability and appropriation of funds and/or the sale of future City of Pflugerville Certificates of Obligation and/or General Obligation Bonds in accordance with adopted budgets. In the event funds are not available, appropriated or encumbered to fund a Project, then, at City's discretion, this Contract may be terminated immediately with no additional liability to City.

1.3 CONTRACT DOCUMENTS

- 1.3.1 **EXECUTION OF CONTRACT DOCUMENTS.** Execution of the Contract by Contractor is a representation Contractor has been provided unrestricted access to the existing improvements and conditions on the Project Site, Contractor thoroughly has investigated the conditions at the Site and the general local conditions affecting the Work and Contractor's investigation was instrumental in preparing its bid or proposal submitted to City to perform the Work, upon which the City has justifiably relied upon when entering into this Contract. Contractor shall not make or be entitled to any claim for any adjustment to the Contract Time or the Contract Sum arising from conditions which Contractor discovered or, in the exercise of reasonable care, should have discovered in Contractor's investigation.
- 1.3.2 **OWNERSHIP AND USE OF DRAWINGS, SPECIFICATIONS AND OTHER INSTRUMENTS OF SERVICE.** The Drawings, Specifications and other documents, including those in electronic form, prepared by Design Consultant, its Consultants or other Consultants retained by City for the Project, which describe the Work to be executed by Contractor (collectively referred to as the "Construction Documents")

are and shall remain the property of City, whether the Project for which they are made is executed or not. Contractor shall be permitted to retain one record set. Neither Contractor nor any Subcontractor, sub-Subcontractor or material or equipment supplier shall own or claim a copyright in the Drawings, Specifications and other documents prepared by Design Consultant or Design Consultant's Consultants. All copies of Construction Documents, except Contractor's record set, shall be returned or suitably accounted for to Design Consultant on request and upon completion of the Work. The Drawings, Specifications and other documents prepared by Design Consultant and Design Consultant's Consultants, along with copies thereof furnished to Contractor, are for use solely with respect to this Project. The drawings, Specifications or other documents are not to be used by Contractor or any Subcontractor or material or equipment supplier on other projects or for additions to this Project outside the scope of the Work without the specific written consent of City. Any such use without written authorization shall be at the sole risk and liability of Contractor. Contractor, Subcontractors and material or equipment suppliers are authorized to use and reproduce applicable portions of the Drawings, Specifications and other documents prepared by the Design Consultant and the Design Consultant's Consultants appropriate to and for use in the execution of their Work under the Contract Documents. All copies made under this authorization shall bear the statutory copyright notice, if any, shown on the Drawings, Specifications and other documents prepared by Design Consultant and Design Consultant's Consultants. Submittal or distribution to meet official regulatory requirements or for other purposes, in connection with this Project, is not to be construed as publication.

1321 All of Contractor's non-proprietary, documentary Work product, including reports and correspondence to City, prepared pursuant to this Contract, shall be the property of City and, upon completion of this Contract and upon written request by City, promptly shall be delivered to City in a reasonably organized form, without restriction on its future use by City. For the avoidance of doubt, documentary Work product does not include privileged communications, proprietary information and documents used to prepare Contractor's Bid Proposal.

1322 Contractor may retain for its files any copies of documents it chooses to retain and may use its Work product as it deems fit. Any materially-significant Work product lost or destroyed by Contractor shall be replaced or reproduced at Contractor's non-reimbursable sole cost. In addition, City shall have access during normal business hours, during the duration this Contract is in effect and for four (4) years after the final completion of the Work, unless there is an ongoing dispute under the Contract, then such access period shall extend longer until final resolution of the dispute, to all of Contractor's records and documents covering reimbursable expenses, actual base hourly rates, time cards and annual salary escalation records maintained in connection with this Contract for purposes of auditing same at the sole cost of City. The purpose of any such audit shall be for the verification of such costs. Contractor shall not be required to keep records of, or provide access to, the makeup of any negotiated and agreed-to lump sums, unit prices or fixed overhead and profit multipliers. Nothing herein shall deny Contractor the right to retain duplicates. Refusal by Contractor to comply with the provisions hereof shall entitle City to withhold any payment(s) to Contractor until compliance is obtained.

1.3.3 **CORRELATION AND INTENT.** The intent of the Contract Documents is to include all items necessary for the proper execution and completion of the Work by Contractor. The Contract Documents are complementary and what is required by one shall be as binding as if required by all. Performance by Contractor shall be required only to the extent consistent with the Contract Documents and which reasonably is inferable from the Contract Documents as deemed necessary to produce the indicated results. Subject to this **Section 1.3.3** and the specific provisions of the subsections contained hereunder, with the exception of **Subsection 1.3.3.4**, should the Contract Documents be inconsistent in terms of quality and quantity of the Work indicated, Contract pricing shall be based on the better quality and greater quantity of work indicated as determined in the City's reasonable discretion. In cases of discrepancy between any drawing and the dimension figures written

thereon:

- (1) the dimension figures shall govern over scaled dimensions;
 - (2) Detailed Drawings and accompanying notations shall govern over general Drawings; and
 - (3) Specifications shall govern over Drawings, subject to this **Section 1.3.3** herein.
- 1331 Organization of the Specifications into divisions, sections, articles, and the arrangement of Drawings shall not control Contractor in dividing the Work among Subcontractors or establishing the extent of Work to be performed by any trade.
- 1332 Unless otherwise stated in the Contract Documents, words having well-known technical or construction industry meanings are used in the Contract Documents in accordance with such recognized meanings. Where the phrases "directed by", "ordered by" or "to the satisfaction of" City, Design Consultant or City's Resident Inspector or other specified designation occur, it is understood the directions, orders or instructions to which they relate are those within the scope of and authorized by the Contract Documents.
- 1333 Reference to manufacturer's instructions, standard specifications, manuals or codes of any technical society, organization or association, laws or regulations of any governmental authority, or to any other documents, whether such reference be specific or by implication, shall mean the latest standard specification, manual, code or laws or regulations in effect at the time of opening of Contractor's Bid Proposal, except as otherwise may be specifically stated or where a particular issue is indicated. Municipal and utility standards shall govern except in case of conflict with the Specifications. In case of a conflict between the Specifications and the referenced standard, the more stringent shall govern.
- 1334 The most recently issued Document takes precedence over previous issues of the same Document. In the event that a conflict exists between the various components of the Contract Documents, the order of precedence to resolve the conflict is as follows, with the highest authority listed herein as "(a)" and thereafter in descending order of authority:
- (a) Modifications or Amendments to the Project Contract signed by Contractor, City and Design Consultant;
 - (b) Addenda, with those of later date(s) having precedence over those with earlier date(s);
 - (c) Standard Capital Improvement Project (CIP) construction agreement
 - (d) Special Conditions for CIP Construction Contracts;
 - (e) General Conditions for CIP Construction Contracts;
 - (f) Special Provisions, if any;
 - (g) Specifications;
 - (h) Drawings; and
 - (i) Solicitation (bidding) documents.
- 1335 Reserved.
- 1336 In the Drawings and Specifications, where certain products, manufacturer's trade names or catalog numbers are given, such information is given for the sole and express purpose of establishing a standard of function, dimension, appearance and quality of design in harmony with the Work and is not intended for the purpose of limiting competition, unless specified as a sole source. Materials or equipment shall not be substituted unless such a substitution has been specifically accepted for use on this Project by City and Design Consultant.

- 1337 When the work is governed by reference to standards, building codes, manufacturer's instructions or other documents, unless otherwise specified, the edition currently in place as of the date of the submission of the Bid Proposal shall apply.
- 1338 Requirements of public authorities apply as minimum requirements only and do not supersede more stringent specified requirements.
- 1339 Special Provisions, if any, shall be issued by City directly to Contractor, shall become part of the Project Specifications and shall modify City's Standard Specifications.

ARTICLE II. CITY

2.1 GENERAL

- 2.1.1 The City of Pflugerville, Texas, a home-rule, Texas Municipal Corporation located in Travis and Williamson Counties and identified as "City" or as "Owner" in the Contract and these General Conditions, is referred to throughout the Contract Documents as if singular in number. City shall designate in writing to Contractor a representative (hereafter referred to as "City's Designated Representative" or "ODR") who shall act as the City's representative with respect to all matters concerning this Contract. Whenever the term "City" or "City" is found in this Contract or the Contract Documents, such term shall include City's agents, elected officials, employees, officers, directors, volunteers, representatives, successors and assigns.

2.2 INFORMATION AND SERVICES TO BE PROVIDED BY CITY

- 2.2.1 City shall provide and maintain the general schedule, if any, for the Project. The general schedule shall set forth City's plan for Milestone dates, Substantial Completion and Final Completion of the Project.
- 2.2.2 City shall furnish surveys, if in existence and in City's possession, describing physical characteristics, legal limitations and utility locations. The furnishing of these surveys and reports are for Contractor's convenience only and the City shall not be liable for any Contract Sum or Contract Time adjustment due to discrepancies therein found, unless otherwise specifically provided in the Contract Documents. Further, furnishing of said surveys and reports shall not relieve Contractor of any of its duties under the Contract Documents or these General Conditions. Information or services required of City by the Contract Documents shall be furnished by City with reasonable promptness following actual receipt of a written request from Contractor. It is incumbent upon Contractor to identify, establish and maintain a current schedule of latest dates for submittal and approval by City, as required in **Section 3.10** herein, including when such information or services must be delivered. If City delivers the information or services to Contractor as scheduled and Contractor is not prepared to accept or act on such information or services, then Contractor shall reimburse City for all extra costs incurred by holding, storage, retention or performance, including redeliveries by City in order to comply with the current schedule.
- 2.2.3 Unless otherwise provided in the Contract Documents, Contractor shall be furnished, free of charge, **up to two (2) complete sets** of the Plans and Specifications by Design Consultant. Additional complete sets of Plans and Specifications, if requested by Contractor, shall be furnished to Contractor at reproduction cost.
- 2.2.4 City's personnel may, but are not required to, be present at the construction site during progress of the Work, along with Design Consultant in the performance of its duties, to verify Contractor's record of the number of workers employed on the Work site, the workers' occupational classification, the time

each worker is engaged in the Work and the equipment used by the workers in the performance of the Work, for purpose of verification of Contractor's Applications for Payment and payroll records.

- 2.2.5 City shall reimburse Contractor for the necessary Project-related approvals, fees and required permits with no markup paid to Contractor for these necessary Project-related approvals, fees and required permits costs, unless said costs are stipulated in the Contract Documents as a part of Contractor's cost of Work.
- 2.2.6 **CITY'S RIGHT TO STOP THE WORK.** If Contractor fails to correct Work deemed by City not in accordance with the requirements of the Contract Documents, as required by **Section 12.3** herein, fails to carry out Work in accordance with the Contract Documents or fails to submit its preliminary or updated schedule(s), bond(s), insurance certificate(s) or any other required submittals, City may issue a written order to Contractor to stop the Work, or any portion thereof, until the cause for such order has been eliminated. The right of City to stop the Work shall not give rise to any duty on the part of City to exercise this right for the benefit of the Contractor or any other person or entity. This right shall be in addition to and not in restriction of City's rights pursuant to **Section 12.3** herein. City's issuance of an order to Contractor to stop the Work shall not give rise to any claim by Contractor for additional time, cost or general conditions costs.
- 2.2.7 **CITY'S RIGHT TO CARRY OUT THE WORK.** If Contractor defaults, neglects or fails to carry out the Work in accordance with the Contract Documents and fails, within a three (3) work-day period after receipt of written notice from City, to commence and continue correction of such default, neglect or failure with diligence and promptness, City may, without prejudice to other remedies City may have, correct such deficiencies, neglect or failure. In such case, an appropriate Change Order may be issued deducting from payments then or thereafter due Contractor reflecting the reasonable cost of correcting such deficiencies, neglect or failure of Contractor, including all of City's incurred expenses and compensation for Design Consultant's additional services made necessary by such default, neglect or failure of Contractor. If payments then or thereafter due Contractor are not sufficient to cover such amounts for the Work performed, Contractor shall pay the difference to City.

ARTICLE III. CONTRACTOR

3.1 GENERAL

- 3.1.1 Contractor is the person or entity identified as such in the Contract and is referred to throughout the Contract Documents as if singular in number. The term "Contractor" means the Contractor or the Contractor's authorized representative.
- 3.1.2 Contractor shall perform the Work in a good and workmanlike manner, except to the extent the Contract Documents expressly specify a higher degree of finish or workmanship.
- 3.1.3 Contractor shall not be relieved of its obligations, responsibilities or duties to perform the Work in accordance with the Contract Documents, either by any activities or duties of Design Consultant in Design Consultant's administration of the Contract or by tests, inspections or approvals required or performed by City or any person other than the Contractor.
- 3.1.4 *Work Week.* Unless otherwise superseded by the Special Conditions or revised in accordance with this **Section 3.1.4**, Site Work shall only be performed by the Contractor under this Contract from 6:00 a.m. to Dusk, Monday through Friday of each week, which shall be considered the Work Week for all purposes. Contract Times, however, shall be calculated solely on the basis of Calendar Days as

hereinabove defined and the designation of a Work Week shall have no bearing on these calculations. In the absence of Special Conditions extending or otherwise modifying the Work Week, in the event that Contractor desires to extend the Work Week for good cause shown, Contractor may request such extension detailing the reasons for such request in writing to the City. City shall consider said request and grant, modify or reject such request, in City's sole discretion, it being understood and agreed to by the parties hereto that the Contract Time factors in days not included within the Work Week for Work completion.

3.2 REVIEW OF CONTRACT DOCUMENTS AND FIELD CONDITIONS BY CONTRACTOR

321 Since the Contract Documents are complementary, before starting each portion of the Work, Contractor carefully shall:

- (1) study and compare the various Drawings and other Contract Documents relative to that portion of the Work and the information furnished by City;
- (2) take field measurements of any existing conditions related to that portion of the Work; and
- (3) observe any conditions at the Site affecting the Work.

Any error, inconsistencies or omissions discovered by Contractor shall be promptly reported to City via a Request for Information in such form as City may require.

321.1 The exactness of existing grades, elevations, dimensions or locations given on any Drawings issued by Design Consultant, or the work installed by other contractors, is not guaranteed by City. Contractor shall, therefore, satisfy itself as to the accuracy of all grades, elevations, dimensions and locations.

321.2 In all cases of interconnection of its Work with existing conditions or with work performed by others, Contractor shall verify at the site all dimensions relating to such existing or other work. Any errors due to Contractor's failure to so verify all such grades, elevations, dimensions or locations promptly shall be rectified by Contractor without any additional cost to City.

322 As between City and Contractor, and subject to the provisions of **Section 3.2.4** below, Contractor has no responsibility for the timely delivery, completeness, accuracy and/or sufficiency of the Specifications or Drawings (or any errors, omissions, or ambiguities therein), and is not responsible for any failure of the design of the facilities or structures as reflected thereon to be suitable, sound or safe. Contractor shall be deemed to have satisfied itself as to the design contained in and reflected by the Specifications and the Drawings. In particular, but without prejudice to the generality of the foregoing, Contractor shall review the Contract Documents to establish:

322.1 the information is sufficiently complete to perform the Work; and

322.2 there are no obvious or patent ambiguities, inaccuracies or inconsistencies within or between the documents forming the Contract; and

322.3 Contractor shall work with the aforementioned Contract Documents so as to perform the Work and of each and every part thereof to ensure the Work and each and every part thereof shall, jointly and severally, be in accordance with the requirements of the Contract Documents and, in particular but without limiting the generality of the foregoing, the Work as a whole and, as appropriate, each and every part thereof, shall comply with the requirements of any

performance Specifications.

323 Any design errors or omissions noted by Contractor during its review promptly shall be reported to City, but it is recognized the Contractor's review is made in Contractor's capacity as a contractor and not as a licensed design professional, unless otherwise specifically provided in the Contract Documents. Contractor is not required to ascertain if Contract Documents are in accordance with applicable laws, statutes, ordinances, building codes, and rules and regulations, but any nonconformity discovered by or made known to Contractor promptly shall be reported both to City and Design Consultant.

324 If Contractor believes additional cost or time is involved because of clarifications or instructions issued by Design Consultant, in response to the Contractor's Notices or Requests for Information, Contractor shall make Claims as provided in **Section 4.3** herein. If Contractor fails to perform the obligations of **Section 3.2.1** and **Section 3.2.2** herein, Contractor shall pay such costs and damages to City, to include applicable Liquidated Damages, as would have been avoided if Contractor had performed such obligations. Contractor shall not be liable to City or Design Consultant for damages resulting from errors, inconsistencies or omissions in the Contract Documents or for differences between field measurements or conditions and the Contract Documents, unless Contractor recognized or should have recognized such error, inconsistency, omission or differences and knowingly failed to report it to City and Design Consultant, as required by this **Section 3.2.4**.

325 **DIFFERING SITE CONDITIONS.** Contractor promptly shall, before such discovered conditions and/or structures are disturbed, notify City in writing of differing site conditions. Differing site conditions are defined as subsurface or latent physical and/or structural conditions at the Site differing materially from those indicated in the Plans, Specifications and other Contract Documents or newly discovered and previously unknown physical conditions at the Site of an unusual nature differing materially from those geophysical conditions typically encountered in the type Work being performed and generally being recognized as not indigenous to the Pflugerville, Travis County, Texas environs.

City and/or Design Consultant promptly shall investigate the reported physical and/or structural conditions and shall determine whether or not the physical and/or structural conditions do materially so differ and thereby cause an increase or decrease in Contractor's cost of and/or time required for performance of any part of the Work under this Contract. In the event City reasonably determines the physical and/or structural conditions materially so differ, a negotiated and equitable adjustment shall be made to the Contract Time and/or Contract Sum and a Change Order promptly shall be issued by City.

325.1 No claim of Contractor under this **Section 3.2.5** shall be allowed unless Contractor has given the written notice called for above, prior to disturbing the discovered conditions and/or structures.

325.2 No Contract adjustment shall be allowed under this **Section 3.2.5** for any effects caused on unchanged work.

3.3 SUPERVISION AND CONSTRUCTION PROCEDURES

331 Contractor shall supervise, inspect and direct the Work competently and efficiently, exercising the skill and attention of a reasonably prudent Contractor, devoting such attention and applying such skills and expertise as may be necessary to perform the Work in accordance with the Contract Documents. Contractor solely shall be responsible for the means, methods, techniques, sequences, procedures and coordination of all portions of the Work under the Contract, unless the Contract Documents give other

specific instructions concerning these matters. If the Contract Documents give specific instructions concerning construction means, methods and/or techniques, Contractor then shall evaluate the jobsite safety thereof and, except as stated herein below, shall be fully and solely responsible for the jobsite safety of such means, methods, techniques, sequences or procedures. If, upon its evaluation, Contractor determines such means, methods, techniques, sequences or procedures may not be safe, Contractor shall give timely written notice to City and Design Consultant and Contractor shall not proceed with that portion of the Work without further written instructions from City. Sequencing and procedures shall be coordinated and agreed upon by City, Design Consultant and Contractor.

332 Contractor shall be responsible to City for the acts and omissions of Contractor's agents and employees, Subcontractors and their agents and employees and other persons or entities performing portions of the Work for or on behalf of Contractor or any of its Subcontractors.

333 Contractor shall be responsible for inspection of portions of Work already performed, to determine which such portion are in proper condition to receive subsequent Work.

334 Contractor shall bear responsibility for design and execution of acceptable trenching and shoring procedures, in accordance with Texas Government Code, Section 2166.303 and Texas Health and Safety Code, Subchapter C, Sections 756.021, et seq.

335 It is understood and agreed the relationship of Contractor to City shall be of an independent contractor. Nothing contained or inferable in the Contract documents shall be read, deemed or construed to make Contractor the agent, servant or employee of City or create any partnership, joint venture or other association between City and Contractor. Any direction or instruction by City, in respect of the Work, shall relate to the results City desires to obtain from the Work and shall in no way affect Contractor's independent contractor status, as described herein.

336 Contractor shall review Subcontractor(s) written safety programs, procedures and precautions in connection with performance of the Work. However, Contractor's duties shall not relieve any Subcontractor(s) or any other person or entity (e.g. a supplier), including any person or entity with whom Contractor does not have a contractual relationship, of their responsibility or liability relative to compliance with all applicable federal, state and local laws, rules, regulations and ordinances, which shall include the obligation to provide for the safety of their employees, persons, and property and their requirements to maintain a work environment free of recognized hazards. The foregoing notwithstanding, the requirements of this **Section 3.3.6** are not intended to impose upon Contractor any additional obligations Contractor would not have under any applicable state or federal laws including, but not limited to, any rules, regulations or statutes pertaining to the Occupational Safety and Health Administration.

3.4 LABOR AND MATERIALS

341 Unless otherwise provided in the Contract Documents, Contractor shall provide and pay for all labor, materials, equipment, tools, construction equipment and machinery, water, heat, utilities, transportation and other facilities and services necessary for proper execution and completion of the Work, whether temporary or permanent and whether or not incorporated or to be incorporated in the Work.

342 **PREVAILING WAGE RATE AND LABOR STANDARD PROVISIONS.** The Provisions of Chapter 2258 of the Texas Government Code expressly are made a part of this Contract. In accordance therewith, a schedule of the general prevailing rate of per diem wages in this locality for each craft or type of worker needed to perform this Contract is part of the Contract Documents for all purposes. Contractor shall forfeit, as a penalty to City, sixty dollars (\$60.00) for each laborer, worker or mechanic employed for each calendar day, or portion thereof, in which such laborer, worker or mechanic is paid

less than the stipulated prevailing wage rates for any work done under this Contract by the Contractor or any Subcontractor employed on the project. The establishment of prevailing wage rates, pursuant to Chapter 2258 of the Texas Government Code, shall not be construed to relieve Contractor from its obligation under any federal or state law, regarding the wages to be paid to or hours worked by laborers, workers or mechanics, insofar as applicable to the work to be performed hereunder.

343

SUBSTITUTIONS

343.1 Contractor's proposed substitutions and alternates may be rejected by City without explanation and shall be considered by City only under one or more of the following conditions:

- (a) the proposal is required for compliance with interpretation of code requirements or insurance regulations then existing;
- (b) specified products are unavailable through no fault of Contractor; and
- (c) when in the judgment of City or Design Consultant, a substitution substantially would be in City's best interests in terms of cost, time or other considerations.

343.2 Contractor shall submit to City and Design Consultant:

- (a) a full explanation of the proposed substitution and submittal of all supporting data, including technical information, catalog cuts, warranties, test results, installation instructions, operating procedures and other like information necessary for a complete evaluation of the substitution;
- (b) a written explanation of the reasons the substitution is necessary, including the benefits to City and to the Work, in the event the substitution is acceptable to City;
- (c) the adjustment, if any, in the Contract Sum;
- (d) the adjustment, if any, in the Contract Time and the construction schedule; and
- (e) in the event of a substitution under **Section 3.4.3.1** herein, an affidavit stating:
 - (1) Contractor's proposed substitution conforms to and meets all the requirements of the pertinent Specifications and requirements shown on the Drawings; and
 - (2) Contractor accepts the warranty and correction obligations in connection with the proposed substitution as if originally specified by Design Consultant.

Proposals for substitutions shall be submitted to Design Consultant in sufficient time to allow Design Consultant no less than twenty-one (21) calendar days for review. No substitutions shall be considered or allowed without Contractor's submittal of complete substantiating data and information as stated hereinbefore.

343.3 In the event of a substitution submittal under this **Section 3.4.3**, and whether or not any such proposed substitution is accepted by City or Design Consultant, Contractor shall reimburse City, at City's reasonable discretion, for any fees incurred and charged by Design Consultant or other Consultants for evaluating each proposed substitute.

344

Contractor shall, at all times, enforce strict discipline and good order among persons working on the Project and shall not employ or continue to employ any unfit person on the Project or any person not skilled in the assigned work. Contractor shall be liable for and responsible to City for all acts and omissions of its employees, all tiers of its Subcontractors, material suppliers, anyone who Contractor may allow to perform any Work on the Project and their respective officers, agents, employees, and Consultants who Contractor may allow to come on the job site, with the exception of City or City's Designee. City, at any time, for any reason or for no reason, may direct Contractor to remove any

employee, Subcontractor, material supplier or anyone else from the Project and Contractor promptly shall comply with City's direction. In addition, if Contractor receives written notice from City complaining about any Subcontractor, employee or anyone who is a hindrance to the proper or timely execution of the Work, Contractor shall remedy such complaint without delay to the Project and at no additional cost to City. This provision shall be included in all contracts between Contractor and all Subcontractors of all tiers.

345 Contractor recognizes, accepts and hereby acknowledges the Project Site is a public facility representing the City of Pflugerville. As such, Contractor shall prohibit the possession or use of alcohol, controlled substances, tobacco and any prohibited weapons on the Project Site and shall require appropriate dress of Contractor's forces consistent with the nature of the Work being performed, including the wearing of shirts at all times. Harassment of any kind, including sexual harassment, of employees of Contractor or any Subcontractor, employees or Consultants of City or of any visitor to the Project site, by Contractor, employee(s) of Contractor, a Subcontractor or an employee of Subcontractor strictly is forbidden. Any person, Contractor, employee of Contractor, Subcontractor or employee of Subcontractor who is found to have engaged in such conduct shall be subject to appropriate disciplinary action by Contractor and/or City, including the removal and exclusion of the violating person(s) or employee(s) of Contractor or Subcontractor from the Project Site and, if City so elects, termination from the Project.

346 All materials and installed equipment shall be as specified in the Contract Documents and, if not so specified, shall be new and of good quality, except as otherwise provided in the Contract Documents. If required by City or Design Consultant, Contractor shall furnish satisfactory evidence (including reports of required tests) as to the source, kind and quality of materials and equipment installed. Contractor may make substitutions only with the consent of City, after Contractor's compliance with **Section 3.4.3** herein.

347 All materials shall be shipped, stored and handled in a manner which shall protect and ensure their condition at the time of incorporation in the Work. After installation, all materials shall be properly protected against damage to ensure they are in the condition as required by **Section 3.5.1** herein when the Work is Substantially Completed or City takes over use and occupancy, whichever is earlier. Materials not meeting Contract requirements or that do not produce satisfactory results shall be rejected by City, unless City or Design Consultant approves corrective actions. Upon rejection, Contractor immediately shall remove and replace rejected materials. If Contractor does not comply with these requirements, City may remove and replace defective material and all costs incurred by City for testing, removal and replacement of rejected materials shall be deducted from any money due or owed to Contractor.

The source of supply of each of the materials shall be approved by City or Design Consultant before delivery is started and, at the option of City, may be sampled and tested by City for determining compliance with the governing Specifications before delivery is started. If it is found after trial sources of supply previously approved do not produce uniform and satisfactory products, or if the product from any source proves unacceptable at any time, Contractor shall furnish materials from other approved sources. Only materials conforming to the requirements of the Contract documents and approved by City shall be used by Contractor in the work. All materials being used by Contractor are subject to inspection or test at any time during preparation or use. Any material which has been tested and accepted at the source of supply may be subjected to a check test after delivery and all materials which, when retested, do not meet the requirements of the Specifications shall be rejected. No material which, after approval, has in any way become unfit for use shall be used in the Work.

If, for any reason, Contractor selects a material which is approved for use by City or Design Consultant by sampling, testing or other means, and Contractor decides to change to a different material requiring

additional sampling and testing by City for approval, Contractor shall pay for any expense incurred by City for such additional sampling and testing and the costs incurred by City shall be deducted from any money due or owed to Contractor.

- 348 Contractor shall procure and furnish to City all guarantees, warranties, spares and maintenance manuals called for by the Specifications or which normally are provided by a manufacturer. The maintenance manual shall include a catalog for any equipment, materials, supplies or parts used in the inspection, calibration, maintenance or repair of the equipment and items in the catalog shall be readily available for purchase.
- 349 During construction of the Work and for four (4) years after final completion or longer if, during the duration of this Contract or during the four (4) years after the final completion of the Work, a dispute between any parties to this Project exists, Contractor shall retain and shall require all Subcontractors to retain for inspection and audit by City all books, accounts, reports, files, time cards, material invoices, payrolls and evidence of all other direct or indirect costs related to the bidding and performance of this Work. Upon request by City, a legible copy or the original of any or all such records shall be produced by Contractor at the administrative office of City. To the extent it requests copies of such documents, City shall reimburse Contractor and its Subcontractors for copying costs. Contractor shall not be required to keep records of or provide access to the makeup of any negotiated and agreed-to lump sums, unit prices or fixed overhead and profit multipliers.

3.5 WARRANTY

- 351 Contractor warrants and guarantees materials and equipment furnished and installed under the Contract shall be new and of good quality, unless otherwise required or permitted by the Contract Documents, the Work shall be free from defects not inherent in the quality required or permitted and the Work shall conform to the requirements of the Contract Documents. Contractor acknowledges and agrees that the Warranty Bond provided under **Section 11.3.1.1** herein shall include and ensure coverage for all warranty obligations contemplated by this **Section 3.5** and otherwise provided by the Contract Documents, but this coverage shall in no event be construed as the City's exclusive recourse in the event of Contractor's non-performance of its obligations provided herein. Work not conforming to this warranty and these requirements, including substitutions not properly approved and authorized by City, may be considered defective. Contractor's warranty excludes remedy for damage or defect caused by abuse, modifications not executed by the Contractor, improper or insufficient maintenance, improper operation, normal wear and tear and normal usage, and additional damage or defects caused by City's failure to promptly notify Contractor. If required by City, Contractor shall furnish satisfactory evidence as to the kind and quality of materials and equipment.
- 352 A right of action by City for any breach of Contractor's express warranty herein shall be in addition to, and not in lieu of, any other remedies City may have under this Contract at law or in equity, regarding any defective Work.
- 353 The warranty provided in **Section 3.5.1** herein shall be in addition to and not in limitation of any other warranty or remedy required by law or by the Contract Documents. Such warranty shall be interpreted to require Contractor, upon written demand by City as herein provided, to replace defective materials and equipment and re-execute any defective Work disclosed to the Contractor by City within a period of one (1) year after Substantial Completion, if applicable, or Final Completion of the applicable Work or, in the event of a latent defect, within one (1) year after discovery thereof by City.
- 354 All warranties shall be assignable by City. Submittal of all warranties and guarantees are required as a prerequisite to the final payment.

- 355 Except when a longer warranty time is specifically called for in the Specifications or is otherwise provided by law or by manufacturer, all warranties shall be at minimum for twelve (12) months and shall be in form and content otherwise reasonably satisfactory to City. City and Contractor acknowledge the Project may involve construction work on more than one (1) building or section of infrastructure of City's. While the overall Project shall have a single date for Substantial Completion of the Work and Final Completion of the Work, each building, section of infrastructure or approved phase of each section of infrastructure may have its own separate and independent date of Substantial Completion or Final Completion.
- 356 If separate dates for Substantial Completion and Final Completion are established and granted by City, at City's sole discretion and as a result of City electing partially to occupy areas prior to the Project's overall date for Substantial Completion, Contractor shall maintain a complete and accurate schedule of the dates of Substantial Completion and, if City accepts partial occupancy of those completed areas, the dates upon which the one (1) year warranty on each building, phase or section of infrastructure granted Substantial Completion shall expire. If separate dates are granted, Contractor agrees to provide notice of the warranty expiration date(s) to City and Design Consultant at least one (1) month prior to the expiration of the one (1) year warranty period on each building, section of infrastructure or each phase of the section of infrastructure which has achieved Substantial Completion.
- 357 Prior to termination of any one (1) year warranty period, Contractor shall, upon request of City, accompany City and Design Consultant on re-inspection of the building, section of infrastructure or phase of the section of infrastructure and be responsible for correcting any reasonable additional deficiencies not caused by City or by the use of the building, section of infrastructure or phase of the section of infrastructure observed and/or reported during the re-inspection.
- 358 For warranties required in this **Section 3.5** and otherwise provided by the Contract Documents, City shall notify Contractor of deficiencies and Contractor shall start remedying these defects within seven (7) calendar days of initial notification from City, unless a longer commencement date is agreed to by the City in writing for good cause shown. Following commencement, Contractor shall prosecute the work without interruption until accepted by City and Design Consultant, even though such prosecution may extend beyond the limit of the warranty period. In the event that Contractor should fail to so perform, City shall require Contractor's surety to perform under the Performance Bond provided in **Section 11.3.1.1** herein and/or take any other action available to the City at law or in equity to secure performance of Contractor's obligations under this **Section 3.5** and the Contract Documents. If Contractor fails to provide notice of the expiration of the one (1) year warranty period at least one (1) month prior to the expiration date and conduct the required walk through with City, Contractor's warranty obligations described in this **Section 3.5** shall continue until such inspection is conducted and any deficiencies found in the inspection is corrected.
- 359 Warranties shall become effective on a date established by City in accordance with the Contract Documents. This date shall be the date of Substantial Completion, if applicable, or Final Completion of the entire Work, unless otherwise provided in any Certificate of Partial Substantial Completion approved by the Parties, except for Work to be completed or corrected after the date of Substantial Completion and prior to final payment and those occurrences addressed in **Section 3.5.11** herein. Warranties for Work to be completed or corrected after the date of Substantial Completion and prior to Final Completion shall become effective on the later of the date the Work is completed or corrected and accepted by City and Design Consultant or the date of Final Completion of the Work.
- 3510 Neither final payment nor compliance by Contractor with any provision in the Contract Documents shall constitute an acceptance of Work not done in accordance with the Contract Documents or relieve Contractor or its sureties of liability, with respect to any warranties or responsibility for faulty materials and workmanship. Contractor warrants all Work shall conform to the requirements of the Contract

Documents.

- 3511 Contractor agrees to assign to City, at the time of Final Completion of the Work, any and all manufacturer's warranties relating to materials and labor used in the Work and further agrees to perform the Work in such manner so as to preserve any and all such manufacturer's warranties, provided such assignment shall contain a reservation of Contractor's right also to enforce the manufacturer's warranties. As a condition precedent to final payment, Contractor shall prepare a notebook with reference tabs and submit three (3) copies of the notebook to City which shall include a complete set of warranties from Subcontractors, manufacturers or suppliers, as appropriate, and executed by and between Contractor and City, as required under this Contract, with a specified warranty commencement date, as required by the Contract Documents. Copies of the complete set of warranties from Subcontractors, manufacturers and/or suppliers, as appropriate, executed by Contractor as required by the Contract Documents, with and between City and Contractor. A specified warranty commencement date, as required by the Contract Documents, also shall be submitted to City in an electronic format (PDF) on a USB flash drive.
- 3.6 **TAXES.** Contractor shall not include in the Contract Sum or any modification thereto any amount for sales, use or similar taxes for which City is exempt. Upon request by Contractor, City shall provide Contractor with a tax exemption certificate or other documentation necessary to establish City's exemption from such taxes.
- 3.7 PERMITS, FEES AND NOTICES**
- 371 **PERMITS.** Unless otherwise provided in the Contract Documents or by City, as per **Section 2.2.5** herein, it is the responsibility of and Contractor shall secure all permits, licenses and inspections. City and Design Consultant may assist Contractor, when necessary, in obtaining such permits, licenses and inspections necessary for the proper execution and completion of the work. If required for the Work, Contractor shall prepare and submit any paperwork, plans, notices, etc. necessary to comply with Texas Pollutant Discharge Elimination System (hereafter referred to as "TPDES") regulations of the Texas Commission on Environmental Quality as required by the Texas Water Code and the federal Clean Water Act.
- 372 Contractor shall comply with and give all notices required by law, ordinance, rule, regulations and lawful orders of public authorities applicable to performance of the Work.
- 373 It is not Contractor's responsibility to ascertain the Contract Documents are in accordance with applicable laws, statutes, ordinances, building codes and rules and regulations. However, if Contractor observes portions of the Contract Documents are at variance therewith, Contractor promptly shall notify City and Design Consultant in writing of any variances and all necessary changes shall be accomplished by appropriate modification(s) before Contractor performs any Work affected by such modification(s).
- 374 If Contractor performs Work knowing Work is contrary to laws, statutes, ordinances, building codes and rules and regulations, without such notice to and approval from City and Design Consultant, Contractor shall assume sole responsibility for performing such Work and shall bear all costs attributable to correct such Work.
- 375 Contractor also shall secure all permits and approvals and pay all fees and expenses, if any, associated with TPDES regulations of the Texas Commission on Environmental Quality, as well as those required by any federal regulations or local authorities, if applicable, which require completion of documentation and/or acquisition of a "Land Disturbing Activities Permit" for a Project. Contractor's obligations under this paragraph do not require it to perform engineering services during the pre-

construction phase to prepare proper drainage for the Project Site. However, any drainage alterations made by Contractor during the construction process, which require the issuance of a permit, shall be at Contractor's sole cost. It shall be Contractor's responsibility to prepare and submit the permit approval documentation provided by the regulatory agencies prior to beginning any Work.

3.8 ALLOWANCES

381 Contractor shall include in the Contract Sum all allowances stated in the Contract Documents. Items covered by allowances shall be supplied for such amounts and by such persons or entities as City may direct, but Contractor shall not be required to employ persons or entities to whom Contractor has reasonable objection.

382 Unless otherwise provided in the Contract Documents:

3.8.2.1 Allowances shall cover the cost to Contractor of materials and equipment delivered at the site and all required taxes, less applicable trade discounts;

3.8.2.2 Contractor's costs for unloading and handling at the site, labor, installation costs, overhead, profit and other expenses, contemplated for stated allowance, shall be included in the allowances;

3.8.2.3 Whenever actual costs are more than or less than allowances, the Contract Sum shall be adjusted accordingly by Change Order and in accordance with **Article VII** herein. The amount of the Change Order shall reflect both the difference between actual costs and the allowances under **Section 3.8.2.1** herein and all changes in Contractor's costs under **Section 3.8.2.2** herein.

383 Materials and equipment under an allowance shall be selected by City within such time as is reasonably specified by Contractor as necessary to avoid any delay in the Work.

3.9 SUPERINTENDENT/KEY PERSONNEL

391 At all times during the progress of the Work, Contractor shall assign a competent resident superintendent who is able to communicate fluently in English, along with any necessary assistant(s) who is/are satisfactory to City. Any superintendent designee shall be identified in writing to City promptly after City issues written Notice to Proceed. The superintendent shall represent Contractor at all times and all directions given to the superintendent shall be binding on Contractor. The designated superintendent shall not be replaced without written notice to and the approval of City, which approval shall not be unreasonably withheld, except with good reason (including any termination or disability of the superintendent) or under extraordinary circumstances. The superintendent may not be employed on any other project prior to Final Completion of the Work without the approval of City, which approval shall not be unreasonably withheld.

392 Contractor shall furnish an updated list to Design Consultant and City of all Architects, Engineers, Consultants, Sub-Consultants, job-site superintendents, Subcontractors and suppliers involved in the Project construction indicated in Contractor's submitted Bid Proposal.

392.1 City, upon the showing of good and reasonable cause, may reject or require removal of any Architect, Engineer, Consultant, Sub-Consultant, job superintendent, employee of the Contractor, Subcontractor or sub- Subcontractor and/or supplier involved in the Project.

392.2 Contractor shall provide an adequate staff for the proper coordination and expedition of the Work. City reserves the right to require Contractor to remove from the Project any

employee(s) City, at its sole discretion, deems incompetent, careless, insubordinate, unnecessary or in violation of any provision in these Contract Documents. This provision is applicable to Subcontractors, sub-Subcontractors and their employees.

3.923 City reserves the right to utilize one or more of its employees or Consultants to function in the capacity of City's Inspector or COI, whose primary function shall be daily inspections, checking pay requests or construction timelines and the verification of the storage of supplies and materials.

3.924 Contractor shall not change any key personnel or key Subcontractors without the prior written consent of City, which consent shall not be unreasonably withheld. In the event key personnel leaves Contractor's employment, such key personnel's replacement shall be subject to City's reasonable approval.

3.10 CONTRACTOR'S PROJECT SCHEDULES

3.101 **PROJECT SCHEDULE METHOD.** Contractor shall create and maintain a Critical Path Method (hereafter referred to as "CPM") Project Schedule, showing the manner of execution of Work which Contractor intends to follow, in order to complete the Project within the allotted time. The Project Schedule shall employ computerized CPM for the planning, scheduling and reporting of Work, as described in this **Section 3.10**. Contractor shall create and maintain the Project Schedule using project management scheduling software compatible with City's project management scheduling software, if any. The observance of the requirements herein is an essential part of the Work to be performed under the Contract.

3.102 **SCHEDULING PERSONNEL.** Unless otherwise indicated in writing by City, Contractor shall create and maintain the Project Schedule. Contractor's Scheduler shall be proficient in CPM analysis, possess sufficient experience to be able to perform required tasks on the specified software and able to prepare and interpret reports from the software. Scheduler shall be made available for discussion or meetings when requested by City.

3.103 PROJECT SCHEDULE SUBMISSION

3.103.1 Unless indicated otherwise, Contractor shall submit Project Schedule(s) for the Work in relation to the entire Project to City and Design Consultant at least fifteen (15) calendar days prior to the pre-construction conference.

3.103.2 All Project Schedule submittals shall be in electronic form to include PDF plots of the schedule, a PDF plot defining the Critical Path and two week look-ahead, and include the native compatible scheduling file format. Contractor shall submit the schedule to City and Design Consultant via electronic mail, CD-Rom or any other electronic format acceptable to City.

3.103.3 This initial Project Schedule shall indicate the dates for starting and completing the various aspects/phases required to complete the Work, including mobilization, procurement, installation, testing, inspection and acceptance of all the Work of the Contract, including any contractually mandated Milestone dates. The Project Schedule shall not exceed the time limits set forth in the Contract Documents. Contractor shall organize the Project Schedule and provide adequate detail so the Schedule is capable of measuring and forecasting the effect of delaying events on completed and uncompleted activities.

3.103.4 The Project Schedule shall show the order in which Contractor proposes to carry

out the Work in accordance with the final approved phasing plan, if any, and the anticipated start and completion dates of each phase of the Work. The Project Schedule shall be in the form of a time scaled work progress chart, to indicate the percentage of Work scheduled for completion at various critical Milestones.

3.103.5 Contractor shall maintain a schedule of Shop Drawings and Sample Submittals and each submitted Shop Drawing and Sample Submittal shall list each required submittal and the expected time(s) for submitting, reviewing and processing such submittal.

3.103.6 City shall review the Project Schedule within fifteen (15) calendar days for compliance with the Specifications and notify Contractor of its acceptability.

3.104 **PROJECT SCHEDULE SEQUENCING.** The Project Schedule shall show the sequence and interdependence of activities required for complete performance of the Work. Contractor shall be responsible for assuring all Work sequences are logical and show a coordinated plan of Work in accordance with the sequence of work outlined in the Plans. The purpose of City requiring the Project Schedule shall be to:

3.104.1 Ensure adequate planning during the execution and progress of the Work in accordance with the allowable number of calendar days and all Milestones;

3.104.2 Assure coordination of the efforts of Contractor, City, utilities and others that may be involved in the Project and those activities are included in the Schedule highlighting coordination points with others;

3.104.3 Assist Contractor and City in monitoring the progress of the Work and evaluating proposed changes to the Contract; and

3.104.4 Assist City in administering the Contract Time requirements.

3.105 **PROJECT SCHEDULE ACTIVITIES.** Contractor shall provide City a legend for all abbreviations used. The activities shall be coded so organized plots of the Project Schedule may be produced. Typical activity coding includes traffic control phase, location and work type. Contractor shall show an estimated production rate per working day for each Work activity. Activity durations shall be based on production rates shown. Each activity on the Project Schedule shall include:

3.105.1 An activity number utilizing an alphanumeric designation system agreeable to City;

3.105.2 A concise description of the Work represented by the activity; and

3.105.3 Activity durations in whole work days, with a maximum of twenty (20) work days. Durations greater than twenty (20) work days may be used for non-construction activities (mobilization, submittal preparation, curing, etc.), and other activities mutually agreeable between City and Contractor.

3.106 **PROJECT SCHEDULE WORK DURATION AND RESOURCES**

3.106.1 The Project Schedule layout shall be grouped by Project and then by Work Breakdown Structure (hereafter referred to as "WBS") for organizational purposes.

- 3.10.62 The original and remaining Work duration shall be displayed. The grouping band shall, by default, report Work days planned. One additional level of effort activity shall be added to the schedule as a “time calculator” with a seven (7) day calendar without holidays reflected. The calculation of days should be reflected in the appropriate duration columns.
- 3.10.63 Contractor shall update working day calendars originally created by City and included as part of the Bid Solicitation for the days Contractor plans to work. Contractor shall designate all City holidays as non-working days (holidays). For dates beyond the then-current calendar year, Contractor shall assume City holidays are the same as the current calendar year.
- 3.10.64 Seasonal weather conditions shall be considered and included in the Project Schedule for all work influenced by temperature and/or precipitation. Seasonal weather conditions shall be determined by an assessment of average historical climatic conditions. Average historical weather data is available through the National Oceanic and Atmospheric Administration (hereafter referred to as “NOAA”). These effects shall be simulated through the use of work calendars for each major work type (i.e., earthwork, concrete paving, structures, asphalt, drainage, etc.). Project and work calendars should be updated each month to show days actually able to work on the various work activities.
- 3.10.65 Only City-responsible delays in activities affecting Milestone dates or the Contract completion date(s), or unusually severe weather as determined under **Section 4.3.6** herein, as determined by CPM analysis, shall be considered for a Contract Time extension.

3.10.7 PROJECT SCHEDULE - OTHER REQUIREMENTS. The Project Schedule shall:

- 3.10.7.1 have all Work coded and organized by WBS. An example of an acceptable WBS shall be provided, upon written request, by City to Contractor;
- 3.10.7.2 reflect Duration Percent complete as the percent complete type;
- 3.10.7.3 reflect Fixed Units as the duration type;
- 3.10.7.4 include submittals with a logical tie to what each drives;
- 3.10.7.5 add proposed Change Order(s) and those Change Order(s) shall be reflected on the Schedule as proposed Change Order(s). This task shall be linked to the schedule with logical ties and approved by City. Upon approval of a Change Order, a task shall be renamed and shall identify Work performed and Change Order number and resources shall be added to the task;
- 3.10.7.6 only have constraints in accordance with the Plans;
- 3.10.7.7 include activity dates for material delivery;
- 3.10.7.8 disallow default progress; and
- 3.10.7.9 include a detailed explanation in the Project narrative, if Work is performed out of sequence.

3.10.8 PROJECT SCHEDULE JOINT REVIEW AND ACCEPTANCE

- 3.10.81 The Project Schedule and successive updates or revisions thereof are for Contractor's use in managing the Work. The Project Schedule is for the information of City and to demonstrate Contractor has complied with requirements for planning the Work.
- 3.10.82 Within fifteen (15) calendar days of receipt of Contractor's proposed Project Schedule, City shall evaluate the Schedule for compliance with this specification and notify Contractor of its findings. If City requests a revision or justification, Contractor shall provide satisfaction to City within seven (7) calendar days. If Contractor submits a Project Schedule for acceptance, based on a sequence of work not shown in the Plans, Contractor shall notify City in writing of said sequence of work, separate from the Schedule submittal.
- 3.10.83 City's review and acceptance of Contractor's Project Schedule is solely for conformance to the requirements of the Contract Documents. Review and acceptance by City of Contractor's Project Schedule does not relieve Contractor of any of its responsibility for the Project Schedule, Contractor's ability to meet interim Milestone dates (if so specified) or meeting the Contract completion date, nor does such review and acceptance expressly or by implication warrant, acknowledge or admit the reasonableness of the logic, durations, manpower or equipment loading of Contractor's Project Schedule. In the event Contractor fails to define any element of Work, activity or logic and City's review does not detect this omission or error, such omission or error, whether or when discovered by Contractor or City, shall be corrected by Contractor at the next monthly schedule update and shall not affect the Project or Contract completion date.
- 3.10.84 Acceptance of the Project Schedule, or update and/or revision thereto, does not indicate any approval of Contractor's proposed sequences and duration.
- 3.10.85 Acceptance by City of the Project Schedule or updated Project Schedule which exceeds contractual time does not alleviate the Contractor's obligation to meet the contractual completion date.
- 3.10.86 Acceptance of a Project Schedule update or revision indicating early or late completion does not constitute City's consent to any changes, alter the terms of the Contract, waive either Contractor's responsibility for timely completion, or waive City's right to damages for Contractor's failure to do so.
- 3.10.87 Contractor's scheduled dates for completion of any activity or of the entire Work do not constitute a change in terms of the Contract. Change Orders are the only method of modifying the completion date(s) and Contract time.
- 3.10.88 Submittal of a schedule, schedule revision or schedule update constitutes Contractor's representation to City, as of the date of the submittal, of the accurate depiction of all progress to date and Contractor shall follow the schedule as submitted in performing the Work.

3.10.9 PROJECT SCHEDULE UPDATES AND REVISIONS

- 3.10.9.1 The Project Schedule shall be updated monthly, at a minimum, to reflect progress to date and current plans for completing the Work. An electronic copy of the update shall be submitted to City and Design Consultant as directed. City has no duty to make progress payments to Contractor unless Contractor's payment application is accompanied by the updated Project Schedule. The anticipated date of Substantial Completion shall show all extensions of time granted through Change Order(s) as of the date of the update.

- 3.1092 The Project Schedule update shall be submitted no later than the date the pay application is submitted.
- 3.1093 Contractor shall meet with City each month, at a scheduled Project Schedule update meeting, to review actual progress made through the date of the schedule update, as determined by City. Contractor shall bring one record copy of the Drawings marked up to reflect current progress for City inspection. The review of progress shall include dates of activities actually started and/or completed, the percentage of Work completed, the remaining duration of each activity started and/or completed and the amount of Work still to complete, with an analysis of the relationship between the remaining duration of the activity and the quantity of material to install over that given period of time with a citation of past productivity.
- 3.1094 The monthly Schedule Update shall include a progress narrative, explaining the Project's progress, identifying all progress made out of sequence, defining the Critical Path, identification of any potential delays, and other relevant data. A Project Schedule Narrative template shall be required for the narrative. Upon request, City shall supply said template to Contractor.
- 3.1095 Each Schedule shall segregate the Work into a sufficient number of activities to facilitate the efficient use of critical path method scheduling by Contractor, City and Design Consultant. The Project Schedule layout shall be grouped first by Project then by WBS. The layout shall include the following columns:
- (1) Activity ID
 - (2) Activity Description
 - (3) Original Durations
 - (4) Remaining Durations
 - (5) Early Start and Early Finish Dates
 - (6) Late Start and Late Finish Dates
 - (7) Total Float
 - (8) Performance Percent Complete
 - (9) Display logic and target bars in the Gantt bar chart view
- 3.1096 Each schedule shall include activities representing manufacturing, fabrication or ordering lead time for materials, equipment or other items for which Design Consultant is required to review submittals, shop drawings, product data or samples.
- 3.1097 Each schedule, other than the initial Project Schedule, shall:
- (1) indicate the activities, or portions thereof, which have been completed;
 - (2) reflect the actual time for completion of such activities; and
 - (3) reflect any changes to the sequence or planned duration of all activities.
- 3.1098 If any updated schedule exceeds the time limits set forth in the Contract Documents for Substantial Completion or Final Completion of the Work, Contractor shall include, along with its updated schedule, a statement of the reasons for the anticipated delay in achieving Substantial Completion of the Work and Contractor's planned course of action for completing the Work within the time limits set forth in the Contract Documents. If Contractor asserts the failure of City or Design Consultant to provide requested and required information to

Contractor as the reason for anticipated delay in completion, Contractor also shall specify what information has been requested and is required from City or Design Consultant.

3.109.9 Neither City nor Contractor shall have exclusive ownership of float time in the schedule and all float time shall inure to the benefit of the Project.

3.109.10 Submission of any schedule under this Contract constitutes a representation by Contractor, as of the date of the submittal:

- (1) the schedule represents the sequence in which Contractor intends to prosecute the remaining Work;
- (2) the schedule represents the actual sequence and duration used to prosecute the completed Work;
- (3) to the best of its knowledge and belief, Contractor is able to complete the remaining Work in the sequence and time indicated; and
- (4) Contractor intends to complete the remaining work in the sequence and time indicated.

3.109.11 If Contractor desires to make major changes in the Project Schedule, Contractor shall notify City in writing and submit the proposed schedule revision. The written notification shall include the reason for the proposed revision, what the revision is composed of and how the revision was incorporated into the schedule. Major changes are hereby defined as those affecting compliance with the Contract requirements and/or those that change the Project's critical path. All other changes may be accomplished through the monthly updating process without written notification. Refer to 3.10.8.7 for major changes that affect Contract completion dates and Contract Time.

3.10.10 COMPLETION OF WORK

3.10.10.1 Contractor is accountable for Substantially Completing and Finally Completing the Work in the Contract Time or as otherwise amended by Change Order.

3.10.10.2 If, in the sole judgment of City, the Schedule update reflects Work is behind schedule and the rate of performance of Work is inadequate to regain scheduled progress to insure Contractor achieving any Project Milestones (including, but not limited to, Substantial and/or Final Completion) in accordance with the Project Schedule, City may, at its sole option, give written notice to Contractor and direct Contractor, at Contractor's sole expense, to propose and adopt a plan to accelerate the Work so the Work conforms to the Project Schedule and Project Milestones previously agreed upon. Contractor may, but is not limited to, propose:

- (1) increasing Project work forces;
- (2) increasing Project equipment or tools;
- (3) increasing the hours of work or number of shifts per day;
- (4) expediting the delivery of Project materials;
- (5) changing, with the approval of City, the schedule logic and Work sequences; or
- (6) taking some other action as Contractor may proposes, if acceptable to City.

3.10.10.3 Within ten (10) calendar days after such notice from City, Contractor shall notify City in writing of the specific measures taken and/or planned to be taken to increase the rate of progress of Work on the Project. Contractor shall include an estimate as to the date of scheduled full progress recovery and an updated Project Schedule, illustrating Contractor's plan for achieving timely completion of the Project Milestone's and the Project's Substantial and/or Final Completion.

3.10.104 Should City deem Contractor’s plan of action inadequate to achieve the desired acceleration to bring the Work back on the Project Schedule and achieve Substantial Completion on time, City shall have the right to order Contractor, at Contractor’s sole expense, to take any corrective measures City deems necessary to expedite the progress of Work including, without limitations:

- (1) increasing work forces and hours, to include Contractor working additional shifts of overtime;
- (2) supplying additional manpower, equipment and facilities;
- (3) re-sequencing the Work;
- (4) expediting the fabrication and supply of materials; and/or
- (5) other similar measures City may direct (hereafter (1) – (5) herein above collectively referred to as “Extraordinary Measures”).

Such Extraordinary Measures City directs shall continue until the progress of the Work complies with the Milestone required by the Contract Documents and any additional expense, including additional expense incurred by the City, shall be borne solely by the Contractor, except as authorized by **Section 4.3.11** herein.

3.10.105 City’s right to require Extraordinary Measures solely is for the purpose of ensuring Project Milestones and Substantial and/or Final Completion of the Work is achieved within the Contract Time. Contractor shall not be entitled to an adjustment in the Contract Sum in connection with Extraordinary Measures required by City under or pursuant to this **Section 3.10**, except as may be provided under the provisions of **Section 4.3.11** herein.

3.10.106 City may exercise the rights furnished pursuant to this **Section 3.10** as frequently as City deems necessary to ensure Contractor’s performance of the Work is in compliance with any Milestone date or completion date(s) set forth in the Contract Documents.

3.10.107 Contractor shall recommend to City and Design Consultant a schedule for procurement of long-lead time items, which shall constitute part of the Work as required to meet the Project Schedule.

3.10.11 PROJECT SCHEDULE TIME IMPACT ANALYSIS

Contractor shall notify City when an impact may justify an extension of Contract Time or adjustment of Milestone dates. Said notice shall be made by Contractor in writing as soon as possible, but no later than the end of the next estimate period after the commencement of an impact or the notice for a change is given to Contractor. Not providing notice to City within twenty (20) calendar days after receipt shall indicate Contractor’s approval of the time charges as shown on that time statement. Future consideration of that statement shall not be permitted, and Contractor forfeits its right to subsequently request a time extension or time suspension.

3.10.11.1 When changes are initiated, or impacts are experienced, Contractor shall submit to City a written Time Impact Analysis describing the influence of each change or impact. A “Time Impact Analysis” is an evaluation of the effects of changes in the construction sequence, contract, Plans or site conditions on Contractor's plan for constructing the Project, as represented by the Project Schedule. The purpose of the Time Impact Analysis is to determine if the overall Project has been delayed and, if necessary, to provide Contractor and City a basis for making adjustments to the Contract.

3.10.11.2 A Time Impact Analysis shall consist of one or all of the steps listed below:

- (1) Establish the status of the Project before the impact using the most recent Project Schedule Update prior to the impact occurrence.
- (2) Predict the effect of the impact on the most recent Project Schedule Update prior to the impact occurrence. This requires estimating the duration of the impact and inserting the impact into the schedule update. Any other changes made to the schedule including modifications to the calendars or constraints shall be noted.
- (3) Track the effects of the impact on the schedule during its occurrence. Note any changes in sequencing and mitigation efforts.
- (4) Compare the status of the work prior to the impact (**#1 above**) to the prediction of the effect of the impact (**#2 above**), and to the status of the work during and after the effects of the impact are over (**#3 above**). Note: if an impact causes a lack of access to a portion of the Project, the effects of the impact may extend to include a reasonable period for remobilization.

3.10.11.3 The Time Impact Analysis shall be electronically submitted to City. If the Project Schedule is revised after the submittal of a Time Impact Analysis but prior to its approval, Contractor promptly shall indicate in writing to City the need for any modification to its Time Impact Analysis. One (1) copy of each Time Impact Analysis shall be submitted within fourteen (14) calendar days after the completion of an impact. City may require **Step 1** and **Step 2** in **Section 3.10.11.2** herein of the Time Impact Analysis be submitted at the commencement of the impact, if needed to make a decision regarding the suspension of Contract Time. Approval or rejection of each Time Impact Analysis by City shall be made within fourteen (14) calendar days after receipt, unless subsequent meetings and negotiations are necessary.

3.11 DOCUMENTS AND SAMPLES AT THE SITE

- 3.11.1 Contractor shall maintain, on Site and for City's use, one record copy of the Drawings, Specifications, Addenda, Change Orders and other Amendments, in good order and currently marked, to record field changes and selections made during construction, along with one record copy of approved Shop Drawings, Product Data, Samples and similar required submittals. These record copies also shall be available to Design Consultant and shall be delivered to Design Consultant for submittal to City upon completion of the Work.
- 3.11.2 Contractor shall at all times maintain job records including, but not limited to, invoices, payment records, payroll records, daily reports, logs, diaries and job meeting minutes applicable to the Project. Contractor shall make such reports and records available for inspection by City, Design Consultant and/or their respective agents, during normal business hours if requested by City.

3.12 SHOP DRAWINGS, PRODUCT DATA AND SAMPLES

- 3.12.1 Shop Drawings are drawings, diagrams, illustrations, schedules, performance charts, brochures and other data prepared and furnished by Contractor or its agents, manufacturers, suppliers or distributors and which illustrate and detail some portion of the Work.
- 3.12.2 Product Data are illustrations, standard schedules, performance charts, instructions, brochures, diagrams and other information furnished by Contractor to illustrate materials or equipment for some portion of the Work.
- 3.12.3 Samples are physical samples of materials, equipment or workmanship representative of some portion of

the Work, furnished by the Contractor to City, to assist City and Design Consultant in the establishment of workmanship and quality standards by which the Work shall be judged.

- 3.124 Shop Drawings, Product Data, Samples and similar submittals are not Contract Documents. The purpose of their submittals is to demonstrate, for those portions of the Work for which submittals are required by the Contract Documents, the way by which Contractor proposes to conform to the information given and the design concept expressed in the Contract Documents. Review by Design Consultant is subject to the limitations of **Section 4.2.6** herein. Informational submittals, upon which Design Consultant is not expected to take responsive action, may be so identified in the Contract Documents. Submittals which are not required by the Contract Documents may be returned by the Design Consultant without action.
- 3.125 Contractor shall review for compliance with the Contract Documents, approve and submit to Design Consultant Shop Drawings, Product Data, Samples and similar submittals required by the Contract Documents with reasonable promptness and in such sequence as to cause no delay in the Work or in the activities of City or of separate contractors. Submittals which are not marked as reviewed for compliance with the Contract Documents and approved by Contractor may be returned by Design Consultant without action.
- 3.126 By approving and submitting Shop Drawings, Product Data, Samples and similar submittals, Contractor represents it has determined and verified materials, field measurements and filed construction criteria related thereto, or shall do so, and has checked and coordinated the information contained within such submittals with the requirements of the Work and of the Contract Documents.
- 3.127 Contractor shall perform no portion of the Work for which the Contract Documents require submittal and review of Shop Drawings, Product Data, Samples or similar submittals until the respective submittal and review has been approved by Design Consultant. Design Consultant shall review and return such submittals within ten (10) calendar days or within a reasonable period so as to not delay the project.
- 3.128 The Work shall be in accordance with approved submittals, except Contractor shall not be relieved of responsibility for deviations from requirements of the Contract Documents by Design Consultant's approval of Shop Drawings, Product Data, Samples or similar submittals unless Contractor specifically has informed Design Consultant in writing of such deviation at the time of submittal and:
- (1) Design Consultant has given written approval in the specific deviation as a minor change in the Work; or
 - (2) a Change Order or Field Work Directive has been issued authorizing the deviation. Contractor shall not be relieved of responsibility for errors or omissions in Shop Drawings, Product Data, Samples or similar submittals by Design Consultant's approval thereof.
- 3.129 Contractor shall direct specific attention, in writing or on resubmitted Shop Drawings, Product Data, Samples or similar submittals, to revisions other than those requested by Design Consultant on previous submittals. In the absence of such written notice, Design Consultant's approval of a resubmission shall not apply to such revisions.
- 3.1210 Contractor shall not be required to provide professional services which constitute the practice of architecture or engineering unless such services specifically are required by the Contract Documents for a portion of the Work or unless Contractor needs to provide such services in order to carry out Contractor's responsibilities for construction means, methods, techniques, sequences and procedures. Contractor shall not be required to provide professional services in violation of applicable law. If

professional design services or certifications by a design professional related to systems, materials or equipment specifically are required of Contractor by the Contract Documents, City and Design Consultant shall specify all performance and design criteria such services must satisfy. Contractor shall cause such services or certifications to be provided by a properly Texas-licensed design professional, whose signature and seal shall appear on all drawings, calculations, Specifications, certifications, Shop Drawings and other submittals prepared by such professional. Shop Drawings and other submittals related to the Work designed or certified by such professional, if prepared by others, shall bear such professional's written approval when submitted to Design Consultant. City and Design Consultant shall be entitled to rely upon the adequacy, accuracy and completeness of the services, certifications or approvals performed by such design professionals, provided City and Design Consultant have specified to Contractor all performance and design criteria such identified services must satisfy. Pursuant to this **Section 3.12.10**, Design Consultant shall review, approve or take other appropriate action on submittals only for the limited purpose of checking of conformance with information given and the design concept expressed in the Contract Documents. Contractor shall not be responsible for the adequacy of the performance or design criteria required by the Contract Documents.

3.13 **ACCESS TO WORK.** Contractor shall provide City and Design Consultant access to Work in preparation and in progress, wherever located.

3.14 **PATENT FEES AND ROYALTIES.** Contractor shall pay all license fees and royalties and assume all costs incident to the use of the performance of the Work or the incorporation in the Work of any invention, design, process, product or device which is the subject of patent rights or copyrights held by others. If a particular invention, design, process, product or device is specified in the Contract Documents for use in the performance of the Work and if to the actual knowledge of City its use is subject to patent rights or copyrights calling for the payment of any license fee or royalty to others, the existence of such rights shall be disclosed by City in the Contract Documents.

3.15 INDEMNITY PROVISIONS

3.15.1 **CONTRACTOR COVENANTS AND AGREES TO FULLY INDEMNIFY, DEFEND AND HOLD HARMLESS, CITY AND ITS ELECTED OFFICIALS, EMPLOYEES, OFFICERS, DIRECTORS, VOLUNTEERS AND REPRESENTATIVES OF CITY, INDIVIDUALLY AND COLLECTIVELY, FROM AND AGAINST ANY AND ALL COSTS, CLAIMS (INCLUDING THIRD-PARTY CLAIMS), LIENS, DAMAGES, LOSSES, EXPENSES, FEES, FINES, PENALTIES, PROCEEDINGS, ACTIONS, DEMANDS, CAUSES OF ACTION, LIABILITY AND SUITS OF ANY KIND AND NATURE, INCLUDING BUT NOT LIMITED TO, PERSONAL OR BODILY INJURY, DEATH AND PROPERTY DAMAGE, MADE UPON CITY DIRECTLY OR INDIRECTLY ARISING OUT OF, RESULTING FROM OR RELATED TO CONTRACTOR'S ACTIVITIES UNDER THIS CONTRACT, INCLUDING ANY ACTS OR OMISSIONS OF CONTRACTOR, ANY AGENT, OFFICER, DIRECTOR, REPRESENTATIVE, EMPLOYEE, CONSULTANT OR SUBCONTRACTOR OF CONTRACTOR AND CONTRACTOR'S AND ITS SUBCONTRACTOR'S RESPECTIVE OFFICERS, AGENTS EMPLOYEES, DIRECTORS AND REPRESENTATIVES WHILE IN THE EXERCISE OF THE RIGHTS OR PERFORMANCE OF THE DUTIES UNDER THIS CONTRACT. THE INDEMNITY PROVIDED FOR IN THIS PARAGRAPH SHALL NOT APPLY TO ANY LIABILITY RESULTING FROM THE NEGLIGENCE OF CITY, ITS OFFICERS OR ITS EMPLOYEES IN INSTANCES WHERE SUCH NEGLIGENCE CAUSES PERSONAL INJURY, DEATH, OR PROPERTY DAMAGE. IN THE EVENT CONTRACTOR AND CITY ARE FOUND JOINTLY LIABLE BY A COURT OF COMPETENT JURISDICTION, LIABILITY SHALL BE APPORTIONED COMPARATIVELY IN ACCORDANCE WITH THE LAWS FOR THE STATE OF TEXAS, WITHOUT, HOWEVER, WAIVING ANY GOVERNMENTAL IMMUNITY AVAILABLE TO CITY UNDER TEXAS**

LAW AND WITHOUT WAIVING ANY DEFENSES OF THE PARTIES UNDER TEXAS LAW.

- 3.152 The provisions of this Indemnity solely are for the benefit of the Parties hereto and not intended to create or grant any rights, contractual or otherwise, to any other person or entity. Contractor shall advise City in writing within twenty-four (24) hours of any claim or demand against City or Contractor known to Contractor related to or arising out of Contractor's activities under this Contract and shall see to the investigation and defense of such claim or demand at Contractor's sole cost. City shall have the right, at its option and at its own expense, to participate in such defense without relieving Contractor of any of its obligations under this **Section 3.15**.
- 3.153 **INTELLECTUAL PROPERTY INDEMNIFICATION. CONTRACTOR SHALL PROTECT, INDEMNIFY, AND DEFEND AND/OR HANDLE AT ITS OWN COST AND EXPENSE ANY CLAIM OR ACTION AGAINST CITY, ITS ELECTED OFFICIALS, EMPLOYEES, OFFICERS, DIRECTORS, VOLUNTEERS AND REPRESENTATIVES OF CITY, INDIVIDUALLY OR COLLECTIVELY, FOR INFRINGEMENT OF ANY UNITED STATES PATENT, COPYRIGHT OR SIMILAR PROPERTY RIGHT INCLUDING, BUT NOT LIMITED TO, MISAPPROPRIATION OF TRADE SECRETS AND ANY INFRINGEMENT BY CONTRACTOR AND ITS EMPLOYEE OR ITS SUBCONTRACTORS AND THEIR AGENTS, SERVANTS AND EMPLOYEES, BASED ON ANY DELIVERABLE OR ANY OTHER MATERIALS FURNISHED HEREUNDER BY CONTRACTOR AND USED BY EITHER CITY OR CONTRACTOR WITHIN THE SCOPE OF THIS CONTRACT (UNLESS SAID INFRINGEMENT RESULTS DIRECTLY FROM CONTRACTOR'S COMPLIANCE WITH CITY'S WRITTEN STANDARDS OR SPECIFICATIONS).** Contractor does not warrant against infringement by reason of City's or Design Consultant's design of articles or their use in combination with other materials or in the operation of any process. Contractor shall have the sole right to conduct the defense of any such claim or action and all negotiations for its settlement or compromise, unless otherwise mutually agreed upon, expressed in writing and signed by the Parties hereto. Contractor agrees to consult with City's City Attorney during such defense or negotiations and make good faith efforts to avoid any position adverse to the interest of City. City shall make available to Contractor any deliverables and/or works made for hire by Contractor necessary to the defense of Contractor against any claim of infringement for the duration of Contractor's legal defense.
- 3.154 If such infringement claim or action has occurred or, in Contractor's judgment, is likely to occur, City shall allow Contractor, at Contractor's option and expense, (unless such infringement results directly from Contractor's compliance with City's written standards or Specifications or by reason of City's or Design Consultants' design of articles or their use in combination with other materials or in the operation of any process for which City shall be liable) to elect to:
- (1) procure for City the right to continue using said deliverable and/or materials;
 - (2) modify such deliverable and/or materials to become non-infringing (provided such modification does not adversely affect City's intended use of the deliverable and/or materials as contemplated hereunder);
 - (3) replace said deliverable and/or materials with an equally suitable, compatible and functionally equivalent non-infringing deliverable and/or materials at no additional charge to City; or
 - (4) if none of the foregoing alternatives is reasonably available to Contractor, upon written request, City shall return the deliverable and/or materials in question to Contractor and Contractor shall refund all monies paid by City, with respect to such deliverable and/or materials, and accept return of same. If any such cure provided for in this **Section 3.15** shall fail to satisfy the third-party claimant, these actions shall not relieve Contractor from

its defense and indemnity obligations set forth in this **Section 3.15**.

- 3.155 The Indemnification obligations under this **Section 3.15** shall not be limited in any way by the limits of any insurance coverage or any limitation on the amount or type of damages, compensation or benefits payable by, for or to Contractor or any Subcontractor, supplier or any other individual or entity under any insurance policy, workers' compensation acts, disability benefit acts or other employee benefits acts.
- 3.156 **WORKER SAFETY.** The Indemnification hereunder shall include, without limiting the generality of the foregoing, liability which could arise to City, its agents, Consultants and/or representatives or Design Consultant pursuant to State statutes for the safety of workers and, in addition, all Federal statutes and rules existing there under for protection, occupational safety and health to workers. It is agreed the primary obligation of Contractor is to comply with these statutes in the performance by Contractor of the Work and the obligations of City, its agents, Consultants and representatives under said statutes are secondary to that of Contractor.
- 3.157 **DEFENSE COUNSEL.** City shall have the right to approve defense counsel, of which approval shall not be unreasonably withheld, to be retained by Contractor in fulfilling its obligation hereunder to defend and indemnify City, unless such right is expressly waived by City in writing. Contractor shall retain City- approved defense counsel within ten (10) calendar days of City's written notice City is invoking its right to Indemnification under this Contract. If Contractor fails to retain counsel within such time period, City shall have the right to retain defense counsel on its own behalf and Contractor shall be liable for all costs incurred by City. City also shall have the right, at its option, to be represented by advisory counsel of its own selection and at its own expense, without waiving the foregoing.
- 3.16 **REPRESENTATIONS AND WARRANTIES.** Contractor represents and warrants the following to City (in addition to the other representations and warranties contained in the Contract Documents), as an inducement to City to execute this Contract, which representations and warranties shall survive the execution and delivery of the Contract and the Final Completion of the Work, Contractor:
- 3.161 is financially solvent, able to pay its debts as they mature and possessed of sufficient working capital to complete the Work and perform its obligations under the Contract Documents;
- 3.162 is able to furnish the plant, tools, materials, supplies, equipment and labor required to complete the Work and perform its obligations hereunder and has sufficient experience and competence to do so;
- 3.163 is authorized to do business in the State of Texas and properly is licensed by all necessary governmental, public and quasi-public authorities having jurisdiction over it, the Work and the site of the Project;
- 3.164 is acting within its duly authorized powers to execute this Contract and execute the performance and obligations thereof; and
- 3.165 had directed its duly authorized representative(s) to visit the Site of the Work, familiarize itself with the local conditions under which the Work is to be performed and correlated its observations with the requirements of the Contract Documents.

ARTICLE IV. ADMINISTRATION OF THE CONTRACT

- 41 DESIGN CONSULTANT.** A Design Consultant is a person registered as an Architect pursuant to Tex. Occupations Code Ann., Chapter 1051, a Landscape Architect pursuant to Texas Occupations Code, Chapter 1052, and/or a person licensed as a professional Engineer pursuant to Texas

Occupations Code, Chapter 1001, or a firm employed by City to provide professional architectural or engineering services and exercising overall responsibility for the design of a Project or a significant portion thereof, and performing certain contract administration responsibilities as set forth in its contract and these General Conditions. If the employment of a Design Consultant is terminated, City shall employ a new Design Consultant whose status under the Contract Documents shall be that of the former Design Consultant.

42 ROLES IN ADMINISTRATION OF THE CONTRACT

4.2.1 City and Design Consultant shall provide administration of the Contract, as described in the Contract Documents, and Design Consultant shall be City's representative:

- (1) during construction;
- (2) until final payment is due; and
- (3) with City's concurrence, from time to time during the one-year period for correction of Work described in **Article XII** herein.

Design Consultant only shall have authority to act on behalf of City to the extent provided in the Contract Documents, unless otherwise modified in writing by City in accordance with other provisions of the Contract Documents.

4.2.2 City's instruction to Contractor may be issued through Design Consultant and City reserves the right to issue instructions directly to Contractor through the ODR or through other designated City representatives. Contractor understands City may modify the authority of such Design Consultant as provided in the terms of its contractual relationship with Design Consultant, and City shall, in such event, be vested with powers formerly exercised by such Design Consultant, provided written notice of such modification immediately shall be served on Contractor. Nothing herein shall authorize independent agreements between Contractor and Design Consultant, nor shall Design Consultant be deemed to have a legal relationship with Contractor.

4.2.3 Neither Design Consultant nor City shall have control over, charge of nor be responsible for the construction means, methods or techniques, or for the safety precautions, quality control program and other programs in connection with the Work, since these solely are Contractor's rights and responsibilities under the Contract Documents. Sequencing and procedures shall be coordinated and agreed upon by City, Design Consultant and Contractor and shall remain the responsibility of Contractor for implementation.

4.2.4 Design Consultant shall not be responsible for Contractor's failure to perform the Work in accordance with the requirements of the Contract Documents. Design Consultant shall not have control over, charge of and shall not be responsible for acts or omissions of Contractor, Subcontractor, their respective agents, employees or any other persons or entities performing portions of the Work.

4.2.5 City and Contractor shall endeavor to communicate with each other directly, through Design Consultant and/or through the ODR about matters arising out of or relating to the Contract. Communications by and with Design Consultant's Consultants shall be through Design Consultant. Communications by City and Design Consultant with Contractor's employees Subcontractors and material suppliers shall be through Contractor. All communications by and with City's separate contractors shall be through City.

4.2.6 Design Consultant shall review and approve or take other appropriate action upon Contractor's submittals such as Shop Drawings, Product Data and Samples, but only for the limited purpose of

checking for conformance with information given and the design concept expressed in the Contract Documents. Design Consultant shall perform these reviews in a timely fashion so as to not delay the Work. Design Consultant promptly shall respond to submittals such as Shop Drawings, Product Data and Samples pursuant to the procedures set forth in the Project Specifications. Review of such submittals is not conducted for the purpose of determining the accuracy and completeness of equipment or systems, all of which remain the responsibility of Contractor as required by the Contract Documents. Design Consultant's review of Contractor's submittals shall not relieve the Contractor of the obligations under **Sections 3.3, 3.5 and 3.12** herein. Design Consultant's review shall not constitute approval of safety precautions or, unless otherwise specifically stated by Design Consultant, any construction means, methods, techniques, sequences or procedures. Design Consultant's approval of a specific item shall not indicate approval of an assembly of which the item is a component.

- 4.2.7 Upon written request of City or Contractor, Design Consultant shall issue its interpretation of the requirements of the Plans and Specifications. Design Consultant's response to such requests shall be made in writing within a time limit agreed upon or otherwise with reasonable promptness. If no agreement is made concerning the time within which interpretations required of Design Consultant shall be furnished in compliance with this **Section 4.2**, then no delay shall be recognized on account of any failure by Design Consultant to furnish such interpretations except for actual substantiated delays, for which Contractor is not responsible, occurring more than fifteen (15) calendar days after written request is made for the interpretations.
- 4.2.8 Interpretations and decisions of Design Consultant shall be consistent with the intent of and reasonably inferable from the Contract Documents and shall be in writing or in the form of drawings.
- 4.2.9 Design Consultant's decisions on matters relating to aesthetic effect shall be final if consistent with the intent expressed in the Contract Documents and not expressly overruled in writing by City.

4.3 CLAIMS AND DISPUTES

- 4.3.1 **DEFINITION.** A Claim is a demand or assertion by one of the Parties seeking, as a matter of right, an adjustment or interpretation of Contract terms, payment of money, extension of time or other relief, with respect to the terms of the Contract. The term "Claim" also includes other disputes and matters in question between City and Contractor arising out of or relating to the Contract. Claims must be initiated by written notice. Every Claim of Contractor, whether for additional compensation, additional time or other relief including, but not limited to, claims arising from concealed conditions, shall be signed and sworn to by an authorized corporate officer (if not a corporation, then an official of the company authorized to bind Contractor by his/her signature) of Contractor, verifying the truth and accuracy of the Claim. The responsibility to substantiate a Claim shall rest with the Party making the Claim.
- 4.3.2 **TIME LIMIT ON CLAIMS.** Except for those Claims resulting from unusually severe weather, as addressed in **Section 4.3.6**, or other circumstances specifically exempted or modified herein, Contractor Claims must be initiated within twenty (20) calendar days after occurrence of the event giving rise to such Claim. Claims by Contractor must be submitted by written notice to both City and Design Consultant. Claims by City must be submitted by written notice to Contractor. Failure by Contractor to submit written notice of the Claim within twenty (20) calendar days shall constitute a waiver of such Claim.
- 4.3.3 **CONTINUING CONTRACT PERFORMANCE.** Pending final resolution of a Claim, except as otherwise agreed in writing or as provided in **Sections 4.5.1** or as otherwise provided herein, Contractor shall proceed diligently with performance of the Contract and City shall continue to make payments in accordance with the Contract Documents.

434 **CLAIMS FOR CONCEALED OR UNKNOWN CONDITIONS.** If conditions are encountered at the Site which either are subsurface or are otherwise concealed physical conditions which were not known to Contractor and which differ materially from those indicated in the Contract Documents or in the reports of investigations and tests of subsurface and latent physical conditions provided by City to Contractor prior to the preparation by Contractor of its Bid, as referred to above, or are unknown physical conditions of an unusual nature, which differ materially from those ordinarily found to exist and generally recognized as inherent in construction activities of the character provided for in the Contract Documents in the general vicinity of the Project site, then Contractor promptly shall notify City and Design Consultant of such conditions before conditions are disturbed, and in no event more than three (3) workdays after first observation of the conditions. Upon notification by Contractor, Design Consultant promptly shall investigate such conditions and report its findings to City. If City and Contractor cannot agree on an adjustment to the Contract Sum or Contract Time, the adjustment shall be subject to dispute resolution pursuant to **Section 4.4** herein.

435 **CLAIMS FOR ADDITIONAL COST.** If Contractor wishes to make a Claim for an increase in the Contract Sum, written notice as provided in this **Section 4.3** shall be given and must be accepted by City before proceeding to execute the Work, provided prior notice is not required for Claims relating to an emergency endangering life or property. Contractor shall file a Claim in accordance with this **Section 4.3** if Contractor believes additional cost is involved for reasons including, but not limited to:

- (1) a written interpretation from Design Consultant;
- (2) an order by City to stop the Work where Contractor was not at fault;
- (3) a written order for a minor change in the Work issued by Design Consultant;
- (4) failure of payment by City;
- (5) termination of the Contract by City for convenience;
- (6) City's suspension; or
- (7) other reasonable grounds.

436 **CLAIMS FOR ADDITIONAL TIME**

436.1 If Contractor wishes to make Claim for an increase in the Contract Time, written notice, as required in this **Section 4.3**, shall be given. Contractor's Claim shall include an estimate of probable impact of delay on progress of the Work in accordance with **Section 3.10.11** herein. In the case of a continuing delay, only one Claim is necessary.

436.2 Contractor shall be entitled to an extension of the Contract Time for delays or disruptions due to unusually severe weather in excess of weather normally experienced at the job site, as determined from climatological data set forth by National Weather Service and which affects the Project's critical path. Contractor shall bear the entire economic risk of all weather delays and disruptions. Contractor shall not be entitled to any increase in the Contract Sum by reason of such delays or disruptions. Requests for an extension of time, pursuant to this **Section 4.3.6**, shall be submitted to City and Design Consultant not later than the fifteenth (15th) calendar day of the month following the month during which the delays or disruptions occurred and shall include documentation and all details reasonably available, demonstrating the nature and duration of the delays or disruptions and their effect on the critical path of the Schedule. Any time extension granted to Contractor for either Vertical or Horizontal projects under **Section 4.3.6** shall be non-compensatory. Time extensions will not be granted for rain, wind, flood, or other natural weather event or phenomena of normal intensity for the locality where the Work is performed. For purpose of determining the extent of a delay attributable to unusual rainfall,

the number of rain days experienced during a month will be compared to the normal weather recorded and expected for Austin, Texas. Normal rainfall compiled by the State climatologist, based on U.S. Weather Bureau Records for Austin, Texas, is considered to be a part of this Calendar Day Contract, and is not a justification for an extension of Contract Time. Listed below as follows are the mean number of days in which there occurred 0.01 inch or more of precipitation, which are considered herein as normal rainfall:

January	8 days
February	8 days
March	7 days
April	7 days
May	9 days
June	6 days
July	5 days
August	5 days
September.....	8 days
October.....	8 days
November.....	8 days
December	8 days

437 **INJURY OR DAMAGE TO PERSON OR PROPERTY.** If either Party to the Contract suffers injury or damage to person or property because of an act or omission of the other Party or an act or omission of others for whose acts such other Party legally is responsible (including, with respect to City, the acts or omissions of City’s separate contractors), written notice of such injury or damage, whether or not insured, shall be given to the other Party within a reasonable time not exceeding three (3) calendar days after the discovery of the injury or damage. The written notice shall provide sufficient detail to enable the other Party to investigate the injury or damage.

438 **CHANGE IN UNIT PRICES.** As applicable, if unit prices are stated in the Contract Documents or subsequently are agreed upon by City and Contractor and if quantities originally contemplated are materially changed in a proposed Change Order or Field Work Directive, such that the application of such unit prices to quantities of Work proposed shall cause substantial inequity to City or Contractor, the applicable unit prices shall be equitably adjusted. Unit prices established in the Contract documents may only be modified when a Change Order or Field Work Directive causes a material change in quantity to a Major Bid Item. A Major Bid Item is defined as a single bid item constituting a minimum of five percent (5%) of the total contract value. A material change in quantity is defined as an increase or decrease of twenty five percent (25%) or more of the units of an individual bid item or an increase or decrease of twenty five percent (25%) or more of the dollar value of a lump sum bid item. Revised unit pricing only shall apply to the quantity of a major bid item in excess of a twenty five percent (25%) increase or decrease of the original Contract quantity.

439 **CLAIMS FOR CONSEQUENTIAL AND OTHER DAMAGES.** Except as otherwise provided in this Contract, in calculating the amount of any Claim or any measure of damages for breach of contract (such provision to survive any termination following such breach), the following standards shall apply both to Claims by Contractor and to Claims by City:

439.1 No consequential, indirect, incidental, punitive or exemplary damages shall be allowed, whether or not foreseeable, regardless of whether based on breach of contract, tort (including negligence), indemnity, strict liability or other bases of liability.

439.2 No recovery shall be based on a comparison of planned expenditures to total actual expenditures, on estimated losses of labor efficiency, on a comparison of planned man loading

to actual man loading, based on cumulative impact or on any other similar analysis, including without limitation the measured mile approach, used to show total cost or other damages.

- 43.9.3 Damages are limited to extra costs specifically shown to directly have been caused by a proven wrong for which the other Party is claimed to be responsible.
- 43.9.4 The maximum amount of any recovery for delay, to the extent damages for delay are not otherwise disallowed by the terms of the Contract Documents, shall be as is provided in **Article VIII** herein.
- 43.9.5 No damages shall be allowed for home office overhead or other home office charges or any *Eichleay* formula calculation, except or unless as expressly authorized by the Contract Documents.
- 43.9.6 No profit shall be allowed on any damage Claim, except or unless as expressly authorized by the Contract Documents.

43.10 **SUBCONTRACTOR PASS-THROUGH CLAIMS.** In the event any Subcontractor of Contractor asserts a Claim to Contractor that Contractor seeks to pass through to City under the Contract Documents, any entitlement to submit and assert the Claim as to City shall be subject to:

43.10.1 the requirements of **Section 4.3** herein of these General Conditions; and 4.3.10, including the following additional three (3) requirements listed below, all three of said additional requirements shall be conditions precedent to the entitlement of Contractor to seek and assert such Claim against City:

(1) Contractor shall:

- (a) have direct legal liability as a matter of contract, common law or statutory law to Subcontractor for the claim Subcontractor is asserting; or
- (b) have entered into a written liquidating agreement with Subcontractor, prior to the Claim's occurrence, under which Contractor has agreed to be legally responsible to the Subcontractor for pursuing the assertion of such Claim against City under said Contract and for paying to Subcontractor any amount that may be recovered, less Contractor's included markup (subject to the limits in the Contract Documents for any markup). The relationship, liability or responsibilities shall be identified in writing by Contractor to City at the time such Claim is submitted to City and a copy of any liquidating agreement shall be included by Contractor in the Claim submittal materials.

(2) Contractor shall have reviewed the Claim of the Subcontractor prior to its submittal to City and independently shall have evaluated such Claim in good faith to determine the extent to which the Claim is believed in good faith to be valid. Contractor shall inform City in writing that it has made a review, evaluation and determination the Claim is being made in good faith and the claim is believed to be valid.

(3) Subcontractor making the Claim to Contractor shall certify to both Contractor and City Subcontractor has compiled, reviewed and evaluated the merits of such Claim and the Claim is believed in good faith by Subcontractor to be valid. A copy of the certification by Subcontractor shall be included by Contractor in the Claim submittal materials.

43.10.2 Any failure of Contractor to comply with any of the foregoing requirements and conditions

precedent with regard to any such Claim shall constitute a waiver of any entitlement to submit or pursue such Claim.

43.103 Receipt and review of a Claim by City under this **Section 4.3** shall not be construed as a waiver of any defenses to the Claim available to City under the Contract Documents or at law.

43.11 **CITY'S RIGHT TO ORDER ACCELERATION AND TO DENY CLAIMED AND APPROPRIATE TIME EXTENSIONS, IN WHOLE OR IN PART.** Contractor acknowledges and agrees Substantial Completion of the Work by or before the Scheduled Completion Date is of substantial and critical importance to City. The following provisions, therefore, shall apply:

43.11.1 If Contractor falls behind the approved construction schedule for whatever reason, City shall have the right, in City's sole discretion, to order Contractor to develop a schedule recovery plan to alter its work sequences or to otherwise accelerate its progress in such a manner as to achieve Substantial Completion on or before the Contract Time completion date or such other date as City reasonably may direct. Upon receipt, Contractor shall take any and all action necessary to comply with City's order. In such event, any possible right, if any, of Contractor to additional compensation for any acceleration shall be subject to the terms of this **Section 4.3.11**.

43.11.2 In the event City agrees Contractor is entitled to an extension of Contract Time and Contractor properly has initiated a Claim for a time extension in accordance with **Section 4.3.6** herein, City shall have the right, in City's sole discretion, to deny any portion of Contractor's Claim for an extension of Contract Time and order Contractor to exercise its commercially reasonable efforts to achieve Substantial Completion on or before the contractual date established, but for the existence of the event giving rise to the Claim, by giving written notice to Contractor provided within fourteen (14) calendar days after receipt of Contractor's Claim. If City denies Contractor's claim for an extension of Contract Time under this **Section 4.3.11**, either in whole or in part, Contractor shall proceed to prosecute the Work in such a manner as to achieve Substantial Completion on or before the then- existing Scheduled Completion Date. If, after initiating good faith acceleration efforts and it is shown, through no fault of Contractor, Contractor fell behind on the approved construction schedule and Contractor still is unable to achieve Substantial Completion within the originally scheduled Contract Time, City shall not be entitled to Liquidated Damages. Nothing in this **Section 4.3.11.2** shall prohibit Contractor from filing a Claim for an extension of time Contractor feels it may be owed.

43.11.3 If City orders Contractor to accelerate the Work under **Section 4.3.11.2** herein, and Contractor would have been entitled to a time extension for a reason specifically allowed under the Contract Documents for an amount of time that would have justified approval by City if not for the need and right to complete the Project within the stipulated period, Contractor may initiate a Claim for schedule recovery or acceleration costs, pursuant to **Section 4.3.1** herein. Any resulting Claim for these costs properly initiated by Contractor under **Section 4.3.1** herein shall be limited to those reasonable and documented direct costs of labor, materials, equipment and supervision solely and directly attributable to the actual recovery or acceleration activity necessary for Contractor to bring the Work back within the then existing approved construction schedule. These direct costs of Contractor include, but are not limited to, the premium portion of overtime pay for additional crew, shift, or equipment costs, if requested in advance by Contractor and approved in writing by City. A percentage markup for the prorated cost of premium on the existing performance and payment bonds and required insurance, profit and field overhead, not to exceed the markups permitted by this Contract, shall be allowed on the claimed costs. **NO OTHER MARKUP FOR PROFIT, OVERHEAD (INCLUDING, BUT NOT LIMITED TO, HOME OFFICE OVERHEAD) OR ANY OTHER COSTS SHALL BE ALLOWED ON ANY ACCELERATION CLAIM.** City shall not be liable for any costs

related to an acceleration claim other than those described in this **Section 4.3.11**.

43.12 **NO WAIVER OF GOVERNMENTAL IMMUNITY.** Nothing in this Contract shall be construed to waive City's Governmental Immunity from a lawsuit, which Immunity is expressly retained to the extent it is not clearly and unambiguously waived by State law.

44 RESOLUTION OF CLAIMS AND DISPUTES

44.1 Claims by Contractor against City and Claims by City against Contractor, including those alleging an error or omission by Design Consultant but excluding those arising under **Section 10.3** and **Section 10.4** herein, shall be referred initially to Design Consultant for consideration and recommendation to City.

44.2 An initial recommendation by Design Consultant shall be required as a condition precedent to mediation or litigation of all Claims by the Parties arising prior to the date final payment is due, unless thirty (30) calendar days have passed after the Claim has been referred to Design Consultant with no recommendation having been rendered by Design Consultant.

44.3 Design Consultant shall review Claims and, within ten (10) work days of receipt of a Claim, take one or more of the following actions:

- (1) request additional supporting data from the Party making the Claim;
- (2) issue an initial recommendation;
- (3) suggest a compromise; or
- (4) advise the Parties that Design Consultant is unable to issue an initial Recommendation, due to a lack of sufficient information or conflict of interest.

44.4 Following receipt of Design Consultant's initial recommendation regarding a Claim, City and Contractor shall attempt to reach agreement as to any adjustment to the Contract Sum and/or Contract Time. If no agreement is reached, either Party may request mediation of the dispute, pursuant to **Section 45** herein.

44.5 If Design Consultant requests either or any Party to provide a response to a Claim or to furnish additional supporting data, such requested Party shall provide a response or the requested supporting data to Design Consultant, advise Design Consultant when the response or supporting data shall be furnished or advise Design Consultant that no response or supporting data shall be furnished.

44.6 With receipt of all information requested by Design Consultant, Design Consultant shall review the Claim and all received information within ten (10) calendar days of receipt of the information and shall take one of the following actions:

- (1) issue a recommendation;
- (2) suggest a compromise; or
- (3) advise the Parties Design Consultant is unable to issue a recommendation due to lack information or conflict of interest.

44.7 Upon Design Consultant's action or inaction, the Parties may agree to accept recommendations made by either Party or may request mediation of the dispute pursuant to **Section 4.5** herein.

44.8 **WAIVER OF LIEN.** It is understood that, by virtue of this Contract, no mechanic, contractor, material man, artisan or laborer, whether skilled or unskilled, ever shall, in any manner, have a claim or acquire

any lien upon the building or any of the improvements of whatever nature or kind so erected or to be erected by virtue of this Contract, nor upon any of the land upon which said building or any of the improvements are so erected, built or situated.

4.5 ALTERNATIVE DISPUTE RESOLUTION

- 4.5.1 **CONTINUATION OF WORK PENDING DISPUTE RESOLUTION.** Each Party is required to continue to perform its obligations under this Contract pending the final resolution of any dispute arising out of or relating to this Contract, unless it would be impossible or impracticable under the circumstances then present.
- 4.5.2 **REQUIREMENT FOR SENIOR LEVEL NEGOTIATIONS.** Before invoking mediation or any other alternative dispute process set forth herein, the Parties to this Contract agree that they first shall try to resolve any dispute arising out of or related to this Contract through discussions directly between those senior management representatives within their respective organizations who have overall managerial responsibility for the Project. Both City and Contractor agree that this step shall be a condition precedent to use of any other alternative dispute resolution process. If the Parties' senior management representatives cannot resolve the dispute within thirty (30) calendar days after a Party delivers a written notice of such dispute to the other, then the Parties shall proceed with the alternative dispute resolution process contained in **Section 4.5** herein, including mediation and/or litigation. All negotiations pursuant to this **Section 4.5** are confidential and shall be treated as compromise and settlement negotiations for purposes of applicable rules of evidence.
- 4.5.3 **MEDIATION.** In the event that City and/or Contractor contend that the other has committed a material breach of this Contract, or the Parties cannot reach a resolution of a claim or dispute pursuant to **Section 4.4** herein, as a condition precedent to filing a lawsuit, either Party shall request mediation of the dispute with the following requirements:
- 4.5.3.1 Request for mediation shall be in writing and shall request that the mediation commence not less than thirty (30) or more than ninety (90) calendar days following the date of the request, except upon agreement of both Parties.
- 4.5.3.2 In the event City and Contractor are unable to agree to a date for the mediation or to the identity of the mediator(s) within thirty (30) calendar days following the date of the request for mediation, all conditions precedent in this **Section 4.5** shall be deemed to have occurred.
- 4.5.3.3 The Parties shall share the mediator's fee and any mediation filing fees equally. Venue for any mediation or lawsuit arising under this Contract shall be in Travis County, Texas. Any agreement reached in mediation shall be enforceable as a settlement agreement in any court having jurisdiction thereof. No provision of this Contract shall waive any immunity or defense. No provision of this Contract is consent to a suit.

ARTICLE V. SUBCONTRACTORS

5.1 DEFINITION

A Subcontractor is defined and used herein as a person or entity that has a direct contract with the Contractor to perform a portion of the Work at the site. The term "Subcontractor" is referred to throughout the Contract Documents as if singular in number and means a Subcontractor, Sub-Consultant or an authorized representative of Subcontractor or Sub-Consultant. The term "Subcontractor" does not include a separate contractor or Subcontractor of a separate contractor.

5.2 AWARD OF SUBCONTRACTS AND OTHER CONTRACTS FOR PORTIONS OF THE WORK

- 5.2.1 Contractor shall, prior to entering into an agreement with such Subcontractor, notify City in writing of the names of all proposed first-tier Subcontractors for the Work.
- 5.2.2 Contractor shall not employ any Subcontractor or other person or organization (including those who are to furnish the principal items of materials or equipment), whether initially or as a substitute, against whom City may have reasonable objection. A Subcontractor or other person or organization identified in writing to City, prior to the Notice of Award and not objected to in writing by City prior to the Notice of Award, shall be deemed acceptable to City. Acceptance of any Subcontractor, other person or organization by City shall not constitute a waiver of any right of City to reject defective Work. If City, after due investigation, has reasonable objection to any Subcontractor, other person or organization proposed by Contractor after the Notice of Award, Contractor shall be required to submit an acceptable substitute. Contractor shall not be required to employ any Subcontractor, other person or organization against whom Contractor has reasonable objection.
- 5.2.3 Contractor shall be fully responsible to City for all acts and omissions of its Subcontractors, persons and organizations directly or indirectly employed by them and persons and organizations for whose acts any of them may be liable to the same extent that Contractor is responsible for the acts and omissions of persons directly employed by Contractor. Nothing in the Contract Documents shall create any contractual relationship between City and any Subcontractor or other person or organization having a direct contract with Contractor, nor shall it create any obligation on the part of City to pay or to see to the payment of any moneys due any Subcontractor or other person or organization, except as may otherwise be required by law. City may furnish to any Subcontractor or other person or organization, to the extent practicable, evidence of amounts paid to Contractor on account of specific Work done.
- 5.2.4 The divisions and sections of the Specifications, as well as the identifications of any Drawings, shall not control Contractor in dividing the Work among Subcontractors or delineating the Work to be performed by any specific trade.
- 5.2.5 All Work performed for Contractor by a Subcontractor shall be performed pursuant to an appropriate agreement between Contractor and Subcontractor, which specifically binds Subcontractor to the applicable terms and conditions of the Contract Documents for the benefit of City.

5.3 SUB-CONTRACTUAL RELATIONS

- 5.3.1 By appropriate agreement, written where legally required for validity, Contractor shall require each Subcontractor, to the extent of the Work to be performed by Subcontractor, to be bound to Contractor by the same terms and conditions of the Contract Documents. Through that binding commitment, Subcontractor shall assume all the obligations and responsibilities, including the responsibility for safety of Subcontractor's Work and workers, which Contractor, by these Documents, assumes toward City and Design Consultant. Each Subcontractor agreement shall preserve and protect the rights of City and Design Consultant under the Contract Documents, with respect to the Work to be performed by Subcontractor, so that subcontracting thereof shall not prejudice such rights. Where appropriate, Contractor shall require each Subcontractor to enter into similar agreements with Sub-Subcontractors. Contractor shall make available to each proposed Subcontractor, prior to the execution of all Subcontractor agreement(s), copies of the Contract Documents to which Subcontractor(s) shall be bound. Subcontractors similarly shall make copies of applicable portions of such documents available to their respective proposed Sub-Subcontractors.

5.4 CONTINGENT ASSIGNMENT OF SUBCONTRACTS

Each Subcontractor agreement for a portion of the Work assigned by Contractor to City shall provide:

- 5.4.1 an assignment is effective only after termination of the Contract by City and only for those Subcontractor agreements which City accepts by notifying Subcontractor and Contractor in writing; and
- 5.4.2 an assignment is subject to the prior rights of the Surety, if any, obligated under bond relating to the Contract.
- 5.4.3 upon any such assignment, if the Work has been suspended for more than ninety (90) calendar days, Subcontractor's compensation equally shall be adjusted for increase in cost resulting from the suspension.

ARTICLE VI. CONSTRUCTION BY CITY OR BY SEPARATE CONTRACTS

6.1 CITY'S RIGHT TO PERFORM CONSTRUCTION AND TO AWARD SEPARATE CONTRACTS

- 6.1.1 City reserves the right to perform construction or operations related to the Project with City's own forces and to award separate contracts in connection with other portions of the Project or other construction or operations on the Site under General Conditions of the Contract identical or substantially similar to these. If Contractor claims that a delay or additional cost is involved, due to such action by City, Contractor shall make a Claim as provided in **Section 4.3** herein.
- 6.1.2 When separate contracts are awarded for different portions of the Project or for other construction or operations on the Project Site, the term "Contractor" in the Contract Documents in each case shall mean the Contractor that executes each separate City-Contractor contract.
- 6.1.3 City shall provide for coordination of the activities of City's own forces and of each separate contractor with the Work of Contractor and Contractor fully shall cooperate with said coordination. Contractor shall participate with other separate contractors and City in reviewing all construction schedules when directed by City to do so. Contractor shall make any revisions to its construction schedule deemed necessary after said joint review and mutual agreement. The revised construction schedules then shall constitute the schedules to be used by Contractor, separate contractors and City until subsequently revised.
- 6.1.4 Unless otherwise provided in the Contract Documents, when City and City's own forces perform construction or operation related to the Project, City shall be subject to the same obligations and to have the same rights that apply to Contractor under these General Conditions and the Contract Documents.

6.2 MUTUAL RESPONSIBILITY

- 6.2.1 Contractor shall afford City and City's separate contractor(s) reasonable opportunity for the introduction and storage of materials and equipment, the performance of their activities and the coordination of Contractor's construction and operations with theirs, as required by the Contract Documents.
- 6.2.2 If part of Contractor's Work depends upon the construction or operations by City or a separate

contractor for the proper execution or results, Contractor shall, prior to proceeding with that portion of the Work, promptly report to City apparent discrepancies or defects in such other construction that would render it unsuitable for such proper execution and results. Failure of Contractor to so report shall constitute an acknowledgment that City's separate contractor's completed or partially completed construction is fit and proper to receive Contractor's Work, except as to defects not then reasonably discoverable.

- 6.2.3 City shall be reimbursed by Contractor for costs incurred by City which are payable to a separate contractor because of delays, improperly timed activities or defective construction of Contractor. City shall be responsible to Contractor for costs incurred by Contractor because of delays, improperly timed activities and damage to the Work or defective construction of City's separate contractor(s). Any such Claims shall be processed in accordance with **Section 4.3** herein.
- 6.2.4 Contractor promptly shall remedy any damage wrongfully caused by Contractor or its Subcontractor(s) to any completed or partially completed construction or to property of City or City's separate contractor(s), as provided herein.
- 6.2.5 City and each separate contractor shall have the same responsibilities for cutting and patching as are described for Contractor in **Section 3.14** herein.
- 6.3 CITY'S RIGHT TO CLEAN UP.** If a dispute arises among or between Contractor, City's separate contractor(s) and City, as to the responsibility under their respective contracts for maintaining the premises and surrounding area free from waste materials and rubbish, City may clean up and those costs shall be allocated amongst those parties determined responsible.

ARTICLE VII. CHANGES IN THE WORK

7.1 GENERAL

- 7.1.1 Changes in the Work may be accomplished, after the execution of the Contract and without invalidating the Contract, by Change Order, Field Work Directive/Force Account or order for a minor change in the Work that does not affect the Contract Time or the Contract Sum, subject to the limitations stated in this **Article VII** and elsewhere in the Contract Documents.
- 7.1.2 A Change Order shall be based upon agreement between City and Contractor; a Field Work Directive requires a directive by City and, if necessary, Design Consultant and may or may not be agreed to by Contractor; and an order for a minor change in the Work that does not affect the Contract Time or the Contract Sum may be issued by City.
- 7.1.3 Changes in the Work shall be performed under applicable provisions of the Contract Documents and Contractor promptly shall proceed with the changed Work, unless otherwise provided in a Change Order, Field Work Directive or order for a minor change in the Work or in this **Article VII**.
- 7.1.4 Changes resulting from Change Orders, Field Work Directives or orders for minor changes shall be recorded by Contractor on the As-Built record documents.

7.2 CHANGE ORDERS

- 7.2.1 A Change Order is a written modification of the Contract signed by both City and Contractor (and approved by City Council, if required) that authorizes an addition, deletion or revision in the Work or an adjustment in the Contract Sum or the Contract Times and is issued on or after the Effective Date of the

Contract.

- 722 Methods used in determining adjustments to the Contract Sum may include those listed in **Section 7.3.4** herein.
- 723 Acceptance of a Change Order by Contractor shall constitute a full accord and satisfaction for any and all claims and costs of any kind, whether direct or indirect, including, but not limited to impact, delay or acceleration damages arising from the subject matter of the Change Order, regardless of the number or scope of Change Orders associated with the Project. Each Change Order shall be specific and final as to prices and any extensions of time, with no reservations or other provisions allowing for future additional money or time as a result of the particular changes identified and fully compensated in the Change Order. The execution of a Change Order by Contractor shall constitute conclusive evidence of Contractor's agreement to the ordered changes in the Work, cost and additional time, if any. This Contract, as amended, forever releases any Claim against City for additional time or compensation for matters relating to or arising out of or resulting from the Work included within or affected by the executed Change Order, whether foreseen or unforeseen. This release of any Claim applies to Claims related to the cumulative impact of all Change Orders and to any Claim related to delay or the effect of a change on unchanged Work.
- 724 City or Design Consultant shall prepare Change Orders and Field Work Directives and shall have authority to order minor changes in the Work not involving an adjustment in the Contract Sum or an extension of the Contract Time. Such changes shall be effected by written order, which Contractor promptly shall carry out and record on the As-Built record documents.
- 725 Contractor and Subcontractors shall be entitled to include overhead and profit in any Change Order only as provided by Project Specifications and subject to the other terms and limitations of this Contract. Maximum allowable markups for Change Order pricing, when said pricing is not determined through unit prices, are established as follows:
- 7.2.5.1 **Labor.** Contractor shall be allowed the documented payroll rates for each hour laborers and foremen actually shall be engaged in the Work. Contractor shall be allowed to receive an additional twenty five percent (25%) as compensation, based on the total wages paid said laborers and foremen. No charge shall be made by Contractor for organization or overhead expenses. For costs of premiums on public liability and workers compensation insurance(s), Social Security and unemployment insurance taxes, an amount equal to fifty five percent (55%) of the sum of the labor cost, excluding the twenty five percent (25%) documented payroll rate compensation allowed herein, shall be the established maximum allowable labor burden cost. No charge for superintendence shall be made unless considered necessary and approved by City or a Change Order includes an extension of the Contract Time.
- 7.2.5.2 **Materials.** Contractor shall be allowed to receive the actual cost, including freight charges, for materials used on such Work, including an additional twenty five percent (25%) of the actual cost as compensation. When material invoices indicate an available discount, the actual cost shall be determined as the invoiced price less the available discount.
- 7.2.5.3 **Equipment.** For Contractor-owned machinery, trucks, power tools or other equipment, necessary for use on Change Order work, the Rental Rate Blue Book for Construction Equipment (hereafter referred to as "Blue Book") rate, as modified by the following, shall be used to establish Contractor's allowable hourly rental rates. Equipment used shall be at the rates in effect for each section of the Blue Book at the time of use. The following formula shall be used to compute the hourly rates:

$$H = \frac{M \times R1 \times R2}{176} + OP$$

Where

- H = Hourly Rate
- M = Monthly Rate
- R1 = Rate Adjustment Factor
- R2 = Regional Adjustment Factor
- OP = Operating Costs

If Contractor-owned machinery and/or equipment is not available and equipment is rented from an outside source, the hourly rate shall be established by dividing the actual invoice cost by the actual number of hours the equipment is involved in the Work. City reserves the right to limit the hourly rate to comparable Blue Book rates. When the invoice specifies the rental rate does not include fuel, lubricants, repairs and servicing, the Blue Book hourly operating cost shall be allowed to be added for each hour the equipment operates. The allowable equipment hourly rates shall be paid for each hour the equipment is involved in the Work and an additional maximum of fifteen percent (15%) may be added as compensation.

7.2.5.4 **Subcontractor Markups.** Contractor shall be allowed administrative cost only when extra Work, ordered by City, is performed by a Subcontractor or Subcontractors. The maximum allowable payment for administrative cost shall not exceed five percent (5%) of the total Subcontractor work. Off-duty peace officers and patrol cruisers shall be considered as Subcontractors, with regard to consideration of allowable contractor markups.

7.3 FIELD WORK DIRECTIVES

- 731 A Field Work Directive is a written directive signed by City and, if necessary, Design Consultant directing a change in the Work prior to agreement on an adjustment, if any, in the Contract Sum or Contract time, or both. City may, by Field Work Directive and without invalidating the Contract, order changes in the Work within the general scope of the Contract consisting of additions, deletions or other revisions, with any changes to the Contract Sum and/or the Contract Time to be adjusted according to the terms of this **Section 7.3**.
- 732 A Field Work Directive shall be used in the absence of total agreement on the terms of a Change Order. City shall issue a Field Work Directive to Contractor with a defined Not-To-Exceed dollar amount for the scope of Work defined.
- 733 Upon receipt of a Field Work Directive, Contractor promptly shall proceed with the change in the Work involved and, in writing, advise City of the Contractor's agreement or disagreement with the method, if any, provided in the Field Work Directive for determining the proposed adjustment in the Contract Sum or Contract Time.
- 734 If the Field Work Directive provides for an adjustment to the Contract Sum, the adjustment shall be based on one of the following methods, as applicable:
- 7.3.4.1 mutual acceptance of a lump sum properly itemized and supported by sufficient substantiating data to permit evaluation;
 - 7.3.4.2 prices, including unit prices, stated in the Contract Documents or subsequently agreed upon;

7.3.4.3 cost to be determined in a manner agreed upon by City and Contractor and a mutually acceptable fixed or percentage fee; or

7.3.4.4 as provided in **Section 7.3.6** herein.

735 If Contractor does not respond promptly or disagrees with the method for adjustment in the Contract Sum, the method and the adjustment shall initially be determined by Design Consultant on the basis of reasonable costs and savings attributable to the change including, in case of an increase in the Contract Sum, as applicable, a reasonable allowance for overhead and profit. In such case, and also under **Section 7.3.4.3** herein, Contractor shall keep and present, in such form as City may prescribe, an itemized and detailed accounting together with appropriate supporting data. Unless otherwise provided in the Contract Documents, costs for the purposes of this **Section 7.3.5** shall be limited to the following:

7.3.5.1 costs of all labor, including social security, old age and unemployment insurance, fringe benefits required by Law, agreement or custom, and workers' compensation insurance;

7.3.5.2 costs of all materials, supplies and equipment, including cost of transportation, storage installation, maintenance, dismantling and removal, whether incorporated or consumed;

7.3.5.3 rental costs of all machinery and equipment, exclusive of hand tools, whether rented from Contractor or others, including costs of transportation, installation, minor repairs and replacements, dismantling and removal;

7.3.5.4 expenses incurred in accordance with Contractor's standard personnel policy for travel approved in writing by City in advance;

7.3.5.5 costs of premiums for all bonds and insurance, permit fees and allowable sales, use or similar taxes related to the Work;

7.3.5.6 all additional costs of supervision and field office personnel directly attributable to the change; and

7.3.5.7 all payments made by the Contractor to Subcontractors.

736 The amount of credit to be allowed by Contractor to City for a deletion or change which results in a net decrease in the Contract Sum shall be actual net cost of the deleted or change Work, plus Contractor's allocated percent for profit and overhead, as confirmed by Design Consultant, subject to any equitable adjustment recommended by Design Consultant and approved by City. When both additions and credits covering related Work or substitutions are involved in a change, the allowance for overhead and profit shall be figured on the basis of net increase or decrease, if any, with respect to that change.

737 If City and Contractor agree with the determination made by Design Consultant concerning the adjustments in the Contract Sum and Contract Time, or otherwise reach agreement upon the adjustments, such agreement shall be effective immediately and shall be recorded by preparation and execution of an appropriate Change Order.

738 If City and Contractor cannot reach an agreement on either an adjustment on the Contract Sum and Contract Time, pursuant to an issued Field Work Directive, City and Contractor shall execute a Change Order for the adjustment on the Contract Sum or Contract Time, if any, the Parties do agree upon for the Work performed and Contractor reserves the right to file a Claim for any disagreements in Contract Sum or Contract Time not addressed in the Change Order, pursuant to **Section 4.3** herein. If City and

Contractor cannot agree on both the adjustment in the Contract Sum and the Contract Time associated with an issued Field Work Directive, City unilaterally shall file a Change Order listing City's adjustments in the Contract Sum and/or Contract Time and Contractor reserves the right to file a Claim for payment and/or time, pursuant to **Section 4.3** herein.

739 Maximum allowable markups for Field Work Directives shall follow the allowable markups established in **Section 7.2.5** herein.

7.4 ORDER FOR MINOR CHANGES TO THE WORK. City or Design Consultant both shall have authority to order minor changes in the Work not involving adjustment in the Contract Sum or extension of the Contract Time and not inconsistent with the intent of the Contract Documents. Such changes shall be effected by written order and shall be binding on City and Contractor. Contractor promptly shall carry out such written orders and record such changes in the As-Built drawings.

7.5 TIME REQUIRED TO PROCESS CHANGE ORDERS

751 All responses by Contractor to proposal requests from City or Design Consultant shall be accompanied by a complete itemized breakdown of costs. Responses to proposal requests shall be submitted sufficiently in advance of the required work to allow City and Design Consultant a minimum of thirty (30) calendar days after receipt by City to review the itemized breakdown and to prepare or distribute additional documents as may be necessary. Each of Contractor's responses to proposal requests shall include a statement that the cost and additional time described and requested in Contractor's response represents the complete, total and final cost and additional Contract Time associated with the extra work, change, addition to, omission, deviation, substitution or other grounds for seeking extra compensation or additional time under the Contract Documents, without reservation or further recourse.

752 All Change Orders require written approval by either City or City Council or, where authorized by the state law and City ordinance, by City's City Manager or designee, pursuant to Administrative Action. The approval process requires a minimum of forty-five (45) calendar days after submission to City in final form with all supporting data. Receipt of a submission by City does not constitute acceptance or approval of a proposal, nor does it constitute a warranty that the proposal shall be authorized by City or City Council Resolution or Administrative Action. **THE TIME REQUIRED FOR THE APPROVAL PROCESS SHALL NOT BE CONSIDERED A DELAY AND NO EXTENSIONS TO THE CONTRACT TIME OR INCREASE IN THE CONTRACT SUM SHALL BE CONSIDERED OR GRANTED AS A RESULT OF THIS PROCESS.** Pending the approval of a Change Order as described above, Contractor shall proceed with the work under a pending Change Order only if directed in writing to do so by CITY.

ARTICLE VIII. TIME

8.1 PROGRESS AND COMPLETION

8.1.1 **TIME LIMITS STATED IN THE CONTRACT DOCUMENTS ARE OF THE ESSENCE OF THE CONTRACT.** Time is of the essence in this Contract as completion of the Work within the Contract Time, as revised in accordance with the Contract, is a significant component of the City's consideration and inducement to enter into the same with Contractor. By executing the Contract, Contractor confirms that the Contract Time is a reasonable period for performing the Work.

8.1.2 Contractor shall proceed with the Work expeditiously using adequate forces and shall achieve Milestones and Substantial Completion, as applicable, and Final Completion within the Contract Time.

8.2 DELAYS AND EXTENSIONS OF TIME

- 8.2.1 Neither City nor Contractor, except as provided for in this **Section 8.2**, shall be liable to the other for any delay to Contractor's Work by reason of fire, act of God, riot, strike, or similar event of force majeure, or any other cause beyond the respective party's reasonable control. Should any of these listed factors delay the Work's critical path, as evidenced by a Time Impact Analysis developed by Contractor and verified by Design Consultant, Program Manager and City, Contractor shall receive an extension of the Contract Times equal to the delay if a written Claim is made within twenty (20) calendar days of the delaying event and subsequently granted by City, all in accordance with **Section 4.3** herein. Under no circumstances shall City be liable to pay Contractor any compensation for such delays. Note that any request for an extension of time due to delays or disruption caused by unusually severe weather are addressed in **Section 4.3.6.2** herein.
- 8.2.2 Should Contractor be delayed solely and exclusively by the intentional act or default of City or Design Consultant, whether foreseen or unforeseen, and should any of these factors delay the Project's critical path, as evidenced by a Time Impact Analysis developed by Contractor and verified by Design Consultant, Program Manager and City, Contractor shall receive an extension of the Contract Time equal to the verified delay or portion thereof if a written Claim is made within twenty (20) calendar days of the occurrence of the intentional act or default of City or Design Consultant and subsequently granted by City, all in accordance with **Section 4.3** herein. In addition, Contractor, upon timely notice of its Claim to the City, with substantiation by City and Design Consultant and upon approval of City, shall be entitled to an adjustment of Contract Sum for its Project facilities, limited to directly incurred incremental daily costs attributable to machine or equipment rentals, barricade or fence rentals, and similar non-labor related costs, and field management overhead expenses on a per diem basis for the particular Project delayed and for the period of the critical path delay directly and exclusively attributable to a City-caused event. Any such adjustment to Contract Sum shall be subject to the limitations of this Contract, including without limitation, **Section 4.3** herein. In no event shall Contractor be entitled to home office, other off-site expenses or any other damages of any kind from whatever source derived.

Contractor shall be entitled to standby costs only when directed to standby in writing by City. Standby costs may include actual documented Project overhead costs of Contractor, consisting of administrative and supervisory expenses incurred at the Project Site. Standby equipment costs shall not be allowed during periods when the equipment would otherwise have been idle. For Projects where Contractor is working a five (5) day Work Week, as defined in **Section 3.1.4** herein, with a Working Day measured from 6:00 a.m. to Dusk Monday through Friday, no more than eight (8) hours of standby time shall be paid during a 24-hour day, no more than forty (40) hours shall be paid per week for standby time and no more than one hundred and seventy six (176) hours per month shall be paid of standby time. Standby time shall be computed at fifty percent (50%) of the rates found in the Rental Rate Blue Book for Construction Equipment and shall be calculated by dividing the monthly rate found in the Blue Book by 176, then multiplying that total by the regional adjustment factor and the rate adjustment factor. Operating costs shall not be charged by Contractor.

For Projects where Contractor is working a six (6) day Work Week, as defined in **Section 3.1.4** herein with a Working Day measured from 6:00 a.m. to Dusk Monday through Saturday, no more than eight (8) hours of standby time shall be paid during a 24-hour day, no more than forty eight (48) hours shall be paid per week for standby time and no more than two hundred and eight (208) hours per month shall be paid of standby time. Standby time shall be computed at fifty percent (50%) of the rates found in the Rental Rate Blue Book for Construction Equipment and shall be calculated by dividing the monthly rate found in the Blue Book by 208, then multiplying that total by the regional adjustment factor and the rate adjustment factor. Operating costs shall not be charged by Contractor.

- 8.23 Claims relating to time shall be made in accordance with applicable provisions of **Section 4.3** herein.
- 8.24 This Contract does not permit the recovery of damages by Contractor for delay, disruption or acceleration, other than those described in **Section 8.2.2** and **Section 4.3** herein and limited to those justified by a Time Impact Analysis. Contractor agrees that it shall be fully compensated for all delays solely by an extension of non-compensatory time or as contemplated in **Section 8.2.2** herein.

ARTICLE IX. PAYMENTS AND COMPLETION

91 CONTRACT SUM. The Contract Sum is stated in the Contract and, including authorized adjustments, is the total maximum not-to-exceed amount payable by City to Contractor for performance of the Work under the Contract Documents. Contractor accepts and agrees that all payments pursuant to this Contract are subject to the availability and appropriation of funds by the Pflugerville City Council. If funds are not available and/or appropriated, this Contract shall immediately be terminated with no liability to any Party to this Contract.

92 SCHEDULE OF VALUES

- 92.1 A Schedule of Values for all of the Work shall be submitted by Contractor and shall include quantities and prices of items which, when added together, equal a contract Price and subdivides the Work into component parts in sufficient detail to serve as the basis for progress payments during performance of the Work. Where applicable, overhead and profit shall be included as a separate line item.
- 92.2 Before the first Application for Payment, Contractor shall submit to City and Design Consultant a Schedule of Values allocated to various portions of the Work, prepared in such form and supported by such data to substantiate its accuracy as City and Design Consultant may require. This schedule, unless objected to by Design Consultant or City, shall be used as a basis for reviewing Contractor's Applications for Payment.

93 APPLICATIONS FOR PAYMENT

- 93.1 Contractor shall submit Applications for Payment to City electronically, at minimum, every thirty (30) days throughout the duration of the Project. Contractor electronically shall attach to its Application for Payment all data substantiating Contractor's right to payment as City or Design Consultant may require, such as copies of requisitions from Subcontractors and material suppliers reflecting retainage, if provided for in the Contract Documents, and reflecting a deduction for Liquidated Damages, if applicable. Applications for Payment shall not include requests for payment for portions of the Work which Contractor does not intend to pay to a Subcontractor or material supplier, unless such Work has been performed by others whom Contractor intends to pay.
- 93.2 Unless otherwise provided in the Contract Documents, payments shall be made on account of materials and equipment delivered and suitably stored at the Site for subsequent incorporation in the Work and verified by City. If approved in advance in writing by City, payment similarly may be made for materials and equipment suitably stored off the Site at a location agreed upon in writing and verified by City. Payment for materials and equipment stored on or off the Site shall be conditioned upon compliance by Contractor with procedures reasonably satisfactory to City to establish City's title to such materials and equipment or otherwise protect City's interest. Contractor solely shall be responsible for payment of all costs of applicable insurance, storage and transportation to the site for materials and equipment stored off the site.
- 93.3 Contractor warrants that, upon submittal of an Application for Payment, all Work for which payment

previously has been received from City shall, to the best of Contractor's knowledge, information and belief, be free and clear of liens, claims, security interests or encumbrances in favor of Contractor, Subcontractors, material suppliers or other persons or entities making a claim by reason of having provided labor, materials and equipment relating to the Work. **CONTRACTOR SHALL INDEMNIFY AND HOLD CITY HARMLESS FROM ANY LIENS, CLAIMS, SECURITY INTEREST OR ENCUMBRANCES FILED BY CONTRACTOR, SUBCONTRACTORS OR ANYONE CLAIMING BY, THROUGH OR UNDER CONTRACTOR OR SUBCONTRACTOR(S) FOR ITEMS COVERED BY PAYMENTS MADE BY CITY TO CONTRACTOR.**

- 934 By submission of an Application for Payment, Contractor certifies that there are no known liens or bond claims outstanding as of the date of said Application for Payment, that all due and payable bills with respect to the Work have been paid to date or are included in the amount requested in the current application and, except for such bills not paid but so included, there is no known basis for the filing of any liens or bond claims relating to the Work and that releases from all Subcontractors and Contractor's material men have been obtained in such form as to constitute an effective release of lien or claim under the laws of the State of Texas covering all Work theretofore performed and for which payment has been made by City to Contractor; provided if any of the foregoing is not true and cannot be certified, Contractor shall revise the certificate as appropriate and identify all exceptions to the requested certifications.

94 PAY APPLICATION APPROVAL

- 94.1 Design Consultant shall, within five (5) business days after the electronic receipt of Contractor's Application for Payment, either approve the Application for Payment or reject the Application for Payment and state on the electronic notification to Contractor and City the Design Consultant's reasons for withholding approval, as provided in **Section 9.5.1** herein.
- 94.2 The certification of an Application for Payment shall constitute a representation by Design Consultant to City, based on Design Consultant's evaluation of the Work and the data comprising the Application for Payment, that the Work has progressed to the point indicated and that, to the best of Design Consultant's knowledge, information and belief, the quality of the Work is in accordance with the Contract Documents. The foregoing representations are subject to an evaluation of the Work for conformance with the Contract Documents upon Substantial Completion, to results of subsequent tests and inspections, to correction of minor deviations from the Contract Documents prior to completion and to any specific qualifications expressed by Design Consultant. The issuance of a Certificate for Payment further shall constitute a representation that Contractor is entitled to payment in the amount certified. However, the issuance of a Certificate for Payment shall not be a representation Design Consultant has:
- (1) made exhaustive or continuous on-site inspections to check the quality or quantity of the Work;
 - (2) reviewed construction means, methods, techniques, sequences or procedures;
 - (3) reviewed copies of requisitions received from Subcontractors and material suppliers and other data requested by City to substantiate Contractor's right to payment; or
 - (4) made an examination to ascertain how or for what purpose Contractor has used money previously paid on account of the Contract Sum.

95 DECISIONS TO REJECT APPLICATION FOR PAYMENT

- 95.1 The Application for Payment may be rejected to protect City for any of the following reasons:

9.5.1.1 Work not performed or defective;

9.5.1.2 third party claims filed or reasonable evidence indicating a probable filing of such claims for which Contractor is responsible hereunder unless security acceptable to City is provided by Contractor;

9.5.1.3 failure of Contractor to make payments properly to Subcontractors or for labor, materials or equipment;

9.5.1.4 reasonable evidence that the Work cannot be completed for the unpaid balance of the Contract Sum and Contractor has failed to provide City adequate assurance of its continued performance within a reasonable time after demand;

9.5.1.5 damage to City or another contractor;

9.5.1.6 reasonable evidence that the Work shall not be completed within the Contract Time, and that the unpaid balance would not be adequate to cover actual or Liquidated Damages for the anticipated delay;

9.5.1.7 persistent failure by Contractor to carry out the Work in accordance with the Contract Documents;

9.5.1.8 the applicable Liquidated Damages were not included in the Application for Payment;

9.5.1.9 billing for unapproved/unverified materials stored off Site; or

9.5.1.10 a current schedule update has not been submitted by Contractor.

952 City shall not be deemed in default by reason of rejecting Application for Payment as provided for in **Section 9.5.1** herein.

96 PROGRESS PAYMENTS

961 After the final approval of the Application for Payment, City may make payment in the manner and within the time provided in the Contract Documents.

962 During the latter part of each month, as the Work progresses on all City Contracts regardless of Contract Sum, City and Contractor shall determine the cost of the labor and materials incorporated into the Work during that month and actual invoiced cost of Contractor-acquired materials stored on the Project Site, and/or within off-site storage facilities either owned or leased by Contractor. Upon receipt of a complete and mathematically accurate Application for Payment from Contractor, City shall make payments, in accordance with **Article IX** herein, to Contractor within thirty (30) calendar days on Contracts totaling four hundred thousand dollars (\$400,000.00) or less, based upon such cost determination and at the Contract prices in a sum equivalent to ninety percent (90%) of each such invoice. The remaining ten percent (10%) retainage shall be held by City until the Final Completion. However, where the Contract amount exceeds four hundred thousand dollars (\$400,000.00), installments shall be paid to Contractor at the rate of ninety-five percent (95%) of each monthly invoice within thirty (30) calendar days of City receipt of a complete and mathematically accurate Application for Payment from the Contractor, and the retainage held until Final Completion shall be five percent (5%).

- 963 City's payment of installments shall not, in any way, be deemed to be a final acceptance by City of any part of the Work, shall not prejudice City in the final settlement of the Contract account or shall not relieve Contractor from completion of the Work herein provided.
- 964 Contractor shall, within ten (10) calendar days following receipt of payment from City, pay all bills for labor and materials performed and furnished by others in connection with the construction, furnishing and equipping of the improvements and the performance of the work, and shall, if requested, provide City with written evidence of such payment. Contractor's failure to make payments or provide written evidence of such payments within such time shall constitute a material breach of this Contract, unless Contractor is able to demonstrate to City bona fide disputes associated with the unpaid Subcontractor(s) or supplier(s) and its/their work. Contractor shall include a provision in each of its subcontracts imposing the same written documentation of payment obligations on its Subcontractors as are applicable to Contractor hereunder, and if City so requests, shall provide copies of such Subcontractor payments to City. If Contractor has failed to make payment promptly to Contractor's Subcontractors or for materials or labor used in the Work for which City has made payment to the Contractor, City shall be entitled to withhold payment to Contractor to the extent necessary to protect City.
- 965 City and/or Design Consultant shall, if practicable and upon request, furnish to Subcontractor information regarding percentages of completion or amounts applied for by Contractor and action taken thereon by City and Design Consultant on account of portions of the Work done by such Subcontractor.
- 966 Neither City nor Design Consultant shall have an obligation to pay or to see to the payment of money to a Subcontractor, except as may otherwise be required by law, if any.
- 967 Payments to material suppliers shall be treated in a manner similar to that provided in **Section 9.6.2**, **Section 9.6.3** and **Section 9.6.4** herein regarding Subcontractors.
- 968 A Certificate for Payment, a progress payment or a partial or entire use or occupancy of the Project by City shall not constitute acceptance of Work that was not performed or furnished in accordance with the Contract Documents.
- 969 Contractor shall, as a condition precedent to any obligation of City under this Contract, provide to City payment and performance bonds in the full penal amount of the Contract, in accordance with Texas Government Code Chapter 2253.

97 SUBSTANTIAL COMPLETION

- 97.1 Substantial Completion is defined as the stage in the progress of the Work when the Work, or a designated portion thereof, which City agrees to accept separately, sufficiently is complete, in accordance with the Contract Documents, so City may occupy or utilize the Work or a designated portion thereof for its intended use. In the event Substantial Completion is not achieved by the designated date, or the date extended by issued and accepted Change Order(s), City may withhold payment of sums necessary to pay the estimated Liquidated Damages due City. City shall be entitled, at any time, to deduct out of any sums due to Contractor any or all Liquidated Damages due City in accordance with the Contract between City and Contractor.
- 97.2 When Contractor considers that the Work, or a portion thereof which City agrees to accept separately, is Substantially Complete, Contractor shall prepare and submit to City and Design Consultant a preliminary comprehensive list of items to be completed or corrected prior to Final Completion and final payment. Failure to include an item on such list does not alter the responsibility of the Contractor to complete all Work in accordance with the Contract Documents.

- 973 Upon receipt of Contractor's list of items to be completed or corrected, City and Design Consultant shall make a Site inspection to determine whether the Work or designated portion thereof is Substantially Complete. If City's or Design Consultant's inspection discloses any item, whether or not it was included on Contractor's list of items to be completed or corrected, which is not sufficiently complete or correct in accordance with the Contract Documents so that City may occupy or utilize the Work or designated portion thereof for its intended use, Contractor shall, before issuance of the Certificate of Substantial Completion, complete or correct such item upon written notification by City or Design Consultant. In such case, Contractor then shall submit a request for another inspection by City and Design Consultant to determine Substantial Completion and Contractor shall be responsible for all costs incurred and associated with re-inspection.
- 974 When the Work, or the designated portion thereof which City agrees to accept separately, is Substantially Complete, Design Consultant or City shall prepare a Certificate of Substantial Completion (Vertical Projects) or a Letter of Conditional Approval (Horizontal Projects) which shall:
- (1) establish the date of Substantial Completion (which shall be the date on which the Work met the requirements under the Contract Documents for Substantial Completion);
 - (2) establish responsibilities of City and Contractor, as agreed to by City and Contractor, for security, maintenance, heat, utilities, damage to the Work and insurance; and
 - (3) confirm the time limit by which Contractor shall complete all items on the list accompanying the Certificate.

Warranties required by the Contract Documents shall commence on the date of Substantial Completion of the Work, or the designated portion thereof, unless otherwise provided in the Certificate of Substantial Completion.

98 PARTIAL OCCUPANCY OR USE

- 98.1 City may occupy or use any completed or partially completed portion of the Work at any stage of the Work when such partially completed portion is designated by separate agreement with Contractor, provided such occupancy or use is consented to by the insurer, as required under **Section 11.2.5** herein and authorized by public authorities having jurisdiction over the Work. Such partial occupancy or use may commence whether or not the portion is Substantially Complete, provided City and Contractor have accepted in writing the responsibilities assigned to each of them for security, maintenance, heat, utilities, damage to the Work and insurance and have agreed in writing concerning the period for correction of the Work and commencement of warranties required by the Contract Documents. When Contractor considers a portion of the Work to be Substantially Complete, Contractor shall prepare and submit a list of items to be completed or corrected prior to Final Completion and final payment and submit such list to City and Design Consultant, as provided under **Section 9.7.2** herein. Consent of Contractor to partial occupancy or use shall not be unreasonably withheld, conditioned or delayed. The state of the progress of the Work shall be determined by written agreement between City and Contractor or, if no agreement is reached, by the decision of Design Consultant.
- 98.2 Immediately prior to such partial occupancy or use, City, Contractor and Design Consultant collectively shall inspect the area to be occupied or portion of the Work to be used in order to determine and record the condition of the Work.
- 98.3 Unless expressly agreed upon in writing, partial occupancy or use of a portion or portions of the Work shall not constitute acceptance of Work not complying with the requirements of the Contract Documents.

984 Upon such partial occupancy or use, and upon Substantial Completion, City may assume responsibility for maintenance, security and insuring that portion of the Work that it has put into use.

985 Partial occupancy or use by City does not constitute Substantial Completion and does not start any warranty period(s).

99 FINAL COMPLETION AND FINAL PAYMENT

991 When all of the Work finally is completed and ready for final inspection, Contractor shall notify City and Design Consultant thereof in writing. Thereupon, City and Design Consultant shall make final inspection of the Work and, if the Work is complete in full accordance with this Contract and this Contract has been fully performed, the final Application for Payment may be submitted. If City and Design Consultant are unable to approve the final Application for Payment for reasons for which Contractor is responsible and City and Design Consultant are required to repeat a final inspection of the Work, Contractor shall be responsible for all costs incurred and associated with such repeat final inspection(s) and said costs may be deducted by City from the Contractor's retainage.

992 Contractor shall not be entitled to payment of retainage unless and until it submits to City its affidavit that the payrolls, invoices for materials and equipment, and other liabilities, to include Liquidated Damages, connected with the Work for which City or City's property might be responsible fully have been paid or otherwise satisfied or shall be paid from final payment; releases and waivers of liens from all Subcontractors of Contractor and of any and all other parties required by Design Consultant or City that either are unconditional or conditional on receipt of final payment; Certificates of insurance showing continuation of required insurance coverage; such other documents as City may request; and consent of Surety to final payment. A Retainage Checklist shall be provided by City to Contractor upon request.

993 If, after Substantial Completion of the Work, Final Completion of the Work materially is delayed through no fault of Contractor nor by Issuance of Change Orders affecting Final Completion of the Work, and Design Consultant so confirms, City shall, upon application by Contractor and certification by Design Consultant and without terminating the Contract, make payment of the balance due Contractor for that portion of the work fully completed and accepted. If the remaining balance for Work not fully completed or corrected is less than retainage stipulated in the Contract Documents, and if bonds have been furnished, the written consent of Surety to payment of the balance due for that portion of the Work fully completed and accepted shall be submitted by Contractor to Design Consultant, prior to certification of such payment. Such payment shall be made under the terms and conditions governing final payment, except that it shall not constitute a waiver of claims.

994 Request for final payment by Contractor shall constitute a waiver of all claims against City, except those previously made in writing and identified by the Contractor as unsettled at the time of final Application for Payment.

9.10 **ADDITIONAL INSPECTIONS.** In addition to any Liquidated Damages accrued by and payable to City by Contractor, City shall be entitled to deduct from the Contract Sum amounts due to Contractor by City to compensate Design Consultant for any additional inspections or services provided by Design Consultant, provided Design Consultant undertook these additional inspections or services due to the fault or negligence of Contractor if:

- (1) Design Consultant is required to make more than one inspection to determine if Substantial Completion has been achieved by Contractor; or
- Design Consultant is required to make more than one inspection to determine if Final Completion has been achieved by Contractor.

ARTICLE X. PROTECTION OF PERSONS AND PROPERTY

10.1 SAFETY PRECAUTIONS AND PROGRAMS

- 10.1.1 Contractor shall be responsible for initiating, maintaining and supervising all safety precautions and programs in connection with the performance of the Contract. Contractor shall develop a safety program applicable to each job site and to the Work to be done, review such program with City in advance of beginning the Work, and enforce such program at all times. Further, Contractor shall comply with all applicable laws and regulations including, but not limited to, the standards and regulations promulgated by the Secretary of Labor under the Occupational Safety and Health Act of 1970 (OSHA) and any other legislation enacted for the safety and health of Contractor employees. City shall have the right, but not the obligation, to inspect and verify Contractor's compliance with Contractor's responsibility for protecting the safety and health of its employees and Subcontractor.
- 10.1.2 Contractor shall notify City immediately, by telephone with prompt confirmation in writing, of all injuries and fatalities including, but not limited to, copies of all reports and other documents filed or provided to Contractor's insurers and the State of Texas in connection with such injuries or fatalities.
- 10.1.3 Contractor has adopted or shall adopt its own policy to assure a drug and alcohol-free work place while performing the Work. Contractor's employees, agents, and Subcontractors shall not perform any service for City while under the influence of alcohol or any controlled substance. Contractor, its employees, agents and Subcontractors shall not use, possess, distribute or sell illegal, illicit and/or prescribed controlled drugs or drug paraphernalia or misuse legitimate prescription drugs while on Site or performing the Work. Contractor, its employees, agents and Subcontractors shall not use, possess, distribute or sell alcoholic beverages while performing the Work or while on Site or performing the Work. Contractor shall remove any of its employees or Subcontractor employees from performing the Work or from the Site any time there is suspicion of alcohol and/or drug use, possession or impairment involving such employee and at any time an incident occurs where drug or alcohol use could have been a contributing factor. City has the right to require Contractor to remove employees or Subcontractor employees from performing the Work or from the Site any time cause exists to suspect alcohol or drug use. In such cases, Contractor's or Subcontractor's employees only may be considered for return to work after Contractor certifies, as a result of a for-cause test conducted immediately following a removal, said employee was in compliance with this Contract. Contractor shall not employ any individual, or shall not accept any Subcontractor employees, to perform the Work who either refuses to take or tests positive in any alcohol or drug test.
- 10.1.4 Contractor shall comply with all applicable federal, state and local drug and alcohol related laws and regulations (e.g., Department of Transportation regulations, Department of Defense Drug-free Work-free Workforce Policy, Drug-Free Workplace Act of 1988).
- 10.1.5 Both City and Contractor agree that these safety and health terms are of the highest importance and that a breach or violation of any of the terms of this **Section X** by Contractor or a Subcontractor shall be a material and substantial breach of this Contract. In the event that City shall determine that Contractor has breached or violated the terms of this Section, then City shall determine, immediately upon written notice to Contractor, whether the Work shall be suspended as a result thereof. If the Work is suspended, the Work shall not recommence until City is satisfied that the safety provisions hereof shall not be breached or violated thereafter. If City terminates the Contract as a result of such breach or violation, City and Contractor shall complete their obligations hereunder to one another in accordance with **Section 13.3** herein.
- 10.1.6 Nothing contained in this **Article X** shall be interpreted as creating or altering the legal duty of City to

Contractor or to Contractor's agents, employees, Subcontractors or third parties, or altering the status of Contractor as an independent contractor.

- 10.1.7 Notwithstanding either of the above provisions, or whether City exercises its rights set forth herein, City neither warrants nor represents to Contractor, Contractor's employees or agents, any Subcontractors or any other third party that Contractor's safety policy meets the requirements of any applicable law, code, rule or regulation, nor does City warrant that the proper enforcement of Contractor's policy shall insure that no accidents or injuries shall occur. In addition, any action by City under these provisions in no way diminishes any of Contractor's obligations under applicable law or the Contract Documents.

10.2 SAFETY OF PERSONS AND PROPERTY

- 10.2.1 Contractor shall take reasonable precautions for the safety of and shall provide reasonable protection to prevent damage, injury or loss to:
- 10.2.1.1 employees performing the Work and other persons who may be affected thereby;
 - 10.2.1.2 the Work and materials and equipment to be incorporated therein, whether in storage on or off the site, under the care, custody or control of Contractor or Contractor's Subcontractors or Sub-Subcontractors;
 - 10.2.1.3 other property at the site or adjacent thereto, such as trees, shrubs, lawns, walks, pavements, roadways, structures and utilities not designated for removal, relocation or replacement in the course of Construction; and
 - 10.2.1.4 the contents of a building or structure, when Contractor is working in, on or around an existing/operating City facility.
- 10.2.2 Contractor shall give notices and comply with applicable laws, ordinances, rules, regulations and lawful orders of public authorities bearing on safety of persons or property or their protection from damage, injury or loss.
- 10.2.3 Contractor shall erect and maintain, as required by existing conditions and performance of the Contract, reasonable safeguards for safety and protection, including posting danger signs and other warnings against hazards, promulgating safety regulations and notifying City and users of adjacent sites and utilities.
- 10.2.4 When use or storage of explosives or other hazardous materials or equipment or unusual methods are necessary for the execution of the Work, Contractor shall exercise extraordinary care and shall carry on such activities under the direct supervision of properly qualified personnel. Prior to the use of any explosives, Contractor shall submit a written blasting plan, shall obtain City's approval and shall comply with City's requirements for such use.
- 10.2.5 Contractor shall designate a responsible member of Contractor's organization at the site whose duty shall be the prevention of accidents. This person shall be Contractor's superintendent unless otherwise designated by Contractor in writing to City and Design Consultant.
- 10.2.6 Notwithstanding the delivery of a survey or other documents by City, Contractor shall perform all Work in such a manner so as to avoid damaging any utility lines, cables, pipes or pipelines on the property. Contractor acknowledges and accepts that the location of underground utilities (both public and private)

reflected on any City-provided Plans are not guaranteed and may not be completely accurate. Contractor shall locate and verify any and all utilities and associated service lines prior to beginning any Work. Contractor shall be responsible for and shall repair, at Contractor's own expense, any damage done to lines, cables, pipes and pipelines identified or not identified to Contractor.

10.3 EMERGENCIES

- 10.3.1 In an emergency affecting safety of persons or property, Contractor shall exercise its best efforts to act to prevent or minimize threatened damage, injury or loss. Additional compensation or extension of time claimed by Contractor on account of an emergency shall be determined, as provided in **Section 4.3** and **Article VII** herein.
- 10.3.2 If Contractor causes damage resulting in an issue of safety and/or security to public or private property, Contractor immediately shall repair any damage caused. If Contractor does not or shall not act immediately to repair the damage caused by Contractor to eliminate the resulting safety and/or security issue(s), City may act to repair the damage caused and deduct all costs associated with the repair from any money due Contractor.

10.4 PUBLIC CONVENIENCE AND SAFETY

- 10.4.1 Contractor shall place materials stored at the Project site and shall conduct the Work at all times in a manner that causes no greater obstruction to the public than is considered necessary by City. Sidewalks or streets shall not be obstructed, except by special permission of City. Materials excavated and construction materials or plants used in the performance of the Work shall be placed in a manner that does not endanger the Work or prevent free access to all fire hydrants, water mains and appurtenances, water valves, gas valves, manholes for the telephone, telegraph signal or electric conduits, wastewater mains and appurtenances and fire alarm or police call boxes in the vicinity.
- 10.4.2 City reserves the right to remedy any neglect on the part of Contractor, in regard to public convenience and safety, which may come to City's attention after twenty-four (24) hours-notice in writing to Contractor. In case of an emergency, City shall have the right to immediately remedy any neglect without notice. In either case, the cost of any work done by or for City to remedy Contractor's neglect shall be deducted by City from Contractor's Contract Sum. Contractor shall notify City and Design Consultant when any street is to be closed or obstructed. The notice shall, in the case of major thoroughfares or street upon which transit lines operate, be given at least forty-eight (48) hours in advance. City reserves the right to postpone and/or prohibit any closure or obstruction of any streets or thoroughfares, to the extent necessary for the safety and benefit of the traveling public. Contractor shall, when directed by City or Design Consultant, keep any street or streets in condition for unobstructed use by City departments. When Contractor is required to construct temporary bridges or make other arrangements for crossing over ditches or around structures, Contractor's responsibility for accidents shall include the roadway approaches as well as the crossing structures.
- 10.4.3 Contractor shall limit airborne dust and debris throughout the Project site and its duration. Contractor shall apply the necessary amounts of water or other appropriate substance required to maintain sufficient moisture content for dust control. For City horizontal projects, Contractor shall apply appropriate amounts of water or other appropriate substance to the base on streets under construction and on detours required to maintain sufficient moisture control in the surface layer for dust control.

- 10.5 PUBLIC UTILITIES AND OTHER PROPERTIES TO BE CHANGED.** In case it is necessary for Contractor to change or move the property of City or of any telecommunications or public utility, such property shall not be touched, removed or interfered with until ordered to do so by City. City

reserves the right to grant any public or private utility personnel the authority to enter upon the Project site for the purpose of making such changes or repairs to their property that may become necessary during the performance of the Work. City reserves the right of entry upon the Project site at any time and for any purpose, including repairing or relaying sewer and water lines and appurtenances, repairing structures and for making other repairs, changes, or extensions to any of City's property. City's actions shall conform to Contractor's current and approved schedule for the performance of the Work, provided that proper notification of schedule requirements has been given to City by Contractor.

10.6 ARRANGEMENT AND CHARGE FOR WATER FURNISHED BY CITY/ELECTRICITY FOR THE PROJECT/WIRELESS ACCESS

- 10.6.1 When Contractor desires to use City's water in connection with the Work, Contractor shall make complete and satisfactory arrangements with the Pflugerville Water Service Department and shall be responsible for the cost of the water Contractor uses. Where meters are required and used, the charge shall be at the regular established rate; where no meters are required and used, the charge shall be as prescribed by City ordinance, or where no ordinance applies, payment shall be based on estimates made by the representatives of the Pflugerville Water Service Department.
- 10.6.2 Contractor shall make complete and satisfactory arrangements for electricity and metered electrical connections with any applicable retail electric provider, in the event that separately metered electrical connections are required for the Project. Contractor shall pay for all electricity used in the performance of the Work through separate metered electrical connections obtained by Contractor through a retail electric provider.
- 10.6.3 If Contractor elects or is required by City to place and operate out of a construction trailer or office on the Project site, for which all related costs shall be borne by Contractor, Contractor shall provide for an electronic device to exchange data wirelessly via a local area computer network, to include high-speed internet connections (Wi-Fi access), for City personnel's use while on the Project site for the duration of the Project.

10.7 ENVIRONMENTAL COMPLIANCE

- 10.7.1 Contractor and its Subcontractors are deemed to have made themselves familiar with and at all times shall comply with any and all applicable federal, state or local laws, rules, regulations, ordinances and rules of common law now in effect (including any amendments thereto), relating to the environment, Hazardous Substances or exposure to Hazardous Substances including, but not limited to, the Comprehensive Environmental Response, Compensation and Liability Act of 1980, 42 U.S.C.A. §§ 9601, et seq.; the Hazardous Materials Transportation Act, 49 U.S.C.A. §§ 1801, et seq.; the Resource Conservation and Recovery Act of 1976, 42 U.S.C.A. §§ 6901, et seq.; the Federal Water Pollution Control Act, 33 U.S.C.A §§ 1201, et seq.; the Toxic Substances Control Act, 15 U.S.C.A. §§ 2601, et seq.; the Clean Air Act, 42 U.S.C.A. §§ 7401, et seq.; the Safe Drinking Water Act, 42 U.S.C.A. §§ 3808, et seq., and any current judicial or administrative interpretation of these laws, rules, regulations, ordinances or rules of common law including, but not limited to, any judicial or administrative order, consent decree or judgment affecting the Project.
- 10.7.2 In the event Contractor encounters on the Project Site materials reasonably believed to be a Hazardous Substance that have not been rendered harmless, and the removal of such materials is not a part of the scope of Work required under the Contract Documents, Contractor immediately shall stop Work in the affected area and immediately report in writing the facts of such encounter to City and Design Consultant. Work in the affected area shall not thereafter be resumed except by written order of City and written

consent of Contractor, unless and until the material is determined not to be a Hazardous Substance or the Hazardous Substance is remediated. Unless removal of such materials is a part of the scope of Work required under the Contract Documents, City shall remediate the Hazardous Substance with a separate contractor or through a Change Order with Contractor. If the Hazardous Substance exists in the affected area due to the fault or negligence of Contractor or any of its Subcontractors, Contractor shall be responsible for remediating the condition at the sole expense of Contractor. If applicable, such remediation shall be in accordance with Contractor's Spill Remediation Plan. An extension of the Contract Time for any delay in the progress schedule caused as a result of the discovery and remediation of a Hazardous Substance may be granted by City only if the Project critical path is affected and Contractor is not the source of the Hazardous Substance. Any request for an extension of the Contract Time related to the discovery and remediation of a Hazardous Substance is subject to the provisions of **Section 4.3** and **Article VIII** herein.

10.7.3 Contractor shall be responsible for identification, abatement, cleanup, control, removal, remediation and disposal of any Hazardous Substance brought into or onto the site by Contractor or any Subcontractor or Contractor's Supplier. Contractor shall obtain any and all permits necessary for the legal and proper handling, transportation and disposal of the Hazardous Substance and shall, prior to undertaking any abatement, cleanup, control, removal, remediation and/or disposal, notify City and Design Consultant so that they may observe the activities; provided, however, that it shall be Contractor's sole responsibility to comply with all applicable laws, rules, regulations or ordinances governing said activities.

10.8 ROAD CLOSURES AND DETOUR ROUTES. Contractor shall not begin construction of the Project or close any streets until adequate barricades and detour signs have been provided, erected and maintained in accordance with the detour route and details shown on the Project Plans. Contractor shall notify City forty-eight (48) hours in advance of closing any street to through traffic. Local traffic shall be permitted the use of streets under construction whenever feasible.

10.9 USE OF CITY STREETS. Contractor shall confine the movements of all steel-tracked equipment to the limits of the Project Site and any such equipment shall not be allowed use of City's streets unless being transported on pneumatic-tired vehicles. Any damage to City's streets caused by Contractor and/or Contractor's equipment, either outside the limits of the Project site or within the limits of the Project site but not within the limits of the current phase then being constructed, shall be repaired by Contractor at its own expense and as prescribed by City's Specifications and direction. If Contractor cannot or refuses to repair street damage caused by Contractor and/or Contractor's equipment, City may perform the repairs and all expenses incurred by City in performing the repairs shall be deducted from any money due or owed to Contractor.

10.10 MAINTENANCE OF TRAFFIC. In accordance with the approved traffic control plan and as specified in the Contract, Contractor shall:

- 10.10.1 keep existing roadways open to traffic or construct and maintain detours and temporary structures for safe public travel;
- 10.10.2 maintain the Work in passable condition, including proper drainage, to accommodate traffic;
- 10.10.3 provide and maintain temporary approaches and crossings of intersecting roadways in a safe and passable condition;
- 10.10.4 construct and maintain necessary access to adjoining property as shown in the Plans or as directed by City; and
- 10.10.5 furnish, install and maintain traffic control devices in accordance with the Contract.

- 10.10.6 The cost of maintaining traffic shall be subsidiary to the Project and shall not directly be paid for by City, unless otherwise stated in the Plans and Specifications. City shall notify Contractor if Contractor fails to meet the above traffic requirements. City may perform the work necessary for compliance, but any action by City shall not change the legal responsibilities of Contractor, as set forth in the Contract Documents. Any costs incurred by City for traffic maintenance shall be deducted from money due or owed to Contractor.

10.11 ABATEMENT AND MITIGATION OF EXCESSIVE OR UNNECESSARY CONSTRUCTION NOISE. Contractor shall ensure abatement and mitigation of excessive or unnecessary construction noise to the satisfaction of City and as prescribed by all applicable state and local laws.

10.12 INCIDENTAL WORK, CONNECTIONS, AND PASSAGEWAYS. Contractor shall perform all incidental Work necessary to complete and comply with this Contract including, but not limited to the following:

- 10.12.1 Contractor shall make and provide all suitable reconnections with existing improvements (generally excluding new connections with or relocation of utility services, unless specifically provided for otherwise in the Contract Documents) as are necessarily incidental to the proper completion of the Project;
- 10.12.2 Contractor shall provide passageways or leave open such thoroughfares in the Work Site as may be reasonably required by City; and
- 10.12.3 Contractor shall protect and guard same at its own risk and continuously shall maintain the Work Site in a clean, safe and workmanlike manner.

ARTICLE XI. INSURANCE AND BONDS

11.1 CONTRACTOR'S LIABILITY INSURANCE

- 11.1.1 Prior to the commencement of any work under this Contract, Contractor shall furnish copies of all required endorsements and completed Certificate(s) of Insurance to City's ODR or Department, which shall be clearly labeled "*Historic EST Lighting Project*" in the Description of Operations block of the Certificate. The Certificate(s) shall be completed by an agent and signed by a person authorized by that insurer to bind coverage on its behalf. City shall not accept a Memorandum of Insurance or Binder as proof of insurance. The Certificate(s) shall be signed by the Authorized Representative of the insurance carrier and shall include the agent's original signature and telephone number. The Certificate(s) shall be mailed, with copies of all applicable endorsements, directly from the insurer's authorized representative to City. City shall have no duty to pay or perform its obligations under this Contract until such Certificate(s) and endorsements have been received and approved by City's ODR or Department. No officer or employee of City, other than the City of Pflugerville's Risk Manager, shall have authority to waive any of these requirements.
- 11.1.2 City reserves the right to review the insurance requirements of this **Article XI** during the effective period of this Contract and to modify insurance coverages and limits when deemed necessary and prudent by the City of Pflugerville's Risk Manager based upon changes in statutory law, court decisions, or circumstances surrounding this Contract. In no instance will City allow modification whereby City may incur increased risk.
- 11.1.3 Contractor's financial integrity is of the utmost concern and interest to City; therefore, subject to Contractor's right to maintain reasonable deductibles in such amounts as are approved by City,

Contractor shall obtain and maintain in full force and effect, for the duration of this Contract and at Contractor's sole expense, insurance coverage written on an occurrence basis, unless otherwise indicated, by companies authorized to do business in the State of Texas and with an A.M Best's rating of no less than A- (VII), in the following types and for amounts not less than the amounts listed below:

TYPE	AMOUNTS
1. Workers' Compensation 2. Employers' Liability	Statutory \$1,000,000.00/\$1,000,000.00/ \$1,000,000.00
3. Commercial General Liability Insurance to include coverage for the following: a. Premises/Operations b. Products/Completed Operations c. Personal/Advertising Injury *d. Environmental Impairment/ Impact – sufficiently broad to cover disposal liability. *e. Explosion, Collapse, Underground	For <u>B</u> odily Injury and <u>P</u> roperty <u>D</u> amage of: \$1,000,000.00 per occurrence; \$2,000,000.00 General Aggregate, or its equivalent in Umbrella or Excess Liability Coverage
4. Business Automobile Liability: a. Owned/leased vehicles b. Non-owned vehicles c. Hired Vehicles	<u>C</u> ombined <u>S</u> ingle <u>L</u> imit for <u>B</u> odily <u>I</u> njury and <u>P</u> roperty <u>D</u> amage of \$1,000,000.00 per occurrence
5. *Professional Liability (Claims-made basis) To be maintained and in effect for no less than two years subsequent to the completion of the professional service.	\$1,000,000.00 per claim, to pay on behalf of the insured all sums which the insured shall become legally obligated to pay as damages by reason of any act, malpractice, error, or omission in professional services.
6. *Builder's Risk	All Risk Policy written on an occurrence basis for 100% replacement cost during construction phase of any new or existing structure.
*if applicable	

11.14 Contractor agrees to require, by written contract, all Subcontractors providing goods or services pursuant to performance on the Project to obtain the same categories of insurance coverage required of Contractor herein and provide a Certificate of Insurance and endorsement that names Contractor and City as additional insureds. Policy limits of the coverages carried by Subcontractors shall be determined as a business decision of Contractor. Contractor shall provide City with said Certificate and endorsement prior to the commencement of any work by the Subcontractor. This Subcontractor insurance provision may be modified by the City of Pflugerville's Risk Manager, without subsequent Pflugerville City Council approval, when deemed necessary and prudent, based upon changes in statutory law, court decisions, or circumstances surrounding this Contract. Such insurance coverage modification may be enacted by letter signed by the City of Pflugerville's Risk Manager, which shall become a part of this Contract for all purposes.

11.15 As they apply to the limits required by City, City shall be entitled, upon request and without expense, to receive copies of all insurance policies, declaration pages and all required endorsements associated with this Work. Contractor shall be required to comply with any such requests and shall submit requested documents to City at the address provided below within ten (10) calendar days. Contractor shall pay any and all costs incurred resulting from provision of said documents to City.

City of Pflugerville
Attn: Engineering
Department; ODR:
Brandon Pritchett
15500 Sun Light Near Way # B, Bldg. 6
Pflugerville, TX 78660

11.16 Contractor agrees that with respect to the above required insurance, all insurance policies are to contain or be endorsed to contain the following provisions:

- Name City, its officers, officials, employees, volunteers, and elected representatives as additional insureds by endorsement, with respect to operations and activities of, or on behalf of, the named insured performing under this Contract with City, with the exception of the workers' compensation and professional liability policies;
- Provide for an endorsement reflecting the "other insurance" clause shall not apply to the City of Pflugerville where City is an additional insured shown on the policy;
- Workers' compensation, employers' liability, general liability and automobile liability policies will provide a waiver of subrogation in favor of City.
- Provide advance written notice directly to City, at the address cited above, of any suspension or non-renewal in coverage of Contractor's insurance policy/policies associated with this Work and not less than ten (10) calendar days in advance notice for Contractor's nonpayment of premium(s).

11.17 Within five (5) calendar days of a suspension, cancellation or non-renewal of insurance coverage associated with this Work, Contractor shall provide a replacement Certificate(s) of Insurance and applicable endorsement(s) to City. City shall have the option to suspend Contractor's performance should there be a lapse in coverage at any time during this Contract. Failure to provide and to maintain the required insurance shall constitute a material breach of this Contract.

11.18 In addition to any other remedies City may have upon Contractor's failure to provide and maintain any insurance and/or policy endorsements to the extent and within the time herein required, City shall have the right to order Contractor to stop work hereunder and/or withhold any payment(s) which become due to Contractor hereunder until Contractor demonstrates compliance with the insurance requirements

hereof.

- 11.19 Nothing contained herein shall be construed as limiting in any way the extent to which Contractor may be held responsible for payments of damages to persons or property resulting from Contractor's or its Subcontractors' performance of the Work covered under this Contract.
- 11.1.10 Contractor accepts and agrees Contractor's insurance shall be deemed primary and non-contributory, with respect to any insurance or self-insurance carried by City, for liability arising out of Contractor's operations under this Contract.
- 11.1.12 Contractor understands, accepts and agrees the insurance required of Contractor by this Contract is in addition to and separate from any other obligation contained in this Contract and no claim or action by or on behalf of City shall be limited to insurance coverage provided.
- 11.1.13 Contractor and any of Contractor's Subcontractors are responsible for any and all damage to their own equipment and/or property.
- 11.1.14 Without limiting any of the other obligations or liabilities of Contractor under the Contract Documents, Contractor shall purchase and maintain, during the term of the Contract and at Contractor's own expense, the minimum liability insurance coverage described below with insurance companies duly authorized or approved to do business in the State of Texas and otherwise satisfactory to City. Contractor also shall require each Subcontractor performing work under the Contract, at Subcontractor's own expense, to maintain levels of insurance necessary and appropriate for the Work performed during the term of the Contract, said levels of insurance comply with all applicable laws. Subcontractor's liability insurance shall name Contractor, City and Design Consultant as additional insureds by using endorsement CG 20 26 or broader. Certificates of insurance complying with the requirements prescribed in **Section 11.1.2** herein shall show the existence of each policy, together with copies of all policy endorsements showing City and Design Consultant as an additional insured, and shall be delivered to City before any Work is started. Contractor promptly shall furnish, upon the request of and without expense to City, a copy of each policy required, including all endorsements, which shall indicate:
- 11.1.14.1 Workers' Compensation, with statutory limits, with the policy endorsed to provide a waiver of subrogation as to City; Employer's Liability Insurance of not less than \$1,000,000.00 for each accident, \$1,000,000.00 disease for each employee and \$1,000,000.00 disease policy limit;
- 11.1.14.2 Commercial General Liability Insurance, Personal Injury Liability, Independent Contractor's Liability and Products and Completed Operations and Contractual Liability covering, but not limited to, the liability assumed under the indemnification provisions of this Contract, fully insuring Contractor's (and/or Subcontractor's) liability for injury to or death of City's employees and all third parties, and for damage to property of third parties, with a combined bodily injury (including death) and property damage minimum limit of \$1,000,000.00 per occurrence, \$2,000,000.00 annual aggregate. If coverage is written on a claims-made basis, coverage shall be continuous (by renewal or extended reporting period) for no less than sixty (60) months following completion of the contract and acceptance of work by City. Coverage, including any renewals, shall have the same retroactive date as the original policy applicable to the Project. City shall be named as additional insured by using endorsement CG 20 26 or broader. The general liability policy shall include coverage extended to apply to completed operations and XCU hazards. The Completed Operations coverage must be maintained for a minimum of one (1) year after Final Completion and acceptance of the Work, with evidence of same filed with City. The policy shall include an endorsement CG2503 amendment of limits (designated project or premises) in order to extend the policy's limits specifically to the Project in question.

11.1.143 Business Automobile Liability Insurance, covering owned, hired and non-owned vehicles, with a combined bodily injury (including death) and property damage minimum limit of \$1,000,000 per occurrence. Such insurance shall include coverage for loading and unloading hazards.

11.1.144 Five (5) calendar days prior to a suspension, cancellation or non-renewal of any required line of insurance coverage, Contractor shall provide City a replacement certificate of insurance with all applicable endorsements included. If not so provided, City shall have the option to suspend Contractor.

11.1.15 If any insurance company providing insurance coverage(s) required under the Contract Documents for Contractor becomes insolvent or becomes the subject of any rehabilitation, conservatorship, liquidation or similar proceeding, Contractor immediately shall procure, upon first notice to Contractor or City of such occurrence and without cost to City, replacement insurance coverage before continuing the performance of the Work at the Project. Any failure to provide such replacement insurance coverage shall constitute a material breach of the Contract.

11.2 PROPERTY INSURANCE

11.2.1 As stated in **Section 11.1** Contractor shall obtain at its expense and maintain throughout the duration of the Project, All-Risk Builder's Risk Insurance, if the Project involves complete construction of a new building, or an All-Risk Installation Floater policy, if the Project involves materials and supplies needed for additions to, renovations or remodeling of an existing building. Coverage on either policy shall be All-Risk, including, but not limited to, Fire, Extended Coverage, Vandalism and Malicious Mischief, Flood (if located in a flood zone) and Theft, in an amount equal to one hundred percent (100%) of the insurable value of the Project for the Installation Floater policy, and one hundred percent (100%) of the replacement cost of the Project for the Builder's Risk policy. If an Installation Floater policy is provided, City shall be shown as a Joint Named Insured with respect to the Project. If a Builder's Risk policy is provided, the policy shall be written on a Completed Value Form, including materials delivered and labor performed for the Project. This policy shall be in the name of Contractor and naming City, Design Consultant and Subcontractors, as well as any Sub-Subcontractors, as additional insureds as their interests may appear. The policy shall have endorsements as follows:

11.2.1.1 This insurance shall be specific as to coverage and not contributing insurance with any permanent insurance maintained on the property.

11.2.1.2 Loss, if any, shall be adjusted with and made payable to Contractor or City and Contractor as trustee for the insureds as their interests may appear.

11.2.2 **BOILER AND MACHINERY INSURANCE.** If applicable, City shall purchase and maintain Boiler and Machinery Insurance required by the Contract Documents or by law, which specifically shall cover such insured objects during installation and until final acceptance by City. This insurance shall include the interests of City, Contractor, Subcontractors and Sub-Subcontractors in the Work, and City and Contractor shall be named insureds.

11.2.3 **LOSS OF USE INSURANCE.** City, at City's option, may purchase and maintain such insurance as shall insure City against loss of use of City's property due to fire or other hazards, however caused. City waives all rights of action against Contractor that it may now have or have in the future for loss or damage to City's property howsoever arising, including consequential losses due to fire or other hazards however caused.

11.2.4 Contractor shall provide to Design Consultant for delivery to City a Certificate of Insurance evidencing

all property insurance policies procured under this **Section 11.2** and all endorsements thereto, before any exposure to loss may occur.

- 1125 Partial occupancy or use in accordance with **Section 9.8** herein shall not commence until the insurance company/companies providing property insurance have consented to such partial occupancy or use by endorsement or otherwise. City and Contractor shall take reasonable steps to obtain consent of the insurance company/companies and shall take no action without mutual written consent with respect to partial occupancy or use that would cause cancellation, lapse or reduction of insurance.
- 1126 Contractor shall take all necessary precautions to ensure no damage shall result from operations to private or public property. All damages shall be repaired or replaced by Contractor at no additional cost to City.

11.3 PERFORMANCE, PAYMENT AND WARRANTY BONDS

- 113.1 Subject to the provisions of **Section 11.3.2** herein, Contractor shall, with the execution and delivery of the Contract, furnish and file with City, in the amounts required in this **Article XI**, the Surety Bonds described in **Sections 11.3.1.1 - 11.3.1.3** herein, with said Surety Bonds in accordance with the provisions of Chapter 2253, Texas Government Code, as amended. Each Surety Bond shall be signed by Contractor, as the Principal, as well as by an established corporate surety bonding company as surety, meeting the requirements of **Section 11.3.3** herein and approved by City. The Surety Bonds shall be accompanied by an appropriate Power-of-Authority clearly establishing the extent and limitations of the authority of each signer to so sign and shall include:

113.1.1 **PERFORMANCE BOND.** A good and sufficient Performance Bond in an amount equal to one hundred percent (100%) of the total Contract Sum, guaranteeing the full and faithful execution of the Work and performance of the Contract in accordance with Plans, Specifications and all other Contract Documents, including any extensions thereof, for the protection of City.

- 113.1.2 **PAYMENT BOND.** A good and sufficient Payment Bond in an amount equal to 100% of the total Contract Sum, guaranteeing the full and prompt payment of all claimants supplying labor or materials in the prosecution of the Work provided for in the Contract, and for the use and protection of each claimant.

- 113.1.3 **WARRANTY BOND.** A good and sufficient Warranty Bond in an amount equal to 35% of the total Contract Sum, including any change orders, covering and ensuring performance of the Contractor's warranty and guarantee obligations established under **Section 3.5** herein and as otherwise provided in the Contract Documents providing for the repair or remedy of all defects that are discovered or appear within a period of one (1) year from the date of Substantial or Final Completion or acceptance of the Work by City, as applicable, or lesser or longer periods as otherwise may be designated in the Contract Documents.

- 1132 If the Contract Sum, including City-accepted Alternates and allowances, if any, is greater than \$100,000.00, a Payment Bond and a Performance Bond equaling one hundred percent (100%) of the Contract Sum are mandatory and shall be provided by Contractor. If the Contract Sum is greater than \$50,000 but less than or equal to \$100,000, only a Payment Bond equaling one hundred percent (100%) of the Contract amount is mandatory; provided, however, Contractor also may elect to furnish a Performance Bond in the same amount if Contractor so chooses. If the Contract Sum is less than or equal to \$25,000, Contractor may elect not to provide Performance and Payment Bonds; provided, in such event, no money shall be paid by City to Contractor until Final Completion of all Work. If Contractor elects to provide the required Performance Bond and Payment Bond, the Contract Sum shall

be payable to Contractor through progress payments in accordance with these General Conditions.

- 1133 No surety shall be accepted by City that is in default, delinquent on any bonds or that is a party to any litigation against City. All bonds shall be made and executed on City's standard forms, shall be approved by City and shall be executed by not less than one (1) corporate surety that is authorized and admitted to do business in the State of Texas, is licensed by the State of Texas to issue surety bonds, is listed in the most current United States Department of the Treasury List of Acceptable Sureties and is otherwise acceptable to City. Each bond shall be executed by Contractor and the surety and shall specify that legal venue for enforcement of each bond exclusively shall lie in Travis County, Texas. Each surety shall designate an agent resident in Travis County, Texas to which any requisite statutory notices may be delivered and on which service of process may be had in matters arising out of the suretyship.
- 1134 The person or persons, partnership, company, firm, limited liability company, association, corporation or other business entity to whom the Contract is awarded shall, within ten (10) days after such award, sign the required Contract with City and provide the necessary surety bonds and evidence of insurance as required under the Contract Documents. No Contract shall be binding on City until:
- (1) it has been approved as to form by City's City Attorney;
 - (2) it has been authorized by City Council and executed by City's City Manager (if required);
 - (3) the Payment Bond and Performance Bond and evidence of the required insurance have been furnished to City by Contractor, as required by the Contract Documents; and
 - (4) a fully executed Contract has been delivered to Contractor (if required).
- 1135 The failure of Contractor to execute the Contract (if required) and deliver the required Bonds and evidence of insurance within ten (10) days after the Contract is awarded, or as soon thereafter as City can assemble and deliver the Contract and by the time the City-scheduled Pre-Construction meeting is held, shall, at City's option, constitute a material breach of Contractor's bid proposal and City may rescind the Contract award and collect or retain the proceeds of the bid security. By reason of the uncertainty of the market prices for materials and labor and it being impracticable and difficult to determine accurately the amount of damages occurring to City by reason of Contractor's failure to execute the Contract within ten (10) days and deliver bonds and insurance by the City-scheduled Pre-Construction meeting, the filing of a bid proposal shall constitute an acceptance of this **Section 11.3.5**. In the event City should re-advertise for bids, the defaulting Contractor shall not be eligible to bid and the lowest responsible bid obtained in the re-advertisement shall be the bid referred to in this **Section 11.3**.
- 11.4 'UMBRELLA' LIABILITY INSURANCE.** Contractor shall obtain, pay for and maintain Umbrella Liability Insurance during the Contract term, insuring Contractor for an amount of not less than \$5,000,000 per occurrence combined limit Bodily Injury (including death) and Property Damage, that follows form and applies in excess of the primary coverage required hereinabove. City and Design Consultant shall be named as additional insureds using endorsement CG 20 26 or broader. No aggregate shall be permitted for this type of coverage. The Umbrella Liability Insurance policy shall provide "drop down" coverage, where the underlying primary insurance coverage limits are insufficient or exhausted.

11.5 POLICY ENDORSEMENTS AND SPECIAL CONDITIONS

- 1151 Each insurance policy to be furnished by Contractor shall address the following required provisions within the certificate of insurance, which shall be reflected in the body of the insurance contract and/or by endorsement to the policy:

- 11.5.1.1 City and Design Consultant shall be named as additional insureds on all liability coverages, using endorsement CG 20 26 or broader. When City employs a Construction Manager on the Project, Contractor and Subcontractor(s) shall include the Construction Manager on all liability insurance policies to the same extent as City and Design Consultant are required to be named as additional insureds.
- 11.5.1.2 Within five (5) calendar days of a suspension, cancellation or non-renewal of any required line of insurance coverage, Contractor shall provide City a replacement certificate of insurance with all applicable endorsements included. City shall have the option to suspend Contractor's performance should there be a lapse in coverage at any time during the Contract.
- 11.5.1.3 The terms "Owner," "City" or "City of Pflugerville" shall include all authorities, boards, bureaus, commissions, divisions, departments and offices of City and the individual members, employees and agents thereof in their official capacities, while acting on behalf of City.
- 11.5.1.4 The policy phrase or clause "Other Insurance" shall not apply to City where City is an additional insured on the policy. The required insurance coverage furnished by Contractor shall be the primary insurance for all purposes for the Project, as well as the primary insurance for the additional insureds named in the required policies.
- 11.5.1.5 All provisions of the Contract Documents concerning liability, duty and standard of care, together with the indemnification provision, shall, to the maximum extent allowable in the insurance market, be underwritten with contractual liability coverage(s) sufficient to include such obligations with the applicable liability policies.
- 11.52 Concerning the insurance to be furnished by the Contractor, it is a condition precedent to acceptability that:
- 11.52.1 All policies must comply with the applicable requirements and special provisions of this **Article 11**.
- 11.52.2 Any policy evidenced by a Certificate of Insurance shall not be subject to limitations, conditions or restrictions deemed inconsistent with the intent of the insurance requirements set forth herein, and City's decision regarding whether any policy contains such provisions and contrary to this requirement shall be final.
- 11.52.3 All policies required are to be written through companies duly authorized and approved to transact that class of insurance in the State of Texas and that otherwise are acceptable to City.
- 11.53 Contractor agrees to the following special provisions:
- 11.53.1 Contractor hereby waives subrogation rights for loss or damage to the extent same are covered by insurance. Insurers shall have no right of recovery or subrogation against City, it being the intention that the insurance policies shall protect the Parties to the Contract and be primary coverage for all losses covered by the policies. This waiver of subrogation shall be included, by endorsement or otherwise, as a provision of all policies required under this **Article XI**.
- 11.53.2 Insurance companies issuing the insurance policies and Contractor shall have no recourse whatsoever against City for payment of any premiums or assessments for any deductibles, as all such premiums and assessments solely are the responsibility and risk of Contractor.
- 11.53.3 Approval, disapproval or failure to act by City, regarding any insurance supplied by Contractor

or any Subcontractor(s), shall not relieve Contractor of any responsibility or liability for damage or accidents as set forth in the Contract Documents. The bankruptcy, insolvency or denial of liability of or by Contractor's insurance company shall likewise not exonerate or relieve Contractor from liability.

11.534 City reserves the right to review the insurance requirements of this **Article XI** during the effective period of this Contract and to adjust insurance coverage and insurance limits when deemed necessary and prudent by City's Risk Management Division, based upon changes in statutory law, court decisions or the claims history of Contractor and Subcontractors. Contractor agrees to make any reasonable request for deletion, revision or modification of particular policy terms, conditions, limitations or exclusions, except where policy provisions are established by law or regulation binding upon either Party to this Contract or upon the underwriter of any such policy provisions. Upon request by City, Contractor shall exercise reasonable efforts to accomplish such changes in policy coverage.

11.535 No special payments shall be made for any insurance policies that Contractor and Subcontractors are required to carry. Except as provided in **Section 11.5.3.4** herein, all amounts payable regarding the insurance policies required under the Contract Documents are included in the Contract Sum.

11.536 Any insurance policies required under this **Article XI** may be written in combination with any of the other policies, where legally permitted, but none of the specified limits neither may be lowered or otherwise negatively impacted by doing so, nor may any of the requirements or special provisions of this **Article XI** be limited or circumvented by doing so.

ARTICLE XII. INSPECTING, UNCOVERING AND CORRECTING OF WORK

121 INSPECTING WORK. City and Design Consultant shall have authority to reject Work that does not conform to the Contract Documents. Whenever City or Design Consultant considers it necessary or advisable, City and/or Design Consultant shall have authority to require inspection or testing of the Work in accordance with this **Article XII**, whether or not such Work is fabricated, installed or completed.

122 UNCOVERING WORK

12.2.1 If a portion of the Work is covered, concealed and/or obstructed, contrary to City's or Design Consultant's requirements specifically expressed in the Contract Documents, it must be uncovered for City's or Design Consultant's inspection and properly be replaced at Contractor's expense without any change in the Contract Time or Sum.

12.2.2 If a portion of the Work has been covered, concealed and/or obstructed and Design Consultant or City has not inspected the Work prior to its being covered, concealed and/or obstructed, City and Design Consultant retain the right to inspect such Work and, when directed by City, Contractor shall uncover it. If said Work is found to be in accordance with the Contract Documents, the costs for uncovering and replacement shall, by appropriate Change Order, be paid by City. If such Work uncovered is found to not be in accordance with the Contract Documents, Contractor shall pay all costs associated with the uncovering, correction and replacement of the Work, unless the condition found was caused by City or City's separate contractor, in which event City shall be responsible for payment of actual costs incurred by Contractor.

123 CORRECTING WORK

- 12.3.1 Contractor promptly shall correct any Work rejected by City or Design Consultant as failing to conform to the requirements of the Contract Documents, whether inspected before or after Substantial Completion and whether or not fabricated, installed or completed. Contractor shall bear costs of correcting such rejected Work, along with all costs for additional testing, inspections and compensation for Design Consultant's services and expenses made necessary thereby.
- 12.3.2 In addition to Contractor's warranty obligations, if any of the Work is found to be defective or nonconforming with the requirements of the Contract Documents, including, but not limited to these General Conditions, Contractor shall correct it promptly after receipt of written notice from City or Design Consultant to correct unless City previously has given Contractor a written acceptance or waiver of the defect or nonconformity. Contractor's obligation to correct defective or nonconforming Work remains in effect for:
- 12.3.2.1 one (1) year after the date of Substantial Completion of the Work or designated portion of the Work;
- 12.3.2.2 one (1) year after the date for commencement of warranties established by agreement in connection with partial occupancy under **Section 9.8** hereto; or
- 12.3.2.3 the stipulated duration of any applicable special warranty required by the Contract Documents.
- 12.3.3 The one (1) year period, described in **Section 12.3.2.1**, **Section 12.3.2.2** and **Section 12.3.2.3** herein, shall be extended, with respect to portions of the Work first performed after Substantial Completion, by the period of time between Substantial Completion and the actual completion of the Work.
- 12.3.4 The obligations of Contractor under **Sections 3.5 and 3.18** herein and this **Section 12.3** shall survive final acceptance of the Work and termination of this Contract. City shall give notice to Contractor promptly after discovery of a defective or nonconforming condition in the Work. The one (1) year period stated in this **Section 12.3** does not limit the ability of City to require Contractor to correct latent defects or nonconformities in the Work, which defects or nonconformities could not have been discovered through reasonable diligence by City or Design Consultant at the time the Work was performed or at the time of inspection for certification of Substantial Completion or Final Completion. The one (1) year period also does not relieve Contractor from liability for any defects or deficiencies in the Work that may be discovered after the expiration of the one (1) year correction period.
- 12.3.5 Contractor shall remove from the Project Site portions of the Work that are not in accordance with the requirements of the Contract Documents and are neither corrected by Contractor nor accepted by City.
- 12.3.6 If Contractor fails to correct any defective or nonconforming Work within what City deems a reasonable time after City or Design Consultant gives written notice of rejection to Contractor, City may correct the defective or nonconforming Work in accordance with this **Section 12.3**. If Contractor promptly does not proceed with correction of any defective or nonconforming Work within a reasonable time fixed by written notice from City or Design Consultant, City may remove or replace the defective or nonconforming Work and store the salvageable materials or equipment at Contractor's expense. If Contractor does not pay the costs of removal and storage within ten (10) calendar days after written notice by City or Design Consultant, City may, upon ten (10) additional calendar days written notice, sell the materials and equipment at auction or at private sale and shall account to Contractor for the proceeds, after deducting all costs and damages that should have been borne by Contractor to correct the defective work, including all compensation for Design Consultant's services and expenses made necessary as a result of the sale, removal and storage. If the proceeds of sale do not cover the costs that

Contractor should have borne, the Contract Sum shall be reduced by the deficiency. If payments due to Contractor then or thereafter are not sufficient to cover the deficiency, Contractor shall pay the difference to City.

- 12.3.7 Contractor shall bear the cost of correcting destroyed or damaged construction of City or City's separate contractors, whether the construction is completed or partially completed, caused by Contractor's correction or removal of Work that is not in accordance with the requirements of the Contract Documents.
- 12.3.8 Nothing contained in this **Section 12.3** shall be construed to establish a period of limitation with respect to other obligations which Contractor might have under the Contract Documents. The establishment of the one (1) year time period, as described in **Section 12.3.2** relates only to the specific obligation of Contractor to correct the Work and has no relationship to the time within which the obligation to comply with the Contract Documents may be sought to be enforced or to the time within which proceedings may be commenced to establish Contractor's liability with respect to Contractor's obligations other than specifically to correct the Work.
- 12.3.9 Any Work repaired or replaced, pursuant to this **Article XII**, shall be subject to the provisions of **Article XII** to the same extent as Work originally performed or installed.
- 12.4 ACCEPTANCE OF NONCONFORMING WORK.** City may, in City's sole discretion, accept Work that is not in accordance with the requirements of the Contract Documents instead of requiring its removal and correction. Upon that occurrence, the Contract Sum shall be reduced as appropriate and equitable, as solely determined by City. Any adjustment shall be accomplished whether or not final payment has been made.

ARTICLE XIII. COMPLETION OF THE CONTRACT; TERMINATION; TEMPORARY SUSPENSION

- 13.1 FINAL COMPLETION OF CONTRACT.** The Contract shall be considered completed, except as provided in any warranty or maintenance stipulations, bond or by law, when all the Work has been finally completed, a final inspection is made by City and Design Consultant and final acceptance and final payment is made by City.
- 13.2 WARRANTY FULFILLMENT.** Prior to the expiration of the specified warranty period provided for in the Contract Documents, City or Design Consultant shall make a detailed inspection of the Work and shall advise Contractor and may advise Contractor's Surety of the items that require correction. City or Design Consultant shall make a subsequent inspection and, if the corrections have been properly performed, City shall issue a letter of release on the maintenance obligations to Contractor. If, for any reason, Contractor has not made the required corrections before the expiration of the warranty period, the warranty provisions as provided for in the Contract Documents shall remain in effect until the corrections have properly been performed and a letter of release from City to Contractor is issued.

13.3 TERMINATION BY CITY FOR CAUSE

- 13.3.1 Notwithstanding any other provision of these General Conditions, the Work or any portion of the Work may be terminated immediately by City for any good cause after giving seven (7) calendar days advance written notice and an opportunity to cure to Contractor, including but not limited to the following causes:
- 13.3.1.1 Failure or refusal of Contractor to start the Work within ten (10) calendar days after the date

of the written Notice to Proceed is issued by City to Contractor to commence Work.

- 13.3.1.2 A reasonable belief of City or Design Consultant that the progress of the Work being made by Contractor is insufficient to complete the Work within the specified Contract Time.
- 13.3.1.3 Failure or refusal of Contractor to provide sufficient and proper equipment or construction forces properly to execute the Work in a timely manner.
- 13.3.1.4 A reasonable belief Contractor has abandoned the Work.
- 13.3.1.5 A reasonable belief Contractor has become insolvent, bankrupt, or otherwise is financially unable to carry on the Work.
- 13.3.1.6 Failure or refusal on the part of Contractor to observe any material requirements of the Contract Documents or to comply with any written orders given by City or Design Consultant, as provided for in the Contract Documents.
- 13.3.1.7 Failure or refusal of Contractor promptly to correct any defects in materials or workmanship, or defects of any nature, the correction of which has been directed to Contractor in writing by City or Design Consultant.
- 13.3.1.8 A reasonable belief by City collusion exists or has occurred for the purpose of illegally procuring the Contract or a Subcontractor, or that a fraud is being perpetrated on City in connection with the construction of Work under the Contract.
- 13.3.1.9 Repeated and flagrant violation of safe working procedures or other requirements of the Contract.

1332 When the Work or any portion of the Work is terminated for any of the causes itemized in **Section 13.3.1** herein, or for any other cause except termination for convenience pursuant to **Section 13.3.6** herein, Contractor shall, as of the date specified by City, immediately discontinue the Work or portion of the Work as City shall designate, whereupon the Surety shall, within fifteen (15) calendar days after the written Notice of Termination by City For Cause has been served upon Contractor and the Surety or its authorized agents, assume the obligations of Contractor for the Work or that portion of the Work which City has ordered Contractor to discontinue and Surety may:

- 13.3.2.1 perform the Work with forces employed by the surety;
- 13.3.2.2 with the written consent of City, tender a replacement Contractor to take over and perform the Work, in which event the Surety shall be responsible for and pay the amount of any costs required to be incurred or the completion of the Work that are in excess of the amount of funds remaining under the Contract as of the time of the termination; or
- 13.3.2.3 with the written consent of City, tender and pay to City in settlement the amount of money necessary to finish the balance of uncompleted Work under the Contract, correct existing defective or nonconforming work and compensate City for any other loss sustained as a result of Contractor's default.

In the event of Termination by City For Cause involving **Article 13.3.2.1** and/or **Article 13.3.2.2**, the Surety shall assume Contractor's place in all respects and the amount of funds remaining and unpaid under the Contract shall be paid by City for all Work performed by the Surety or the replacement contractor in accordance with the terms of the Contract Documents, subject to any rights of City to

deduct any and all costs, damages (liquidated or actual) City incurred including, but not limited to, any and all additional fees and expenses of Design Consultant and any attorneys' fees City incurs as a result of Contractor's default and subsequent termination.

- 1333** The balance of the Contract Sum remaining at the time of Contractor's default and subsequent termination shall become due and payable to the Surety as the Work progresses, subject to all of the terms, covenants and conditions of the Contract Documents. If the Surety does not, within the time specified in **Section 13.3.2** herein, exercise its obligation to assume the obligations of the Contract, or that portion of the Work which City has ordered Contractor to discontinue, then City shall have the power to complete the Work by contract or otherwise, as City may deem necessary and elect. Contractor agrees that City shall have the right to:
- (1) take possession of or use any or all of the materials, plant, tools, equipment, supplies and property of every kind, to be provided by Contractor for the purpose of the Work; and
 - (2) procure other tools, equipment, labor and materials for the completion of the Work at Contractor's expense; and
 - (3) charge to the account of Contractor the expenses of completion and labor, materials, tools, equipment, and incidental expenses.
- 1334** All expenses incurred by City to complete the Work shall be deducted by City out of the balance of the Contract Sum remaining unpaid to or unearned by Contractor. Contractor and the Surety shall be liable to City for any costs incurred in excess of the balance of the Contract Sum for the completion and correction of the Work, and for any other costs, damages, expenses (including, but not limited to, additional fees of Design Consultant and attorney's fees) and liquidated or actual damages incurred as a result of the termination.
- 1335** City shall not be required to obtain the lowest bid for the Work of completing the Contract, as described in **Section 13.3.3** herein, but the expenses to be deducted from the Contract Sum shall be the actual cost of such Work and the other damages, as provided in **Section 13.3.3** herein. In case City's costs and damages are less than the sum which would have been payable under the Contract if the Work had been completed by Contractor pursuant to the Contract, then City may pay Contractor (or the Surety, in the event of a complete Termination by City For Cause) the difference, provided that Contractor (or the Surety) shall not be entitled to any claim for damages or for loss of anticipated profits. In case such costs for completion and damages shall exceed the amount which would have been payable under the Contract if the Work had been completed by Contractor pursuant to the Contract, then Contractor and its Surety shall pay the amount of the excess to City immediately upon written notice from City to Contractor and/or the Surety for the excess amount owed. When only a particular part of the Work is being carried on by City, by contract or otherwise under the provisions of this Section, Contractor shall continue the remainder of the Work in conformity with the terms of the Contract and in such manner as not to hinder or interfere with the performance of workers employed and provided by City.
- 1336** **TERMINATION FOR CONVENIENCE.** The right to terminate this Contract for the convenience of City (including, but not limited to, non-appropriation of funding) expressly is retained by City. In the event of a termination for convenience by City, City shall, at least ten (10) calendar days in advance, deliver written notice of the termination for convenience to Contractor. Upon Contractor's receipt of such written notice, Contractor immediately shall cease the performance of the Work and shall take reasonable and appropriate action to secure and protect the Work then in place. Contractor shall then be paid by City, in accordance with the terms and provisions of the Contract Documents, an amount not to exceed the actual labor costs incurred, the actual cost of all materials installed and the actual cost of all materials stored at the Project site or away from the Project site, as approved in writing by City but not yet paid for and which cannot be returned, plus applicable authorized overhead, profit, and actual,

reasonable and documented termination costs, if any, paid by Contractor in connection with the Work in place which is completed and in conformance with the Contract Documents up to the date of termination for convenience, less all amounts previously paid for the Work. No amount ever shall be paid to Contractor for lost or anticipated profits on any part of the Work not performed.

13.4 TEMPORARY SUSPENSION OF THE WORK

134.1 The Work or any portion of the Work may temporarily be suspended by City, for a time period not to exceed ninety (90) calendar days, immediately upon written notice to Contractor for any reason, including, but not limited to:

13.4.1.1 the causes described in **Section 13.3.1.1** through **Section 13.3.1.9** herein;

13.4.1.2 under other provisions in the Contract Documents that require or permit temporary suspension of the Work;

13.4.1.3 situations where the Work is threatened by, contributes to or causes an immediate threat to public health, safety, or security; or

13.4.1.4 other unforeseen conditions or circumstances.

134.2 Contractor immediately shall resume the temporarily suspended Work when ordered in writing to do so by City. City shall not, under any circumstances, be liable for any claim of Contractor arising from a temporary suspension due to a cause described in **Section 13.4.1** herein; provided, however, that in the case of a temporary suspension for any of the reasons described under **Section 13.4.1.2** through **Section 13.4.1.4** herein, where Contractor is not a contributing cause of the suspension or where the provision of the Contract Documents in question does not specifically provide that the suspension is at no cost to City, City shall make an equitable adjustment for the following items, provided that a Claim properly is made by Contractor under **Section 4.3** herein:

13.4.2.1 an equitable extension of the Contract Time, not to exceed the actual delay caused by the temporary suspension, as determined by City and Design Consultant;

13.4.2.2 an equitable adjustment to the Contract Sum for the actual, necessary and reasonable costs of properly protecting any Work finished or partially finished during the period of the temporary suspension; provided, however, that no payment of profit and/or authorized overhead shall be allowed on top of these costs; and

13.4.2.3 if it becomes necessary to move equipment from the Project Site and then return it to the Project Site when the Work is ordered to be resumed, an equitable adjustment to the Contract Sum for the actual, necessary and reasonable cost of these moves; provided, however, that no adjustment to the Contract Sum shall be due if said equipment is moved to another Project site of City.

ARTICLE XIV. MISCELLANEOUS PROVISIONS

14.1 GOVERNING LAW; COMPLIANCE WITH LAWS AND REGULATIONS

14.1.1 This Contract shall be governed by the laws and case decisions of the State of Texas, without regard to conflict of law or choice of law principles of Texas or of any other state.

14.12 This Contract is entered into subject to and controlled by the Charter and ordinances of the City of Pflugerville and all applicable laws, rules and regulations of the State of Texas and the Government of the United States of America. Contractor shall, during the performance of the Work, comply with all applicable City of Pflugerville codes and ordinances, as amended, and all applicable State of Texas and Federal laws, rules and regulations, as amended.

14.2 SUCCESSORS AND ASSIGNS. City and Contractor respectively bind themselves, their partners, successors, assigns and legal representatives to the promises, covenants, terms, conditions and obligations contained in the Contract Documents. Contractor shall not assign, transfer or convey its interest or rights in the Contract, in part or as a whole, without the written consent of City. If Contractor attempts to make an assignment, transfer or conveyance without City's written consent, Contractor nevertheless shall remain legally responsible for all obligations under the Contract Documents. City shall not assign any portion of the Contract Sum due or to become due under this Contract without the written consent of Contractor, except where assignment is compelled by court order, other operation of law or the terms of these General Conditions.

14.3 WRITTEN NOTICE. Any notice, payment, statement or demand required or permitted to be given under this Contract by either Party to the other may be effected by personal delivery in writing or by facsimile transmission, email or by mail, postage prepaid, or by overnight delivery to an officer, management level employee or other designated representative of either Party. Mailed or email notices shall be addressed to the Parties at an address designated by each Party, but each Party may change its address by written notice in accordance with this section. Mailed notices shall be deemed received as of three (3) calendar days after mailing.

14.4 RIGHTS AND REMEDIES; NO WAIVER OF RIGHTS BY CITY

14.4.1 The duties and obligations imposed on Contractor by the Contract Documents and the rights and remedies available to City under the Contract Documents shall be in addition to, and not a limitation of, any duties, obligations, rights and remedies otherwise imposed or made available by law.

14.4.2 No action or failure to act by City shall constitute a waiver of a right afforded City under the Contract Documents, nor shall any action or failure to act by City constitute approval of or acquiescence in a breach of the Contract by Contractor, except as may be specifically agreed in writing by Change Order, Amendment or Supplemental Agreement.

14.5 INTEREST. City shall not be liable for interest on any progress or final payment to be made under the Contract Documents, except as may be provided by the applicable provisions of the Prompt Payment Act, Chapter 2251, Texas Government Code, as amended, subject to **Article IX** of these General Conditions.

14.6 INDEPENDENT MATERIALS TESTING AND INSPECTION

In some circumstances, City shall retain, independent of Contractor, the inspection services, the testing of construction materials engineering and the verification testing services necessary for acceptance of the Project by City. The professional services, duties and responsibilities of any independent Consultants shall be described in the agreements between City and those Consultants. The provision of inspection services by City shall be for Quality Assurance and shall not reduce or lessen Contractor's responsibility for the Work or its duty to establish and implement a thorough Quality Control Program to monitor the quality of construction and guard City against defects and deficiencies in the Work, as required herein. Contractor fully and solely is responsible for constructing the Project in strict accordance with the Construction Documents.

14.7 COMPLIANCE WITH CHAPTER 38 OF THE CITY'S CODE OF ORDINANCES.

Contractor acknowledges that this Contract is conditioned upon Contractor's compliance with Chapter 38, Sections 38.01 through 38.07 of the City's Code of Ordinances, all of which are incorporated herein by reference. Contractor hereby certifies that Contractor has fully read and understood the terms and conditions for eligibility to contract with the City pursuant to Chapter 38 of the City's Ordinances and by entering into this Contract hereby certifies that they are in compliance with these requirements.

14.8 VENUE. This Contract is performed in Travis County, Texas, and if legal action is necessary to enforce this Contract, exclusive venue shall lie in Travis County, Texas.

14.9 INDEPENDENT CONTRACTOR. In performing the Work under this Contract, the relationship between City and Contractor is and shall remain an independent contractor. Contractor shall exercise independent judgment in performing the Work and solely is responsible for setting working hours, scheduling and/or prioritizing the Work flow and determining the means and methods of performing the Work, subject only to the requirements of the Contract Documents. No term or provision of this Contract shall be construed as making Contractor an agent, servant or employee of City or making Contractor or any of Contractor's employees, agents or servants eligible for the fringe benefits, such as retirement, insurance and worker's compensation that the City provides to its employees.

14.10 TEXAS GOVERNMENT CODE. The City of Pflugerville may not enter into a contract with a company for goods and services unless the contract contains a written verification from the company that; (i) it does not Boycott Israel; and (ii) will not Boycott Israel during the term of the contract. (Texas Government Code Chapter 2270). By accepting this Contract, Contractor verifies and hereby certifies that it does not Boycott Israel and agrees that during the term of this Contract will not Boycott Israel as that term is defined in the Texas Government Code Section 808.001, as amended.

14.11 GIFTS TO PUBLIC SERVANTS

- 14.11.1 City may terminate this Contract immediately if Contractor has offered, conferred or agreed to confer any benefit on a City of Pflugerville employee or official that the employee or official is prohibited by law from accepting.
- 14.11.2 For purposes of this Article, "benefit" means anything reasonably regarded as pecuniary gain or pecuniary advantage, including benefit to any other person in whose welfare the beneficiary has a direct or substantial interest, but does not include a contribution or expenditure made and reported in accordance with law.
- 14.11.3 Notwithstanding any other legal remedies, City may require Contractor to remove any employee of Contractor, a Subcontractor or any employee of a Subcontractor from the Project who has violated the restrictions of this **Article XIV** or any similar State or Federal law and City may obtain reimbursement for any expenditures made to Contractor as a result of an improper offer, an agreement to confer or the conferring of a benefit to a City of Pflugerville employee or official.

ARTICLE XV. AUDIT

15.1 RIGHT TO AUDIT CONTRACTOR'S RECORDS. By execution of the Contract, Contractor grants City the right to audit, examine, inspect and/or copy, at City's election at all reasonable times during the term of this Contract and for a period of four (4) years following the completion or termination of the Work, all of Contractor's written and electronically stored records and billings relating to the performance of the Work under the Contract Documents. The audit, examination or

inspection may be performed by a City designee, which may include its internal auditors or an outside representative engaged by City. Contractor agrees to retain its records for a minimum of four (4) years following termination of the Contract, unless there is an ongoing dispute under the Contract, then, such retention period shall extend until final resolution of the dispute, with full access allowed to authorized representatives of City upon request, for purposes of evaluating compliance with this and other provisions of the Contract.

- 15.1.1 As used in these General Conditions, "Contractor written and electronically stored records" or "Contractor's records" shall include any and all information, materials and data of every kind and character generated as a result of the work under this Contract. Example of Contractor written and electronically stores records include, but are not limited to: accounting data and reports, billings, books, general ledgers, cost ledgers, invoices, production sheets, documents, correspondences, meeting notes, subscriptions, agreements, purchase orders, leases, contracts, commitments, arrangements, notes, daily diaries, reports, drawings, receipts, vouchers, memoranda, time sheets, payroll records, policies, procedures, Subcontractor agreements, Supplier agreements, rental equipment proposals, federal and state tax filings for any issue in question, along with any and all other agreements, sources of information and matters that may, in City's sole judgment, have any bearing on or pertain to any matters, rights, duties or obligations under or covered by any Contract Documents.
- 15.1.2 City agrees that it shall exercise the right to audit, examine or inspect Contractor's records only during regular business hours. Contractor agrees to allow City and/or City's designee access to all of the Contractor's Records, Contractor's facilities and current or former employees of Contractor, deemed necessary by City or its designee(s), to perform such audit, inspection or examination. Contractor also agrees to provide adequate and appropriate work space necessary for City or its designees to conduct such audits, inspections or examinations.
- 15.1.3 Contractor shall include this **Article XV** in any Subcontractor, supplier or vendor contract, for the benefit of the City.

ARTICLE XVI. ATTORNEY FEES

The Parties hereto expressly agree, in the event of litigation, the prevailing Party shall be entitled to payment of reasonable attorneys' fees and costs as may be recoverable, pursuant to the Texas Civil Practice and Remedies Code Chapter 38, Texas Local Government Code §271.153, the Prompt Payment Act, common law or any other provision of applicable federal, state or local law for payment of attorney's fees.

End of General Conditions. The remainder of this page left blank intentionally.

**SPECIAL CONDITIONS FOR CITY OF PFLUGERVILLE CIP CONSTRUCTION
CONTRACTS**

[Insert as Applicable]

(Remainder of this page intentionally left blank)

"General Decision Number: TX20240007 01/05/2024

Superseded General Decision Number: TX20230007

State: Texas

Construction Types: Heavy and Highway

Counties: Atascosa, Bandera, Bastrop, Bell, Bexar, Brazos, Burleson, Caldwell, Comal, Coryell, Guadalupe, Hays, Kendall, Lampasas, McLennan, Medina, Robertson, Travis, Williamson and Wilson Counties in Texas.

HEAVY (excluding tunnels and dams, not to be used for work on Sewage or Water Treatment Plants or Lift / Pump Stations in Bell, Coryell, McClennon and Williamson Counties) and HIGHWAY Construction Projects

Note: Contracts subject to the Davis-Bacon Act are generally required to pay at least the applicable minimum wage rate required under Executive Order 14026 or Executive Order 13658. Please note that these Executive Orders apply to covered contracts entered into by the federal government that are subject to the Davis-Bacon Act itself, but do not apply to contracts subject only to the Davis-Bacon Related Acts, including those set forth at 29 CFR 5.1(a)(1).

If the contract is entered into on or after January 30, 2022, or the contract is renewed or extended (e.g., an option is exercised) on or after January 30, 2022:	Executive Order 14026 generally applies to the contract. The contractor must pay all covered workers at least \$17.20 per hour (or the applicable wage rate listed on this wage determination, if it is higher) for all hours spent performing on the contract in 2024.
-------------------------------------------------------------------------------------------------------------------------------------------------------------------	-------------------------------------------------------------------------------------------------------------------------------------------------------------------------------------------------------------------------------------------------------------------------

If the contract was awarded on or between January 1, 2015 and January 29, 2022, and the contract is not renewed or extended on or after January 30, 2022:	Executive Order 13658 generally applies to the contract. The contractor must pay all covered workers at least \$12.90 per hour (or the applicable wage rate listed on this wage determination, if it is higher) for all hours spent performing on that contract in 2024.
-----------------------------------------------------------------------------------------------------------------------------------------------------------	--------------------------------------------------------------------------------------------------------------------------------------------------------------------------------------------------------------------------------------------------------------------------

The applicable Executive Order minimum wage rate will be adjusted annually. If this contract is covered by one of the Executive Orders and a classification considered necessary for performance of work on the contract does not appear on this wage determination, the contractor must still submit a conformance request.

Additional information on contractor requirements and worker protections under the Executive Orders is available at <http://www.dol.gov/whd/govcontracts>.

Modification Number Publication Date
0 01/05/2024

SUTX2011-006 08/03/2011

Rates Fringes

CEMENT MASON/CONCRETE
FINISHER (Paving and
Structures). \$ 12.56 **

ELECTRICIAN. \$ 26.35

FORM BUILDER/FORM SETTER
Paving & Curb. \$ 12.94 **
Structures. \$ 12.87 **

LABORER
Asphalt Raker. \$ 12.12 **
Flagger..... \$ 9.45 **
Laborer, Common. \$ 10.50 **
Laborer, Utility. \$ 12.27 **
Pipelayer. \$ 12.79 **
Work Zone Barricade
Servicer. \$ 11.85 **

PAINTER (Structures). \$ 18.34

POWER EQUIPMENT OPERATOR:
Agricultural Tractor. \$ 12.69 **
Asphalt Distributor..... \$ 15.55 **
Asphalt Paving Machine. \$ 14.36 **
Boom Truck. \$ 18.36
Broom or Sweeper. \$ 11.04 **
Concrete Pavement
Finishing Machine. \$ 15.48 **
Crane, Hydraulic 80 tons
or less. \$ 18.36
Crane, Lattice Boom 80
tons or less. \$ 15.87 **

Crane, Lattice Boom over
80 tons.\$ 19.38
Crawler Tractor.....\$ 15.67 **
Directional Drilling
Locator..... \$ 11.67 **
Directional Drilling
Operator. \$ 17.24
Excavator 50,000 lbs or
Less. \$ 12.88 **
Excavator over 50,000 lbs. ..\$ 17.71
Foundation Drill, Truck
Mounted..... \$ 16.93 **
Front End Loader, 3 CY or
Less. \$ 13.04 **
Front End Loader, Over 3 CY.\$ 13.21 **
Loader/Backhoe. \$ 14.12 **
Mechanic.....\$ 17.10 **
Milling Machine.\$ 14.18 **
Motor Grader, Fine Grade. ..\$ 18.51
Motor Grader, Rough.....\$ 14.63 **
Pavement Marking Machine. .. \$ 19.17
Reclaimer/Pulverizer.\$ 12.88 **
Roller, Asphalt. \$ 12.78 **
Roller, Other. \$ 10.50 **
Scraper. \$ 12.27 **
Spreader Box.....\$ 14.04 **
Trenching Machine, Heavy. ..\$ 18.48

Servicer. \$ 14.51 **

Steel Worker
Reinforcing. \$ 14.00 **
Structural.....\$ 19.29

TRAFFIC SIGNALIZATION:

Traffic Signal Installation
Traffic Signal/Light Pole
Worker. \$ 16.00 **

TRUCK DRIVER

Lowboy-Float.\$ 15.66 **
Off Road Hauler.....\$ 11.88 **
Single Axle. \$ 11.79 **
Single or Tandem Axle Dump
Truck..... \$ 11.68 **
Tandem Axle Tractor w/Semi
Trailer.....\$ 12.81 **

WELDER.....\$ 15.97 **

WELDERS - Receive rate prescribed for craft performing
operation to which welding is incidental.

****** Workers in this classification may be entitled to a higher minimum wage under Executive Order 14026 (\$17.20) or 13658 (\$12.90). Please see the Note at the top of the wage determination for more information. Please also note that the minimum wage requirements of Executive Order 14026 are not currently being enforced as to any contract or subcontract to which the states of Texas, Louisiana, or Mississippi, including their agencies, are a party.

Note: Executive Order (EO) 13706, Establishing Paid Sick Leave for Federal Contractors applies to all contracts subject to the Davis-Bacon Act for which the contract is awarded (and any solicitation was issued) on or after January 1, 2017. If this contract is covered by the EO, the contractor must provide employees with 1 hour of paid sick leave for every 30 hours they work, up to 56 hours of paid sick leave each year. Employees must be permitted to use paid sick leave for their own illness, injury or other health-related needs, including preventive care; to assist a family member (or person who is like family to the employee) who is ill, injured, or has other health-related needs, including preventive care; or for reasons resulting from, or to assist a family member (or person who is like family to the employee) who is a victim of, domestic violence, sexual assault, or stalking. Additional information on contractor requirements and worker protections under the EO is available at <https://www.dol.gov/agencies/whd/government-contracts>.

Unlisted classifications needed for work not included within the scope of the classifications listed may be added after award only as provided in the labor standards contract clauses (29CFR 5.5 (a) (1) (iii)).

The body of each wage determination lists the classification and wage rates that have been found to be prevailing for the cited type(s) of construction in the area covered by the wage determination. The classifications are listed in alphabetical order of ""identifiers"" that indicate whether the particular rate is a union rate (current union negotiated rate for local), a survey rate (weighted average rate) or a union average rate (weighted union average rate).

Union Rate Identifiers

A four letter classification abbreviation identifier enclosed in dotted lines beginning with characters other than ""SU"" or ""UAVG"" denotes that the union classification and rate were prevailing for that classification in the survey. Example:

PLUM0198-005 07/01/2014. PLUM is an abbreviation identifier of the union which prevailed in the survey for this classification, which in this example would be Plumbers. 0198 indicates the local union number or district council number where applicable, i.e., Plumbers Local 0198. The next number, 005 in the example, is an internal number used in processing the wage determination. 07/01/2014 is the effective date of the most current negotiated rate, which in this example is July 1, 2014.

Union prevailing wage rates are updated to reflect all rate changes in the collective bargaining agreement (CBA) governing this classification and rate.

Survey Rate Identifiers

Classifications listed under the ""SU"" identifier indicate that no one rate prevailed for this classification in the survey and the published rate is derived by computing a weighted average rate based on all the rates reported in the survey for that classification. As this weighted average rate includes all rates reported in the survey, it may include both union and non-union rates. Example: SULA2012-007 5/13/2014. SU indicates the rates are survey rates based on a weighted average calculation of rates and are not majority rates. LA indicates the State of Louisiana. 2012 is the year of survey on which these classifications and rates are based. The next number, 007 in the example, is an internal number used in producing the wage determination. 5/13/2014 indicates the survey completion date for the classifications and rates under that identifier.

Survey wage rates are not updated and remain in effect until a new survey is conducted.

Union Average Rate Identifiers

Classification(s) listed under the UAVG identifier indicate that no single majority rate prevailed for those classifications; however, 100% of the data reported for the classifications was union data. EXAMPLE: UAVG-OH-0010 08/29/2014. UAVG indicates that the rate is a weighted union average rate. OH indicates the state. The next number, 0010 in the example, is an internal number used in producing the wage determination. 08/29/2014 indicates the survey completion date for the classifications and rates under that identifier.

A UAVG rate will be updated once a year, usually in January of each year, to reflect a weighted average of the current negotiated/CBA rate of the union locals from which the rate is based.

WAGE DETERMINATION APPEALS PROCESS

1.) Has there been an initial decision in the matter? This can be:

- * an existing published wage determination
- * a survey underlying a wage determination
- * a Wage and Hour Division letter setting forth a position on a wage determination matter
- * a conformance (additional classification and rate) ruling

On survey related matters, initial contact, including requests for summaries of surveys, should be with the Wage and Hour National Office because National Office has responsibility for the Davis-Bacon survey program. If the response from this initial contact is not satisfactory, then the process described in 2.) and 3.) should be followed.

With regard to any other matter not yet ripe for the formal process described here, initial contact should be with the Branch of Construction Wage Determinations. Write to:

Branch of Construction Wage Determinations
Wage and Hour Division
U.S. Department of Labor
200 Constitution Avenue, N.W.
Washington, DC 20210

2.) If the answer to the question in 1.) is yes, then an interested party (those affected by the action) can request review and reconsideration from the Wage and Hour Administrator (See 29 CFR Part 1.8 and 29 CFR Part 7). Write to:

Wage and Hour Administrator
U.S. Department of Labor
200 Constitution Avenue, N.W.
Washington, DC 20210

The request should be accompanied by a full statement of the interested party's position and by any information (wage payment data, project description, area practice material, etc.) that the requestor considers relevant to the issue.

3.) If the decision of the Administrator is not favorable, an interested party may appeal directly to the Administrative Review Board (formerly the Wage Appeals Board). Write to:

Administrative Review Board
U.S. Department of Labor
200 Constitution Avenue, N.W.
Washington, DC 20210

4.) All decisions by the Administrative Review Board are final.

END OF GENERAL DECISION"

CITY OF PLUGERVILLE
Purchasing Services
Historically Underutilized Business

The City of Pflugerville is committed to assuring that all businesses are given prompt, courteous, and equal opportunity to provide goods and services to the City. To achieve this goal, the City Council requests the minority women owned status of each vendor on the City vendor list.

Definition: A Historically Underutilized Business (HUB) means a business concern owned and controlled by socially and economically disadvantaged individuals. This means any business concern that (a) is at least 51% owned by one or more socially and economically disadvantaged individuals; or in the case of publicly owned businesses, at least 51% of the stock which is owned by one or more socially or economically disadvantaged individuals; and (b) whose management and daily operations are controlled by one or more other socially and economically disadvantaged individuals who own it. The groups included in this program are Black Americans, Hispanic Americans, Women, Asian Pacific Americans, Service-Disabled Veterans, and Native Americans

Certification: Bidder declares a minority and/or women owned business status:

YES NO

If yes, check one of the blocks (indicate male or female):

Black M/F ____; Hispanic M/F ; Woman ; Asian M/F ____;

Native American M/F ____; Service Disabled Veteran of 20% or more M/F ____.

HUB certified YES NO

Visit <https://texashub.gob2g.com/> to become a certified HUB

COMPANY NAME: SA Smart Solutions, LLC

ADDRESS: 8610 N New Braunfels Ave Suite 302

CITY/STATE: San Antonio, TX

EMAIL/PHONE: satxsmartsolutions@gmail.com, andrew@satxsmart.com / 210.628.9024

PRODUCT/SERVICE: Electrical Contractor

AUTHORIZED SIGNATURE: _____

TECHNICAL SPECIFICATIONS

SECTION CIP1 – DEFINITION OF TERMS

CIP1.01

DEFINITIONS

- A. Wherever in these specifications or in other contract documents, the following terms or pronouns in place of them are used, the intent and meaning shall be interpreted as follows:
1. CITY - The City of Pflugerville, party of the First Part.
 2. COUNCIL - The Pflugerville City Council.
 3. COUNTY - A political Subdivision of the State.
 4. ENGINEER- Representative of the City and/or “Design Consultant” as provided in the General Conditions for Pflugerville Capital Improvement Projects.
*ENGINEER - Representative of the Contractor or the Developer.
 5. INSPECTOR - The authorized representative of the City assigned to inspect any or all parts of the work and the materials to be used therein.
 6. CONTRACTOR - The individual, firm or corporation or any combination thereof, Party of the Second Part, with which the contract is made by the City, Developer or Public Cooperation.
 7. SUPERINTENDENT - The representative of the Contractor authorized to receive and fulfill instructions from the Engineer or representative of the City, and who shall supervise and direct the construction.
 8. PAVEMENT DESIGN MANUAL - Texas Department of Transportation manual outlining procedure to be followed in the design and control of asphaltic concrete and portland cement concrete mixes for structures and pavements.
 9. MANUAL OF TESTING PROCEDURES - Texas Department of Transportation Materials and Tests Division manual outlining testing methods and procedures.
 10. PLANS - The drawings approved by the City, or true reproductions thereof, which show the location, character, dimensions, and details of the work and which are a part of the contract. Plans and specifications to be prepared by a Professional Engineer registered in the State of Texas.
 11. SPECIFICATIONS - The directions, provisions and requirements contained herein or in the Special Provisions, supplemented by such “Special Provisions or Standards” as may be issued or made pertaining to the method and manner or performing the work or qualities of materials to be furnished. Where the phrases “or directed by the City”, “ordered by the City”, or “to the satisfaction of the City” occur, it is to be understood that the directions, orders, or instructions of which they relate are within the limitations of, and authorized by the contract. “Special Provisions” will cover work pertaining to a particular project included in the proposal but not covered by the specifications. Where reference is made to specifications of ASTM, AWWA, AASHTO or Bulletins and Manuals of the Texas Department of Transportation it shall be construed to mean the latest standard or tentative standard in effect on the date of the proposal.
 12. RIGHT OF WAY - The land provided for a highway or street, owned by the City of Pflugerville or the municipality in which the highway or street is in.
 13. ROADWAY - The portion of the highway or street within the limits of construction.
 14. ROADBED - The graded portion of the roadway between the intersection of top and side slopes upon which the base course, surface course, shoulders and median are constructed.
 15. SUBGRADE - That portion of the roadbed upon which the subbase, base, or pavement structure is to be placed.

16. BRIDGES - Structures of over 20-foot span measured from face to face of abutments, or in case of copings, from face to face of copings, and multiple span structures of over 20-foot length, measured between inside of end walls along the centerline of the roadbed.
17. CULVERTS - All drainage structures not defined as bridges.
18. TEMPORARY STRUCTURES - All temporary bridges and structures required to maintain traffic during the construction of the work.
19. SUBSTRUCTURE - That part of the structure below the bridge seats or below the springing lines of arches. Parapets, back walls and wing walls of abutments shall be considered as parts of the substructure.
20. SUPERSTRUCTURE - The part of the structure above the bridge seats or above the springing lines of arches.
21. THE WORK - The work shall include the furnishing of all labor, materials, equipment, and other incidentals necessary or convenient to the successful completion of the project and the carrying out of all the duties and obligations imposed by the contract; or, if applicable, the Work as defined in the General Conditions for Pflugerville Capital Improvement Projects.
22. PROJECT - The specific section or sections of the highway or street together with all appurtenances and construction to be performed thereon under the contract; or, if applicable, the Project as defined in the General Conditions for Pflugerville Capital Improvement Projects.
23. ASTM - American Society for Testing Materials.
24. AASHTO - American Association of State Highway and Transportation Officials.
25. ANSI - American National Standards Institute.
26. API - American Petroleum Institute.
27. UL - Underwriters Laboratory, Inc.
28. SCREENS AND SIEVES - As defined by the ASTM.
29. HIGHWAY, STREET OR ROAD - A general term denoting a public way for purposes of vehicular travel, including the entire area within the right of way. Recommended usage in urban areas-highway or road.
30. ARTERIAL HIGHWAY OR STREET - A general term denoting a highway or street primarily for through traffic, usually on a continuous route.
31. MAJOR STREET OR MAJOR HIGHWAY - An arterial highway or street with intersections at grade and direct access to abutting property, and on which geometric design and traffic control measures are used to expedite the safe movement of through traffic.
32. THROUGH STREET OR THROUGH HIGHWAY - Every highway, street, or portion thereof at the entrance to which vehicular traffic from intersecting highways or streets is required by law to stop before entering or crossing the same and when stop signs are erected.
33. LOCAL STREET OR LOCAL ROAD - A street or road primarily for access to residence, business, or other abutting property.

END OF SECTION

TECHNICAL SPECIFICATIONS

SECTION CIP2 - ABBREVIATIONS

CIP2.01

SCOPE

A. Whenever in these Contract Documents or Specifications the following abbreviations are used, the intent and meaning shall be interpreted as follows:

1. AA Aluminum Association
2. AAMA Architectural Aluminum Manufacturers' Association
3. AASHTO American Association of State Highway and Transportation Officials
4. ACI American Concrete Institute
5. AFBMA Anti-Friction Bearing Manufacturers' Association
6. AGA American Gas Association
7. AGMA American Gear Manufacturers' Association
8. AISC American Institute of Steel Construction
9. AISI American Iron and Steel Institute
10. AITC American Institute of Timber Construction
11. AMCA Air Moving and Conditioning Association
12. ANSI American National Standards Institute
13. APA American Plywood Association
14. API American Petroleum Institute
15. AREA American Railway Engineering Association
16. ASAE American Society of Agricultural Engineers
17. ASCE American Society of Civil Engineers
18. ASHRAE American Society of Heating, Refrigerating and Air-Conditioning Engineers, Inc.
19. ASME American Society of Mechanical Engineers
20. ASTM American Society of Testing and Materials
21. AWI Architectural Woodwork Institute
22. AWWA American Wood Preservers' Association
23. AWPB American Wood Preservers' Bureau
24. AWS American Welding Society
25. AWWA American Water Works Association
26. BHMA Builders' Hardware Manufacturers' Association
27. CBMA Certified Ballast Manufacturers' Association
28. CDA Copper Development Association
29. CISPI Cast Iron Soil Pipe Institute
30. CMAA Crane Manufacturers' Association of America
31. CRSI Concrete Reinforcing Steel Institute
32. Fed. Spec. Federal Specifications

33.	HI	Hydraulic Institute
34.	HMI	Hoist Manufacturers' Institute
35.	ICBO	International Conference of Building Officials
36.	IEEE	Institute of Electrical and Electronics Engineers, Inc.
37.	IPCEA	Insulated Power Cable Engineer's Association
38.	MMA	Monorail Manufacturers' Association
39.	NACE	National Association of Coatings Engineers
40.	NBMA	National Builders' Hardware Association
41.	NEC	National Electrical Code
42.	NEMA	National Electrical Manufacturers' Association
43.	NESC	National Electric Safety Code
44.	NFPA	National Fire Protection Association
45.	NLMA	National Lumber Manufacturers' Association
46.	NWMA	National Woodwork Manufacturers' Association
47.	OECI	Overhead Electrical Crane Institute
48.	OSHA	Occupational Safety and Health Act (both Federal & State)
49.	PS	Product Standards Sections - U.S. Department of Commerce
50.	RMA	Rubber Manufacturers' Association
51.	SAE	Society of Automotive Engineers
52.	SSPC	Steel Structures Painting Council
53.	TCA	Tile Council of America
54.	TxDOT	Texas Department of Transportation
55.	TEMA	Tubular Exchanger Manufacturers' Association
56.	UBC	Uniform Building Code
57.	UL	Underwriter's Laboratories, Inc.
58.	WWPA	Western Wood Products Association

END OF SECTION

TECHNICAL SPECIFICATIONS

SECTION CIP3 – SUMMARY OF WORK

*** For Projects Contracted by the City of Pflugerville for Capital Improvement Projects ***

CIP3.01 SCOPE OF WORK

- A. This specification covers the requirements for constructing Historic Elevated Water Storage Tank Rehabilitation as shown on the construction Plans and specified herein.
- B. The Work is located within the City of Pflugerville as shown on the Location Map included in the Plans.
- C. The Work includes, but is not necessarily limited to, the following:
 - 1. Procurement and installation of external lighting fixtures as specified.

CIP3.02 WORK SEQUENCE

- A. Perform work in sequence as agreed upon at the pre-construction conference.

CIP3.03 PROGRESS OF THE WORK

- A. The Work shall be started within 10 days following the effective date of the Notice to Proceed, and the Work shall be executed with such progress as may be required to prevent any delay to the general completion of the project. The Work shall be executed at such times and in or on such parts of the project, and with such personnel, materials, and equipment to assure completion of the Work in the time established by the Agreement.
- B. If the Contractor for his convenience and at his own expense, should desire to carry on his work at night or outside regular hours, he shall submit a written approval request to the City and he shall allow ample time for satisfactory arrangements to be made for inspecting the work in progress. The Contractor shall pay the expenses for extra inspection required for work outside regular hours. Normal working hours for this purpose are Monday through Friday, 7:00 a.m. to 6:00 p.m. The Contractor shall light the different parts of the Project as required to comply with all applicable Federal and State regulations and with all applicable requirements of the City of Pflugerville.

CIP3.04 CONSTRUCTION SCHEDULE

- A. The Contractor shall, in accordance with the General Conditions, provide and submit to the City for approval, the Schedule for the project. A complete updated schedule shall be submitted with monthly pay requests. The Schedule shall account for all the work of the Contractor and his Subcontractors and suppliers. The Schedule shall fully comply with the requirements of the General Conditions.
- B. While the Contractor bears full responsibility for scheduling all phases and stages of the Work to ensure its successful prosecution and completion within the time specified in accordance with all provisions of these Specifications, the Contractor is specifically required to complete fully or complete such stages of work to enable his Subcontractors and suppliers to complete their work within the respective times specified.
- C. If the City determines that operations are falling behind schedule at any time during the construction period, the City may require the Contractor to add to his plant, equipment and/or construction forces, including increases in working hours, in such quantities as are required to bring operations back on schedule, in accordance with the General Conditions. Upon receipt of written communication from the City requiring such addition, the Contractor shall furnish same at no additional cost to the City.

PRECONSTRUCTION CONFERENCE

- A. A pre-construction conference shall be held as soon as possible after issuance of Notice of Award of Contract and before Work is started. The conference will be held at a location selected by the City. The conference will be attended by:
1. Contractor's Office Representative.
 2. Contractor's General Superintendent.
 3. Any subcontractors' or suppliers' representatives whom the Contractor may desire to invite or the City may request.
 4. Design Consultant's Representatives.
 5. City's Representatives.
 6. Such other individuals that the City may invite.
- B. Format may include, but not be limited to, the following subjects and others provided in the Contract Documents:
1. Verification of required bonds and insurance certifications.
 2. Liquidated damages.
 3. Shop drawing submittal and approval procedure.
 4. Chain of command, direction of correspondence, and coordinating responsibility between Contractors.
 5. Schedule of periodic job meetings for all involved.
 6. Introduction of the key project personnel.
 7. Equal opportunity requirements.
 8. Laboratory testing of material requirements.
 9. Inventory of material stored on site provisions.
 10. Progress estimate and payment procedure.
 11. Discussion of Contractor's Safety program.
 12. Scheduled plan for work requiring interruption of existing operations.
 13. Review of the construction Plans and Specifications.
 14. Discussion of Contractor's storage facilities for the Project.
- C. The City's Representative will preside at the conference, prepare the minutes of the meeting and distribute copies of same to all participants who so request by fully completing the attendance form to be circulated at the beginning of the conference.

CONSTRUCTION MEETINGS

- A. Periodic Construction meetings shall be held at intervals designated by the City, generally weekly to review the progress at the project, submittals, upcoming activities, pay requests, etc. The Contractor is expected to have at least the project Superintendent present for all meetings. Attendance at the meetings

shall not be directly paid for but shall be considered subsidiary to the items of the Contract.

- B. In the event the Contractor is 30 minutes late or more or fails to attend a Construction meeting without 48 hours prior notice, the Contractor shall be billed the time for the Design Consultant(s) to represent the City at \$150.00 per hour up to one (1) hour.

CIP3.07

COORDINATION WITH CITY'S OPERATIONS AND EXISTING FACILITIES

- A. Several parts of the proposed Work under this Contract may connect with or into existing facilities. The Contractor shall plan carefully the schedule of that portion of the Work which will affect the existing facilities. Such plans and schedules shall be subject to the approval of the City of Pflugerville.
- B. Work which requires shutdown or in any way impedes the operations of existing facilities shall be closely coordinated with the City of Pflugerville. A minimum of 48 hours written notice shall be given to the City of Pflugerville.
- C. Immediately after the award of a Contract for this Project, the Contractor shall outline and submit a scheduled plan for installation of the work, which requires interruption of operations.

CIP3.08

CONTRACTOR'S USE OF PREMISES

- A. Contractor shall limit the use of the premises for his/her work and coordinate use of the premises with the City to allow for:
 - 1. Work by other Contractors.
 - 2. Public use.
- B. Contractor shall assume full responsibility for security of all materials and equipment stored on the site.
- C. If directed by the City, move any stored items, which interfere with operations of the City, other contractors, or the public.
- D. Obtain and pay for use of additional storage or work areas at no additional cost to the City if needed to perform the Work.
- E. Contractor shall submit to the City for approval a plan of operations, designating proposed areas of the property to be used for his operations, material storage, equipment storage, employee's parking, offices and shops. The area shall affect minimal interference with the present operations.
- F. Any damage to existing facilities, including contamination, which may be caused by Contractor's personnel, callers, visitors, materials or equipment, shall be repaired or corrected at the sole expense of the Contractor.
- G. Any fence that is damaged or removed by the Contractor will be replaced at the Contractor's expense in like kind, and to the satisfaction of the City.

END OF SECTION

TECHNICAL SPECIFICATIONS

SECTION CIP4 – SITE CONDITIONS AND USE

CIP4.01 SCOPE OF WORK

- A. This specification covers the requirements for investigation and verification of site conditions for the Project, and also provides requirements for Site usage.

CIP4.02 SUBSURFACE INFORMATION

- A. No subsurface investigations have been made by the City unless otherwise indicated in the Contract Documents and being subject to the same. The Bidder / Contractor shall be responsible for any subsurface explorations and tests deemed necessary.
- B. No test borings have been made by the City to indicate subsurface materials unless otherwise indicated in the Contract Documents and being subject to the same.

CIP4.03 SITE INVESTIGATION AND REPRESENTATION

- A. The Bidder / Contractor acknowledges that Contractor has satisfied itself as to the nature and location of the Work; the general and local conditions, particularly those bearing upon availability of transportation, disposal, handling and storage of materials, availability of labor, water, electric power, roads, and uncertainties of weather, river/stream stages, or similar physical conditions at the site; the conformation and conditions of the ground; the character of equipment and facilities needed preliminary to and during the prosecution of the Work and all other matters which can in any way affect the Work or the cost thereof under this Contract.
- B. The Contractor further acknowledges that Contractor has satisfied itself as to the character, quality, and quantity of surface and subsurface materials to be encountered from inspecting the site and from evaluating information derived from exploratory work, if any, that has been done by the City as presented in the geotechnical report, as well as from information presented herein as a part of these Contract Documents. Any failure by the Contractor to acquaint itself with all the available information will not relieve Contractor from responsibility for properly estimating the difficulty or cost of successfully performing the work. Neither the City nor the Engineer (which includes Design Consultant throughout these Technical Specifications if included within a City Capital Improvement Project Contract) assume responsibility for any conclusion or interpretation made by the Contractor on the basis of the information made available by the City or the Engineer, nor accept responsibility occasioned by any information so provided in excess of that established by the Contract Documents, if applicable.
- C. Existing ground profiles shown on the Plans were plotted from field surveys.

CIP4.04 RESPONSIBILITY FOR UTILITY PROPERTIES AND SERVICE

- A. Known utilities and structures adjacent to or encountered in the work are shown on the Plans. The locations shown are taken from existing records and the best information available from existing plans; however, it is expected that there may be some discrepancies and omissions in the locations and quantities of utilities and structures shown. Those shown are for the convenience of the Contractor only, and no responsibility is assumed by either the City or the Engineer for their accuracy or completeness.
- B. Neither the City nor its officers or agents shall be responsible to the Contractor for damages as a result of the Contractor's failure to protect utilities encountered in the work.
- C. The Contractor shall at all times provide unobstructed access to fire hydrants and structures as per Fire Code, underground conduit, manholes, and water or gas valve boxes.

- D. Where the Contractor's operations could cause damage which might result in considerable expense, loss, or inconvenience when his operations are adjacent to or near railway, telegraph, telephone, television, power, oil, gas, water, sewer, irrigation, or other systems, no operations shall be commenced until the Contractor has made all arrangements necessary for the protection of these utilities and services.
- E. The Contractor shall notify all utility offices that are affected by the construction operation at least 15 days in advance of commencing construction operations. The Contractor shall not expose any utility without first obtaining permission from the affected agency. Once permission has been granted, locate and, if necessary, expose and provide temporary support for all existing underground utilities in advance of operations.
- F. The Contractor shall be solely and directly responsible to the City and operators of such utility properties for any damage, injury, expense, loss, inconvenience, delay, suits, actions, or claims of any character brought because of any injuries or damage that may result from the construction operations under this Contract.
- G. In the event of interruption to domestic water, sewer, storm drain, or other utility services as a result of accidental breakage due to construction operations, the Contractor shall promptly notify the proper authority and cooperate with said authority in restoration of service as promptly as possible and bear all costs of repair.
- H. The Contractor shall replace, at Contractor's own expense, any and all other existing utilities or structures removed or damaged during construction, unless otherwise provided for in these Contract Documents.
- I. Where existing utility lines or structures are so located as to physically conflict with permanent structures to be constructed under this Contract, the conflicting utility line or structure shall be permanently relocated.
- J. The Contractor shall give immediate notice to the Engineer, the City and the owner of the utility (where applicable) when a physical conflict is determined to exist.
 - 1. Contractor will not be charged contract time for delays caused by unanticipated conflicts.
 - 2. Contractor shall not charge the City of Pflugerville for lost time or down time for unanticipated conflicts.
- K. Where existing utility lines or structures are so located as to interfere with the Contractor's prosecution of the work, but do not physically conflict with completed manholes or other permanent structures to be constructed under this Contract, any modification, alteration, or relocation of interfering utility, either permanent or temporary, shall be accomplished at the expense of the Contractor.

CIP4.05

INTERFERING STRUCTURES

- A. Take necessary precautions to prevent damage to existing structures whether on the surface, aboveground, or underground. An attempt has been made to show major structures on the Plans. While the information has been compiled from the best available sources, its completeness and accuracy cannot be guaranteed, and it is presented as a guide to avoid known possible difficulties.
- B. Protect existing structures from damage, whether or not they lie within the right-of-way or the limits of the easements obtained by the City. Where existing structures must be removed to properly carry out the work, or are damaged during the Work, they shall be restored at the Contractor's own expense to at least their original condition and to the satisfaction of the Engineer.
- C. The Contractor may, with the approval of the Engineer and without additional compensation, remove and replace in a condition as good as or better than original, any small interfering structures such as fences and signposts that interfere with the Contractor's operations.

CIP4.06

FIELD RELOCATION

- A. During the progress of the Work, minor relocations of the Work may be necessary. Such relocations shall be made only by direction of the Engineer or the City. If existing structures are encountered that will prevent construction as shown, notify the Engineer before continuing with the Work in order that the Engineer may make such field revisions as necessary to avoid conflict with the existing structures. If the Contractor fails to notify the Engineer when an existing structure is encountered and proceeds with the Work despite this interference, he shall be responsible for any damage that may occur.

CIP4.07

LAND MONUMENTS

- A. The Contractor shall preserve or replace any existing Federal, State, County, City, and private land monuments encountered.
- B. Any damaged or destroyed monuments shall be replaced at the sole expense of the Contractor as designated by the City.

CIP4.08

USE OF SITE

- A. Contractor shall confine construction equipment, the storage of materials and equipment and the operations of workers to areas permitted by law, ordinances, permits or the requirements of the Contract Documents and shall not unreasonably encumber the premises with construction equipment or other materials or equipment.
- B. Contractor shall not load nor permit any part of any structure to be loaded in any manner that shall endanger the structure, nor shall Contractor subject any part of the Work or adjacent property to stresses or pressures that shall endanger it.
- C. Contractor shall abide by all applicable rules and regulations of City with respect to conduct, including smoking, parking of vehicles, security regulations and entry into adjacent facilities owned by City.
- D. Contractor shall provide access to residents and businesses affected by the construction of this Project to the greatest extent possible, including providing temporary base and asphalt as needed.
- E. Contractor shall erect and maintain on Site a Project Bulletin Board, accessible to all Contractor and Subcontractor employees, upon which Contractor shall post and maintain, throughout the Project's duration, all employment and safety information required by law. Contractor further shall post complete Payment and Performance Bond information on the Project Bulletin Board, listing Contractor's bonding and insurance agencies/providers, to include agency contact names, address and telephone numbers.
- F. As applicable, City shall have appropriate Temporary Bench Marks (hereafter referred to as "TBM") and a baseline (for both horizontal and vertical projects, as applicable) established. As of the date of the Notice To Proceed, it is Contractor's responsibility to protect, preserve and reestablish (if required) the TBM and/or baseline. Construction staking and tolerances shall be in accordance with the "Manual of Practice for Land Surveying in the State of Texas Category 5".
- G. As applicable, Contractor shall layout its work from an established baseline and TBM indicated on the drawings and shall be responsible for all measurements in connection with the layout. Contractor shall furnish, at its own expense, all stakes, templates, platforms, equipment, tools, materials and labor required to layout any part of the work. Contractor shall provide cut sheets to City's inspector at minimum seven (7) calendar days prior to construction of street and drainage work. Contractor shall establish the necessary offsets, hubs and guards marked showing control designation and offsets for water, sewer or other utility Work, if present. Contractor shall provide cut sheets for improvements where Sewer profiles are provided for various phases of the project and cut sheets for Water profiles, if applicable. Contractor shall provide staking and preparation of cut sheets after receiving notice to proceed from City. If present, Contractor shall provide other utilities with cut sheets at minimum fifteen (15) calendar days prior to commence of water, sewer or other utility work. Contractor shall be responsible for maintaining and preserving a baseline and TBM indicated on the drawings for duration of construction. If such marks are destroyed, Contractor shall replace them at its own expense. At the end of construction of the Project, Contractor shall provide City a grade certificate prepared by a

Registered Professional Land Surveyor. This certificate shall state the infrastructure is constructed in accordance to the construction documents or as approved by City and the Engineer of Record, which is noted on the record plan set.

CIP 4.09

CUTTING AND PATCHING

- A. Contractor shall be responsible for all cutting, fitting or patching required to complete the Work or to make its parts fit together properly.
- B. Contractor shall not damage or endanger a portion of the Work or a fully or partially completed construction by either City or separate contractors by cutting, patching or otherwise altering such construction, or by excavation. Contractor shall not cut or otherwise alter such construction by City or a separate contractor except with written consent of City and, if City so designates, of such separate contractor and said consent shall not be unreasonably withheld. Contractor unreasonably shall not withhold from City or City's separate contractor Contractor's consent to cutting or otherwise altering the Work.
- C. Any part of the Work damaged by Contractor, either during installation or prior to Final Completion of the Work (or such earlier date established in accordance with the General Conditions), shall be repaired by Contractor to be equal in quality, appearance, serviceability and other respects to an undamaged item or part of the Work. Where this repair cannot fully be accomplished, a damaged item or part shall be replaced by Contractor.

CIP4.10

CLEANING UP

- A. During the progress of the Work, Contractor shall keep the Project Site and surrounding area including, but not limited to, creeks, drainage channels, easements and private property free from accumulations of waste materials, rubbish and other debris resulting from the Work. As applicable, Contractor shall clean, sweep, mop, brush and polish, as appropriate, the interior of the improvements and/or renovated areas including, but not limited to, any floors, carpeting, ducts, fixtures and ventilation units operated during construction, and shall clean exterior gutters, drainage, walkways, driveways and roofs of debris. If Contractor fails to clean up as provided in the Contract Documents, City may elect to do so and all costs incurred by City shall be paid by Contractor.
- B. Prior to Substantial Completion of the Work, Contractor shall remove all waste materials, rubbish and debris from and about the premises, as well as all tools, appliances, construction equipment and machinery and surplus materials, and shall leave the Project Site clean and ready for occupancy by City. As applicable, Contractor shall clean, sweep, mop, brush and polish, to City's satisfaction, the interior of the improvements and/or renovated areas including, but not limited to, any floors, carpeting, ducts, fixtures and ventilation units operated during construction, and shall clean exterior gutters, drainage, walkways, driveways and roofs of debris. Contractor shall restore to their original condition those portions of the Site not designated for alteration by the Contract Documents. If Contractor fails to clean up the premises as provided in the Contract Documents, City may elect to do so and all costs incurred by City shall be paid by Contractor.

CIP4.11

TEMPORARY STORM SEWER AND DRAIN CONNECTIONS.

- A. When existing storm sewers or drains have to be taken up or removed, Contractor shall, at its expense as part of the Work, provide and maintain temporary outlets and connections for all public and private storm sewers and drains. Contractor shall also provide for all storm sewage and drainage that shall be received from these storm drains and sewers. For this purpose, Contractor shall provide and maintain, at Contractor's own expense, adequate pumping facilities and temporary outlets or diversions. Contractor shall, at Contractor's own expense, construct such troughs, pipes or other structures that may be necessary and shall be prepared at all times to dispose of storm drainage and sewage received from these temporary connections until such time as the permanent connections are built and are in service. The existing storm sewers and connections shall be kept in service and maintained under the Contract, except where specified or ordered to be abandoned by Design Consultant. All storm water and sewage shall be disposed of in a satisfactory and lawful manner so that no nuisance is created and that the Work under construction shall be adequately protected.

CIP4.12 USE OF FIRE HYDRANTS.

- A. Contractor, Subcontractors and any other person working on the Project shall not open, turn off, interfere with, attach any pipe or hose to or connect anything with any fire hydrant, stop valve or stop cock, or tap any water main belonging to City, unless duly authorized in writing to do so by City.

CIP4.13 BARRICADES, LIGHTS AND WATCHMEN.

- A. If the Work is carried on, in or adjacent to any street, alley or public place, Contractor shall, at Contractor's own cost and expense, furnish, erect and maintain sufficient barricades, fences, lights and danger signals, provide sufficient watchmen and take such other precautionary measures as are necessary for the protection of persons or property and of the Work. All barricades shall be painted in a color that shall be visible at night and shall be illuminated by lights as required under the Contract Documents, or if none, under the City's Barricades Specifications. The term "lights," as used in this **Section 4.13**, shall mean flares, flashers or other illuminated devices. A sufficient number of barricades with adequate markings and directional devices also shall be erected to keep vehicles from being driven on or into any Work under construction. Contractor shall be held responsible for all damage to the Work due to failure of barricades, signs, lights and/or watchmen necessary to protect the Work. Whenever evidence is found of such damage, City or Design Consultant may order the damaged portion immediately removed and replaced by Contractor at Contractor's sole cost and expense. Contractor's responsibility for maintenance of barricades, signs, lights, and for providing watchmen, as required under this **Section 4.13**, shall not cease until the Project has been finally accepted by City.

CIP4.11 PAYMENT

- A. No separate payment will be made for work performed in accordance with this section of the specifications, and the cost thereof shall be included in the appropriate items of the Proposal and Bid Schedule.

END OF SECTION

TECHNICAL SPECIFICATIONS

SECTION CIP5 – CONTRACTOR USE OF PREMISES

CIP5.01 SCOPE OF WORK

- A. This specification covers the requirements for the Contractor's use of the premises for the Project.

CIP5.02 GENERAL

- A. Contractor shall limit his use of the premises, for work and for storage, to the areas designated on the Plans, or approved by the City.
- B. Contractor shall assume full responsibility for the protection and safekeeping of materials under this Contract stored on the site.
- C. Contractor shall move any stored materials, under Contractor's control, which interfere with operations of the City of Pflugerville.
- D. Contractor shall obtain and pay for the use of additional storage or work areas needed for operations.
- E. Water meters for construction shall not be issued to parties that are indebted to the City of Pflugerville.
- F. Any damage to existing facilities, including contamination, which may be caused by Contractor's personnel, callers, visitors, materials or equipment, shall be repaired or corrected at the sole expense of the Contractor.
- G. Any fence that is damaged or removed by the Contractor will be replaced at the Contractor's expense in like kind, and to the satisfaction of the Engineer and the City.

END OF SECTION

TECHNICAL SPECIFICATIONS

SECTION CIP6 – CONTROL OF WORK

CIP6.01 SCOPE OF WORK

- A. This specification covers the requirements for exercising control of work performed on the Project.

CIP6.02 AUTHORITY OF ENGINEER OR INSPECTOR

- A. The work will be done in accordance with the Contract, Plans and Specifications. The Engineer or Inspector will decide all questions which may arise as to the quality or acceptability of materials furnished and work performed and the interpretations of the Plans and Specifications. His decisions will be final, and he will have executive authority to enforce and make effective such decisions and orders.

CIP6.03 CONFORMITY WITH PLANS, SPECIFICATIONS AND SPECIAL PROVISIONS

- A. All work performed and all materials furnished shall be in reasonable close conformity with the lines, grades, cross sections, dimensions, details, gradations, physical and chemical characteristics of materials in accordance with tolerances shown on the Plans or indicated in the Specifications and Special Provisions. The limits establishing reasonable close conformity will be as defined in these items of the contract.
- B. In the event the City finds that the work performed or the materials used are not within reasonable close conformity with the Plans, Specifications and Special Provisions, the affected material or product shall be removed and replaced or otherwise satisfactorily corrected by and at the expense of the Contractor.
- C. Deviations from the Plans and approved working drawings as may be required will in all cases be determined by the City and authorized in writing. Before final acceptance of the project is issued by the City, the Contractor shall provide the City with a set of record drawings for the project certified by the Engineer of record.

CIP6.04 COORDINATION OF PLANS, SPECIFICATIONS AND SPECIAL PROVISIONS

- A. The Specifications, the accompanying Plans, Special Provisions, and Supplemental Agreements, are essential parts of the Contract, and a requirement occurring in one is as binding as though occurring in all. They are intended to be co-operative and to describe and provide for a complete work. In cases of disagreement, figured dimensions shall govern over scaled dimensions, the Plans shall govern over Specifications, and Special Provisions shall govern over both Specifications and Plans.

CIP6.05 AUTHORITY AND DUTIES OF INSPECTORS

- A. Inspectors will be authorized to inspect all work done and all materials furnished. Such inspection may extend to all or to any part of the work and to the preparation or Manufacturer of the materials to be used. Such inspection will not relieve the Contractor from any obligation to perform the work in accordance with the requirements of the Specifications. In case of any dispute arising between the Contractor and the Inspector as to materials furnished or the manner of performing the work, the Inspector will have authority to reject materials or suspend work until the question at issue can be referred to and decided by the City. The Inspector will not be authorized to revoke, alter, enlarge, or release any requirement of these Specifications, nor to approve or accept any portion of work, nor to issue instruction contrary to the Plans and Specifications. He will in no case act as foreman or perform other duties for the Contractor nor interfere with the management of the work.

CIP6.06

PLANT

- A. The Contractor shall furnish plant and equipment which will be efficient, appropriate and large enough to secure a satisfactory quality of work and a rate of progress which will insure the completion of the work within the time stipulated in the Proposal. If at any time such plant appears to the Engineer to be inefficient, inappropriate or insufficient for securing the quality of work required or for producing the rate of progress aforesaid, he may order the Contractor to increase the efficiency, change the character or increase the plant and equipment, and the Contractor shall conform to such order. Failure of the Engineer to give such order shall in no way relieve the Contractor of his obligations to secure the quality of work and rate of progress required.

CIP6.07

PRIVATE LAND

- A. The Contractor shall not enter or occupy private land outside of easements, except by written permission of the respective landowner. The Contractor shall provide the City of Pflugerville a copy of any agreement reached with private landowners.

CIP6.08

PIPE LOCATIONS

- A. Pipelines shall be located substantially as indicated on the Plans, but the Engineer and the City reserve the right to make such modifications in locations as may be found desirable to avoid interference with existing structures or for other reasons. Where fittings are noted on the Plans, such notation is for the Contractor's convenience and does not relieve him from laying and jointing different or additional items where required.

CIP6.09

OPEN EXCAVATIONS

- A. All open excavations shall be adequately safeguarded by providing temporary barricades, caution signs, lights and other means to prevent accidents to persons, and damage to property. The Contractor shall, at his own expense, provide suitable and safe bridges and other crossings for accommodating travel by pedestrians and workmen. Bridges provided for access during construction shall be removed when no longer required. The length or size of excavation will be controlled by the particular surrounding conditions, but shall always be confined to the limits prescribed by the Engineer. If the excavation becomes a hazard, or if it excessively restricts traffic at any point, the Engineer may require special construction procedures such as limiting the length of the open trench, prohibiting stacking excavated material in the street, and requiring that the trench shall not remain open overnight. The Contractor shall take precautions, such as fences and barricades, to prevent injury to the public due to open trenches. All trenches, excavated material, equipment, or other obstacles, which could be dangerous to the public, shall be well lighted at night. All trenches shall conform to the requirements of OSHA.

CIP6.10

TEST PITS

- A. Test pits for the purpose of locating underground pipelines or structures in advance of the construction shall be excavated and backfilled by the Contractor at the direction of the Engineer or the City. Test pits shall be backfilled immediately after their purpose has been satisfied and the surface restored and maintained in a manner satisfactory to the Engineer and the City.

CIP6.11

MAINTENANCE OF TRAFFIC

- A. Unless permission to close a street is received in writing from the proper authority, all excavated material shall be placed so that vehicular and pedestrian traffic may be maintained at all times. If the Contractor's operations cause traffic hazards, he shall repair the road surface, provide temporary ways, erect wheel guards or fences, or take other measures for safety satisfactory to the Engineer and the City.

- B. Detours around construction will be subject to the approval of the City and the Engineer. Where detours are permitted, the Contractor shall provide all necessary barricades and signs as required to divert the flow of traffic. While traffic is detoured, the Contractor shall expedite construction operations and periods when traffic is being detoured will be strictly controlled by the City.
- C. The Contractor shall take precautions to prevent injury to the public due to open trenches. Night watchmen may be required where special hazards exist, or police protection provided for traffic while work is in progress. The Contractor shall be fully responsible for damage or injuries whether or not police protection has been provided.

CIP6.12 BLASTING

- A. No blasting shall be allowed unless approved in writing by the City of Pflugerville.

CIP6.13 CARE AND PROTECTION OF PROPERTY

- A. The Contractor shall be responsible for the preservation of all public and private property, and shall use every precaution necessary to prevent damage thereto. If any direct or indirect damage is done to public or private property by or on account of any act, omission, neglect, or misconduct in the execution of the work on the part of the Contractor, such property shall be restored by the Contractor, at his expense, to a condition equal or better than existing before the damage was done, or he shall make good the damage in some other manner acceptable to the Engineer and the City.

CIP6.14 MAINTENANCE OF FLOW

- A. The Contractor shall, at his own cost, provide for the flow of sewers, drains and water courses interrupted during the progress of the work, and shall immediately cart away and remove all offensive matter. The entire procedure of maintaining existing flow shall be fully discussed with the Engineer and the City well in advance of the interruption of any flow.

CIP6.15 COOPERATION WITHIN THIS CONTRACT

- A. The Contractor shall cooperate with Subcontractors or trades, and shall assist in incorporating the work of other trades where necessary or required.
- B. Cutting and patching, drilling and fitting shall be carried out where required by the Contractor and his Subcontractor having jurisdiction, unless otherwise indicated herein or directed by the Engineer or the City.

CIP6.16 CLEANUP

- A. During the course of the work, the Contractor shall keep the site of his operations in as clean and neat a condition as is possible. The Contractor shall dispose of all rubbish resulting from the construction work and, at the conclusion of the work, he shall remove and haul away any surplus excavation, broken pavement, lumber, equipment, temporary structures, and any other refuse remaining from the construction operations, and shall leave the entire site of the work in a neat and orderly condition.

CIP6.17 FINAL INSPECTION

- A. Whenever the work provided for in, and contemplated under, the contract has been satisfactorily completed, the City will make the "Final Inspection". If the work is found to be satisfactory, the Contractor will be notified in writing of the acceptance of the same. The City will require a Certificate of Completion and Final Acceptance from the Inspector before any building, electric or plumbing permits will be issued or any City utilities provided. No such Certificate will be issued until all monuments have been set and record drawing reviewed by the Engineer of Record are provided to the City. If items are found in need of repair or completion, a final punch list will be generated and the items shall be completed by the Contractor. The City will inspect the punch list items one time following their completion. The cost for any subsequent inspections due to inadequate repair or completion of the punch list items shall be paid for by the Contractor or Developer at cost, but in no event will the cost be less than \$200.00 per inspection.

- B. Final acceptance of the Project or Development does not relieve the Contractor or Developer of the responsibility of insuring all work shown on the Plans has been completed. If any portion of the work is found at a later date to be inferior or incomplete, the Contractor or Developer shall replace or complete the work at no expense to the City in accordance with the City of Pflugerville General Conditions, if applicable.

CIP6.18

PAYMENT

- A. No separate payment will be made for work performed in accordance with this section of the specifications, and the cost thereof shall be included in the appropriate items of the Proposal and Bid Schedule.

END OF SECTION

TECHNICAL SPECIFICATIONS

SECTION CIP7 – CONTROL OF MATERIALS

CIP7.01 SCOPE OF WORK

- A. This specification covers the requirements for exercising control of materials used on the Project.

CIP7.02 SOURCES OF SUPPLY AND QUALITY OF MATERIALS

- A. The source of supply of each of the materials shall be approved by the City before any deliveries and at the option of the City, may be sampled and tested for determining compliance with the governing Specifications by the City before delivery begins. If it is found after trial that sources of supply previously approved do not produce uniform and satisfactory products, or if the product from any source proves unacceptable at any time, the Contractor shall furnish materials from other approved sources. Only materials conforming to the requirements of these Specifications and approved by the City shall be used in the work. All materials being used are subject to inspection or test at any time during their preparation or use. Any materials which have been tested and accepted at the source of supply may be subjected to a check test after delivery and all materials which, when retested, do not meet approval or have in any way become unfit for use shall not be used in the work.
- B. Throughout these Specifications where reference is made to ASTM, AASHTO or bulletins of the Texas Department of Transportation for the quality of materials or sampling and testing, the most current standard, tentative standard or bulletin issued prior to the date of the proposal shall govern.

CIP7.03 SAMPLES AND TEST

- A. All materials, before being incorporated in the work, shall be inspected, tested and approved by the City and any work in which materials are used without prior test and approval or written permission of the City may be ordered removed and replaced at the Contractor's expense. The Contractor shall be responsible for and pay for all charges of testing laboratories for services in conjunction with initial tests made on all imported materials to the project site including but not limited to embedment materials, fill materials, backfill materials, select material, crushed limestone base, sub-base, concrete, steel, wood forms, liquid asphalt, aggregate, water, cement, guard rail etc. Sampling and testing of all materials, on the project site will be coordinated by the Contractor and paid for by the City. The selection of the method of test shall be designated by the City. Where tests are required, other than those made in the laboratory, for the purpose of control in the manufacture of a construction item, the Contractor will be required to furnish such facilities and equipment as may be necessary to perform the tests and inspection and shall be responsible for calibration of all test equipment required. When requested, the Contractor shall furnish a complete written statement of the origin, composition, and/or manufacture of any or all materials that are to be used in the work. Testing of all materials and work shall conform to the Texas Department of Transportation "Manual of Testing Procedures" which outlines testing methods and procedures. Other Texas Department of Transportation Bulletins shall apply.

CIP7.04 PAYMENT

- A. No separate payment will be made for work performed under this section of the specifications, and the cost thereof shall be included in the appropriate items of the Proposal and Bid Schedule.

END OF SECTION

TECHNICAL SPECIFICATIONS

SECTION CIP8 – LEGAL RELATIONS AND RESPONSIBILITIES TO THE PUBLIC

CIP8.01 SCOPE OF WORK

- A. This specification covers the requirements for complying with all Federal, State, and local laws, ordinances, and regulations, which in any manner affect the conduct of the work on the Project.

CIP8.02 LAWS TO BE OBSERVED

- A. The Contractor shall make himself familiar with and at all times shall observe and comply with all Federal, State, and local laws, ordinances, and regulations which in any manner affect the conduct of the work and shall indemnify and save harmless the City and its representatives against any claim arising from the violation of any such law, ordinance, or regulation, whether by himself or by his employees.

CIP8.03 PERMITS, LICENSES AND TAXES

- A. The Contractor shall procure all permits and licenses, pay all charges, fee and taxes, and give all notices necessary and incident to the due and lawful prosecution of the work.

CIP8.04 RESTORATION OF SURFACES OPENED BY PERMIT

- A. The Contractor shall not allow any party to make an opening in the highway or street unless a duly authorized permit signed by the owner of the facility is presented. Until the acceptance of the work, the Contractor shall make all necessary repairs in the roadway where openings have been made by due authority.

CIP8.05 PUBLIC SAFETY AND CONVENIENCE

- A. The safety of the public and the convenience of traffic shall be regarded as of prime importance. Unless otherwise shown on the Plans or except as herein provided, all portions of the highway and street shall be kept open to traffic. It shall be the entire responsibility of the Contractor to provide for traffic along and across the highway and streets as well as for ingress and egress to private property all as specified herein, as shown on the Plans or as directed by the City.
- B. The Contractor shall plan and execute his operations in a manner that will cause the minimum interference with traffic. The Contractor shall secure the City's approval of his proposed plan of operation, sequence of work and methods of providing for the safe passage of traffic before it is placed into operation. If at any time during construction, the approved plan does not accomplish the intended purpose, due to weather or other conditions affecting the safe handling of traffic, the Contractor shall immediately make necessary changes in accordance with the latest version of the TMUTCD to correct the unsatisfactory conditions.
- C. If due to rains or other reasons, the shoulders, slopes and ditches become unsatisfactory for handling traffic, construction operations shall be suspended and the base course or surface area shall be opened to traffic. Where the Specifications require that traffic be carried over or along the proposed work, construction operations shall be so prosecuted and new material so kept that placement and spreading will allow the passage of traffic in comfort and safety.
- D. Where an Asphalt Surface Treatment is placed for the full width in an operation, traffic shall be carried on the shoulder slopes and ditches where appropriate. During the operation of placing asphalt and aggregate, the surface or pavement shall not be closed to traffic for a period of more than 45 minutes.

- E. During construction of proposed structures, unless otherwise shown on the Plans, the Contractor shall provide and maintain detours including temporary structures or crossovers of adequate structural design as may be required for the safety and convenience of the traffic.
- F. At night or otherwise, all equipment not in use shall be stored in such manner and such locations as not to interfere with the safe passage of traffic. The Contractor shall provide and maintain flagmen at such points and for such periods of time as may be required to provide for the safety and convenience of public travel and Contractor's personnel, and as directed by the City. Flagmen shall have a sense of responsibility for the safety of the public and the workers, adequate training in safe temporary traffic control practices, average intelligence, good physical condition, including sight, mobility, and hearing, mental alertness and the ability to react in an emergency, courteous but firm manner, and a neat appearance. When directing traffic, flagmen shall use the standard attire, flags and signals and follow the flagging procedure set forth in "Instructions to Flagmen" published by the Texas Department of Transportation.

CIP8.06

BARRICADES AND DANGER, WARNING AND DETOUR SIGNS

- A. The Contractor shall place and maintain in good condition, standard barricades and warning signs at each end of the project and at other locations therein as called for on the Plans or as called for in the Contractor's approved plan of operation. The signs shall be of standard design as shown on the Plans and in accordance with Texas Department of Transportation Standards.
- B. All barricades and signs remaining in place at night and all points of hazard to traffic shall be either retro-reflective with a material that has a smooth, sealed outer surface or illuminated by lights to show the same shape and similar color both day and night. Signs which refer to construction operations which do not apply after work has ended for the day, shall be moved to points out of the clear zone that are not visible to traffic until construction is resumed.
- C. The Contractor may provide special signs not covered by the Plans to protect the traveling public against special conditions or hazards, provided however, that such signs are first approved by the City.
- D. Upon completion of the work, all signs and evidences thereof shall be removed by the Contractor.

CIP8.07

PROJECT IDENTIFICATION SIGNAGE

- A. Project identification signage shall be in accordance with Section CIP14- PROJECT IDENTIFICATION SIGNAGE. This does not apply to private development Projects.

CIP8.08

USE OF EXPLOSIVES

- A. When the use of explosives is necessary for the prosecution of the work, the Contractor shall use the utmost care not to endanger life or property. All explosives shall be stored in a secure manner, and all storage places shall be marked clearly, "DANGEROUS - EXPLOSIVES". The method of storing and handling explosives and highly flammable materials shall conform with Federal and State laws and regulations. **The use of explosives must be approved in writing by the City prior to any use.**
- B. In advance of doing any blasting work, involving the use of electric blasting caps within 200 feet of any railroad track, the Contractor shall give at least 24 hours advance notice to the nearest Roadmaster, Section Foreman, Agent, Signal Maintainer or Telegraph Operator with the request that his Superintendent be advised immediately of the pending use of explosives.

CIP8.09

PROTECTION OF ADJOINING PROPERTY

- A. The Contractor shall take proper measures to protect the adjacent or adjoining property which might be damaged by any process of construction, and in case of any injury or damage resulting from any act or omission on the part of or on behalf of the Contractor, he shall restore at his own expense the damaged property to a condition equal or better than that existing before such injury or damage was done, or he shall make good such injury or damage in an acceptable manner.

CIP8.10

RESPONSIBILITY FOR DAMAGE CLAIMS

- A. The Contractor shall save harmless the City from all suits, actions or claims brought on account of any injuries or damages sustained by any person or property in consequence of any neglect in safeguarding the work by the Contractor, or from any claims or amounts arising or recovered under the “Workmen’s Compensation Laws” or any other laws. He shall be responsible for all damage or injury to property of any character occurring during the prosecution of the work resulting from any act, omission, neglect, or misconduct on his part in the manner or method of executing the work; or from his failure to properly execute the work; or from defective work or materials. He shall not be released from such responsibility until all claims have been settled and suitable evidence to that effect furnished the Council.
- B. The Contractor’s attention is directed to the fact that pipelines and other underground installations as may be shown on the Plans have been taken from the best available information. There may be other pipelines or installations. The Contractor shall save harmless the City from any and all suits or claims resulting from damage by his operations to any pipeline or underground installation.

CIP8.11

CONTRACTOR’S RESPONSIBILITY FOR WORK

- A. Until the final acceptance of the work by the City as evidenced in writing, it shall be under the charge and care of the Contractor. The Contractor shall rebuild and make good at his own expense all injuries and damages to the work occurring before its completion and acceptance. In case of suspension of work for any cause, the Contractor shall be responsible for the preservation of all materials. He shall provide suitable drainage of the roadway and shall erect temporary structures where required. The Contractor shall maintain the roadway in good and passable condition until final acceptance.
- B. Wherever, in the opinion of the City, any roadway or portion thereof is in suitable condition for travel, it shall be opened to traffic, as may be directed, and such opening shall not be held to be in any way the final acceptance of the roadway or any part of it or as a waiver of any of the provisions of the Contract. Where it is considered by the City to be in the public interest, any substantially completed roadway or portion thereof may be opened to traffic.

CIP8.12

PERSONAL LIABILITY OF PUBLIC OFFICIALS

- A. In carrying out the provisions of the contract or in exercising any power or authority granted thereunder, there shall be no liability upon the City or its authorized assistant, either personally or otherwise, as they are agents and representatives of the City.

CIP8.13

PROSECUTION OF WORK

- A. Prior to beginning construction operations, the Contractor shall submit to the City a chart or brief outlining the manner of prosecution of the work that he intends to follow in order to complete the Contract. Before any work is started on the project or development, a “Pre-Construction Conference”, shall be held between the City, Contractor, Developer and any other interested parties.

CIP8.14

PAYMENT

- A. No separate payment shall be made for work performed in accordance with this section of the specifications, and the cost thereof shall be included in the appropriate items of the Proposal and Bid Schedule.

END OF SECTION

TECHNICAL SPECIFICATIONS

SECTION CIP9 – ENVIRONMENTAL PROTECTION PROCEDURES

CIP9.01 SCOPE OF WORK

- A. This specification covers the requirements for the prevention of environmental pollution in conformance with applicable laws and regulations, during and as the result of construction operations under this Contract. For the purpose of this specification, environmental pollution is defined as the presence of chemical, physical, or biological elements or agents which adversely affect human health or welfare; unfavorably alter ecological balances of importance to human life; affect other species of importance to man; or degrade the utility of the environment for aesthetic and/or recreational purposes.
- B. The control of environmental pollution requires consideration of air, water and land, and involves management of noise and solid waste, as well as other pollutants.
- C. Schedule and conduct all work in a manner that will minimize the erosion of soils in the area of the work. Provide erosion control measures such as diversion channels, sedimentation or filtration systems, berms, seeding, mulching or other special surface treatments as are required to prevent silting and muddying of streams, rivers, impoundments, lakes, etc. All erosion control measures shall be in place in an area prior to any construction activity in that area. Specific requirements are specified in Section G6- SEDIMENTATION AND TEMPORARY EROSION CONTROL.
- D. These Specifications are intended to ensure that construction is achieved with a minimum of disturbance to the existing ecological balance between a water resource and its surroundings. These are general guidelines. It is the Contractor's responsibility to determine the specific construction techniques to meet these guidelines.
- E. All phases of sedimentation and erosion control shall comply with and be subject to the approval of the Texas Commission on Environmental Quality, and U.S. EPA.

CIP9.02 SUBMITTALS

- A. Within 30 days after the Notice to Proceed, the Contractor shall submit to the Engineer or the City for approval, technical product literature including descriptions of any special operations required, temporary roads and embankments, and all other pertinent data to illustrate conformance to the specification found within.

CIP9.03 APPLICABLE REGULATIONS

- A. Comply with all applicable Federal, State and local laws and regulations concerning environmental pollution control and abatement.

CIP9.04 NOTIFICATIONS

- A. The Engineer and/or City will notify the Contractor in writing of any non-compliance with the foregoing provisions or of any environmentally objectionable acts and corrective action to be taken. State or local agencies responsible for verification of certain aspects of the environmental protection requirements shall notify the Contractor in writing, through the Engineer, of any non-compliance with State or local requirements. The Contractor shall, after receipt of such notice from the Engineer or from the regulatory agency through the Engineer, immediately take corrective action. Such notice, when delivered to the Contractor or his/her authorized representative at the site of the work, shall be deemed sufficient for the purpose. If the Contractor fails or refuses to comply promptly, the City may issue an order stopping all or part of the work until satisfactory corrective action has been taken. No part of the time lost due to any such stop orders shall be made the subject of a claim for extension of time or for excess costs or damages by the Contractor unless it is later determined that the Contractor was in compliance.

CIP9.05

IMPLEMENTATION

- A. Prior to commencement of the work, the Contractor shall meet with the City to develop mutual understandings relative to compliance with this provision and administration of the environmental pollution control program. All environmental and pollution control features shall be in place prior to any construction.
- B. Remove temporary environmental control features, when approved by the Engineer, and incorporate permanent control features into the Project at the earliest practical time.

CIP9.06

PROTECTION OF WATERWAYS

- A. The Contractor shall observe the rules and regulations of the State of Texas and agencies of the U.S. Government prohibiting the pollution of any lake, stream, river, or wetland by the dumping of any refuse, rubbish, dredge material, or debris therein.
- B. Contractors are specifically cautioned that disposal of materials into any waters of the State must conform with the requirements of the Texas Commission on Environmental Quality, and an applicable permit from the U.S. Army Corps of Engineers.
- C. The Contractor shall be responsible for providing holding ponds or an approved method which will handle, carry through, or divert around his work all flows, including storm flows and flows created by construction activity, so as to prevent silting of waterways or flooding damage to the property or adjacent properties.
- D. The Contractor is responsible for researching the need for a U.S. EPA NPDES permit for the construction site. If one is required, the Contractor is responsible for obtaining the permit and for monitoring the site per the permit requirements until final completion.

CIP9.07

DISPOSAL OF EXCESS EXCAVATION AND OTHER WASTE MATERIALS

- A. Excess excavated material not required or suitable for backfill and other waste material must be disposed of at sites approved by the City and Engineer.
- B. Unacceptable disposal sites, include, but are not limited to, sites within a wetland or critical habitat and sites where disposal will have a detrimental effect on surface water or groundwater quality.
- C. The Contractor may make his own arrangements for disposal subject to submission of proof to the Engineer that the Owner(s) of the proposed site(s) has a valid fill permit issued by the appropriate governmental agency and submission of a haul route plan including a map of the proposed route(s).
- D. The Contractor shall provide watertight conveyance of any liquid, semi-liquid, or saturated solids which tend to bleed or leak during transport. No liquid loss from transported materials will be permitted whether being delivered to the construction site or being hauled away for disposal. Fluid materials hauled for disposal must be specifically acceptable at the selected disposal site.

CIP9.08

USE OF CHEMICALS

- A. All chemicals used during project construction or furnished for project operation, whether herbicide, pesticide, disinfectant, polymer, reactant or of other classification, must show approval of either the U.S. Environmental Protection Agency or the U.S. Department of Agriculture or any other applicable regulatory agency. Use of all such chemicals and disposal of residues shall be in conformance with the Manufacturer's instructions.
- B. Any oil or other hydrocarbon spilled or dumped during construction must be excavated and completely removed from the site prior to final acceptance. Soil contaminated by the Contractor's operations shall become the property of the Contractor, who will bear all costs of testing and disposal.
- C. Before a Contractor commences work, the following steps shall be completed.

1. The City will inform the Contractor of his rights under the Texas Hazards Communication Act.
2. The City will provide a copy of the Chemical List giving the hazardous chemicals to which the Contractor, his employees and agents may be exposed to on the Project site.
3. The City will provide copies of all Material Safety Data Sheets (MSDS) to the Contractor for the hazardous chemicals, which he may be exposed to on the Project site.
4. The City will inform the Contractor of his obligation to inform his employees and agents of each of the above requirements.
5. The Contractor shall provide MSDS for all hazardous chemicals he may bring onto the project site that the City's employees may be exposed to.
6. The Contractor shall sign a Contractor Acknowledgement certifying that he/she has received the information provided by the City on hazardous chemicals and maintain the Acknowledgement with the original Contract.

CIP9.09

EROSION CONTROL

- A. Provide positive means of erosion control such as shallow ditches around construction to carry off surface water. Erosion control measures, such as siltation basins, silt fences, rock berms, hay check dams, mulching, jute netting and other equivalent techniques, shall be used as appropriate. Flow of surface water into excavated areas shall be prevented. Ditches around the construction area shall also be used to carry away water resulting from dewatering of excavated areas. At the completion of the work, ditches shall be backfilled and the ground surface restored to original condition.

CIP9.10

PROTECTION OF STREAMS

- A. Care shall be taken to prevent, or reduce to a minimum, any damage to any stream from pollution by debris, sediment or other material, or from the manipulation of equipment and/or materials in or near such streams. Water that has been used for washing or processing, or that contains oils or sediments that will reduce the quality of the water in the stream, shall not be directly returned to the stream. Such waters will be diverted through a settling basin or filter before being directed into the streams.
- B. The Contractor shall not discharge water from dewatering operations directly into any live or intermittent stream, channel, wetlands, surface water or any storm sewer. Water from dewatering operations shall be treated by filtration, settling basins, or other approved method to reduce the amount of sediment contained in the water to allowable levels.
- C. All preventative measures shall be taken to avoid spillage of petroleum products and other pollutants. In the event of any spillage, prompt remedial action shall be taken in accordance with a Contingency Action Plan approved by the Texas Commission on Environmental Quality. Contractor shall submit two (2) copies of approved contingency plans to the Engineer.
- D. Water being flushed from structures or pipelines after disinfection, with a Cl₂ residue of 2 mg/l or greater, shall be treated with a dechlorination solution, in a method approved by the Engineer, prior to discharge.

PROTECTION OF LAND RESOURCES

- A. Land resources within the project boundaries and outside the limits of permanent work shall be restored to a condition, after completion of construction, that will appear to be natural and not detract from the appearance of the Project. Confine all construction activities to the appropriate areas shown on the Plans.
- B. Outside of areas requiring earthwork for the construction of the new facilities, the Contractor shall not deface, injure, or destroy trees or shrubs, nor remove or cut them without prior approval. No ropes, cables, or guys shall be fastened or attached to any existing nearby trees for anchorage unless specifically authorized by the Engineer. Where such special emergency use is permitted, first wrap the trunk with a sufficient thickness of burlap or rags over which softwood cleats shall be tied before any rope, cable, or wire is placed. The Contractor shall in any event be responsible for any damage resulting from such use.
- C. Where trees may possibly be defaced, bruised, injured, or otherwise damaged by the Contractor's equipment, dumping or other operations, protect such trees by placing boards, planks, or poles around them in accordance with Section S6- SEDIMENTATION AND TEMPORARY EROSION CONTROL. Monuments and markers shall be protected similarly before beginning operations near them.
- D. Any trees or other landscape feature scarred or damaged by the Contractor's equipment or operations shall be restored as nearly as possible to its original condition. The Engineer or the City will decide what method of restoration shall be used and whether damaged trees shall be treated and healed or removed and disposed of.

All scars made on trees by equipment, construction operations, or by the removal of limbs larger than one (1) inch in diameter shall be coated as soon as possible with an approved tree wound dressing. All trimming or pruning shall be performed in an approved manner by experienced workmen with saws or pruning shears. Tree trimming with axes will not be permitted.

Climbing ropes shall be used where necessary for safety. Trees that are to remain, either within or outside established clearing limits, that are subsequently damaged by the Contractor and are beyond saving in the opinion of the Engineer or the City, shall be immediately removed and replaced.

- E. The locations of the Contractor's storage, and other construction buildings, required temporarily in the performance of the work, shall be cleared portions of the job site or areas to be cleared as shown on the Plans and shall require written approval of the Engineer and shall not be within wetlands or floodplains. The preservation of the landscape shall be an imperative consideration in the selection of all sites and in the construction of buildings. Plans showing storage facilities shall be submitted for approval of the Engineer or the City.
- F. If the Contractor proposes to construct temporary roads or embankments and excavations for plant and/or work areas, he/she shall submit the following for approval at least 10 days prior to scheduled start of such temporary work.
 - 1. A layout of all temporary roads, excavations and embankments to be constructed within the work area.
 - 2. Details of temporary road construction.
 - 3. Plans and cross sections of proposed embankments and their foundations, including a description of proposed materials.
 - 4. A landscaping drawing showing the proposed restoration of the area. Removal of any trees and shrubs outside the limits of existing clearing area shall be indicated. The drawing shall also indicate location of required guard posts or barriers required to control vehicular traffic passing close to trees and shrubs to be maintained undamaged. The drawing shall provide for the obliteration of construction scars as such and shall provide for a natural appearing final condition of the area. Modification of the Contractor's approved drawings shall be made only

with the written approval of the Engineer. No unauthorized road construction, excavation or embankment construction including disposal areas will be permitted.

- G. Remove all signs of temporary construction facilities such as haul roads, work areas, structures, foundations of temporary structures, stockpiles of excess waste materials, or any other vestiges of construction as directed by the Engineer or the City. It is anticipated that excavation, filling and plowing of roadways will be required to restore the area to near natural conditions which will permit the growth of vegetation thereon. The disturbed areas shall be prepared and seeded as described in Section G7- LOAMING, HYDROSEEDING AND PERMANENT EROSION CONTROL, or as approved by the Engineer or the City.
- H. All debris and excess material will be disposed of outside wetland or floodplain areas in an environmentally sound manner.

CIP9.12 PROTECTION OF AIR QUALITY

- A. Burning. The use of burning at the project site for the disposal of refuse and debris will not be permitted.
- B. Dust Control. The Contractor will be required to maintain all excavations, embankment, subgrade, road bed, base course stockpiles, access roads, plant sites, waste areas, borrow areas, and all other work areas within or outside the project boundaries free from dust which could cause the standards for air pollution to be exceeded, and which would cause a hazard or nuisance to others.
- C. An approved method of stabilization consisting of sprinkling or other similar methods will be permitted to control dust. The use of petroleum products is prohibited. The use of chlorides may be permitted with approval from the Engineer or the City.
- D. Sprinkling, to be approved, must be repeated at such intervals as to keep all parts of the disturbed area at least damp at all times, and the Contractor must have sufficient competent equipment on the job to accomplish this if sprinkling is used. Dust control shall be performed as the work proceeds and whenever a dust nuisance or hazard occurs, as determined by the Engineer or the City.

CIP9.13 MAINTENANCE OF POLLUTION CONTROL FACILITIES DURING CONSTRUCTION

- A. During the life of this Contract, the Contractor shall maintain all facilities constructed for pollution control as long as the operations creating the particular pollutant are being carried out or until the material concerned has become stabilized to the extent that pollution is no longer being created.

CIP9.14 NOISE CONTROL

- A. The Contractor shall make every effort to minimize noises caused by his/her operations. Equipment shall be equipped with silencers or mufflers designed to operate with the least possible noise in compliance with State and Federal regulations.

CIP9.15 PAYMENT

- A. No separate payment will be made for work performed in accordance with this section of the specifications, and the cost thereof shall be included in the appropriate items of the Proposal and Bid Schedule.

END OF SECTION

TECHNICAL SPECIFICATIONS

SECTION CIP10 - SUBMITTALS

CIP10.01 SCOPE OF WORK

- A. This specification covers the requirements for submissions applicable to the following work-related submittals: Shop Drawings, Product Data, Samples, Mock Ups, Construction Photographs, and Construction or Submittal Schedules. Detailed submittal requirements will be specified in the technical specification sections.
- B. All submittals shall be clearly identified by reference to Specification Section, Paragraph, Drawing No. or Detail as applicable. Submittals shall be clear and legible and of sufficient size for sufficient presentation of data.

CIP10.02 SHOP DRAWINGS, PRODUCT DATA, SAMPLES

A. Shop Drawings

- 1. Shop drawings as specified in individual work Sections include, but are not necessarily limited to, custom-prepared data such as fabrication and erection/installation (working) drawings, scheduled information, setting diagrams, actual shopwork manufacturing instructions, custom templates, special wiring diagrams, coordination drawings, individual system or equipment inspection and test reports including performance curves and certifications, as applicable to the Work.
- 2. All shop drawings submitted by subcontractors for approval shall be sent directly to the Contractor for checking. The Contractor shall be responsible for their submission at the proper time so as to prevent delays in delivery of materials.
- 3. The Contractor shall check all subcontractor's shop drawings regarding measurements, size of members, materials, and details to satisfy himself that they conform to the intent of the Plans and Specifications. Shop drawings found to be inaccurate or otherwise in error shall be returned to the subcontractors for correction before submission thereof.
- 4. All details on shop drawings submitted for approval shall show clearly the relation of the various parts to the main members and lines of the structure, and where correct fabrication of the work depends upon field measurements, such measurements shall be made and noted on the Plans before being submitted for approval.

B. Product Data

- 1. Product data as specified in individual Sections, include, but are not necessarily limited to, standard prepared data for manufactured products (sometimes referred to as catalog data), such as the Manufacturer's product specification and installation instructions, availability of colors and patterns, Manufacturer's printed statements of compliance's and applicability, roughing-in diagrams and templates, catalog cuts, product photographs, standard wiring diagrams, printed performance curves and operational-range diagrams, production or quality control inspection and test reports and certifications, mill reports, product operating and maintenance instructions and recommended spare-parts listing and printed product warranties, as applicable to the work.

C. Samples

- 1. Samples specified in individual Sections, include, but are not necessarily limited to, physical examples of the work such as sections of manufactured or fabricated work, small cuts or containers of materials, complete units of repetitively-used products, color/texture/pattern swatches and range sets, specimens for coordination of visual effect, graphic symbols and units

of work to be used by the Engineer or the City for independent inspection and testing, as applicable to the work.

CIP10.03

CONTRACTOR'S RESPONSIBILITIES

- A. The Contractor shall review shop drawings, product data and samples, including those by subcontractors, prior to submission to determine and verify the following:
1. Field measurements
 2. Field construction criteria
 3. Catalog numbers and similar data
 4. Conformance with the Specifications
- B. Each shop drawing, sample and product data submitted by the Contractor shall have affixed to it the following Certification Statement including the Contractor's Company name and signed by the Contractor: "Certification Statement: by this submittal, I hereby represent that I have determined and verified all field measurements, field construction criteria, materials, dimensions, catalog numbers and similar data and I have checked and coordinated each item with other applicable approved shop drawings and all Contract requirements." Shop drawings and product data sheets eleven by seventeen (11" x 17") and smaller shall be bound together in an orderly fashion and bear the above Certification Statement on the cover sheet. The cover sheet shall fully describe the packaged data and include a listing of all items within the package. Provide to the Resident Project Representative a copy of each submittal transmittal sheet for shop drawings, product data and samples at the time of submittal of said drawings, product data and samples to the Engineer or the City.
- C. The Contractor shall utilize a 10 character submittal identification numbering system in the following manner:
1. The first character shall be a D, S, P, M, or R, which represents Shop/Working Drawing and other Product Data (D), Sample (S), Preliminary Submittal (P), Operating/Maintenance Manual (M), or Request for Information (R).
 2. The next sequence shall be the applicable Specification Section Number.
 3. The next three (3) digits shall be the numbers 001 - 999 to sequentially number each initial separate item or drawing submitted under each specific Section number.
 4. The last character shall be a letter, A-Z, indicating the submission, or resubmission of the same Drawing (i.e. A=1st submission, B=2nd submission, C=3d submission, etc.). A typical submittal number would be as follows:

D-C2-008-B
D = Shop Drawing
C2 = Specification Section for Concrete for Structures C2
008 = The eighth initial submittal under this specification section
B = The second submission (first resubmission) of that particular shop drawing
- D. Notify the Engineer or the City in writing, at the time of submittal, of any deviations in the submittals from the requirements of the Contract Documents.

- E. The review and approval of shop drawings, samples or product data by the Engineer or the City shall not relieve the Contractor from his/her responsibility with regard to the fulfillment of the terms of the Contract. All risks of error and omission are assumed by the Contractor and the Engineer or the City will have no responsibility therefore.
- F. No portion of the work requiring a shop drawing, sample, or product data shall be started nor shall any materials be fabricated or installed prior to the approval or qualified approval of such item. Fabrication performed, materials purchased or on-site construction accomplished which does not conform to approved shop drawings and data shall be at the Contractor's risk. The City will not be liable for any expense or delay due to corrections or remedies required to accomplish conformity.
- G. Project work, materials, fabrication, and installation shall conform with approved shop drawings, applicable samples, and product data.

CIP10.04

SUBMISSION REQUIREMENTS

- A. Make submittals promptly in accordance with approved schedule, and in such sequence as to cause no delay in the Work or in the work of any other Contractor.
- B. Each submittal, appropriately coded, will be returned within 30 working days following receipt of submittal by the Engineer or the City.
- C. Number of submittals required:
 - 1. Shop Drawings as defined in Paragraph G10.02 A: Six (6) copies.
 - 2. Product Data as defined in Paragraph G10.02 B: Six (6) copies.
 - 3. Samples: Submit the number stated in the respective Specification Sections.
- D. Submittals shall contain:
 - 1. The date of submission and the dates of any previous submissions.
 - 2. The Project title and number.
 - 3. Contractor identification.
 - 4. The names of:
 - a. Contractor
 - b. Supplier
 - c. Manufacturer
 - 5. Identification of the product, with the specification section number, page and paragraph(s).
 - 6. Field dimensions, clearly identified as such.
 - 7. Relation to adjacent or critical features of the Work or materials.
 - 8. Applicable standards, such as ASTM or Federal Specification numbers.
 - 9. Identification of deviations from Contract Documents.
 - 10. Identification of revisions on re-submittals.
 - 11. Two (2) five-inch by three-inch (5"x3") blank space for Contractor and Engineer stamps.

REVIEW OF SHOP DRAWINGS, PRODUCT DATA, WORKING DRAWINGS AND SAMPLES

- A. The review of shop drawings, data, and samples will be for general conformance with the design concept and Contract Documents. They shall not be construed as:
1. Permitting any departure from the Contract requirements;
 2. Relieving the Contractor of responsibility for any errors, including details, dimensions, and materials; and/or
 3. Approving departures from details furnished by the Engineer or the City, except as otherwise provided herein.
- B. The Contractor remains responsible for details and accuracy, for coordinating the work with all other associated work and trades, for selecting fabrication processes, for techniques of assembly, and for performing work in a safe manner.
- C. If the shop drawings, data or samples as submitted describe variations and show a departure from the Contract requirements which the Engineer finds to be in the interest of the City and to be so minor as not to involve a change in Contract Price or time for performance, the Engineer may return the reviewed drawings without noting an exception.
- D. Submittals will be returned to the Contractor under one of the following codes.

Code 1 "REVIEWED" is assigned when there are no notations or comments on the submittal. When returned under this code the Contractor may release the equipment and/or material for manufacture.

Code 2 "PROVIDE AS NOTED". This code is assigned when a confirmation of the notations and comments IS NOT required by the Contractor. The Contractor may release the equipment or material for manufacture; however, all notations and comments must be incorporated into the final product.

Code 3 "PROVIDE AS NOTED/CONFIRM". This combination of codes is assigned when a confirmation of the notations and comments IS required by the Contractor. The Contractor may release the equipment or material for manufacture; however, all notations and comments must be incorporated into the final product. This confirmation shall specifically address each omission and nonconforming item that was noted. Confirmation is to be received by the Engineer within 15 calendar days of the date of the Engineer's transmittal requiring the confirmation.

Code 4 "PROVIDE AS NOTED/RESUBMIT". This combination of codes is assigned when notations and comments are extensive enough to require a re-submittal of the package. The Contractor may release the equipment or material for manufacture; however, all notations and comments must be incorporated into the final product. This re-submittal is to address all comments, omissions and non-conforming items that were noted. Re-submittal is to be received by the Engineer within 15 calendar days of the date of the Engineer's transmittal requiring the re-submittal.

Code 5 "NOT APPROVED" is assigned when the submittal does not meet the intent of the Contract Documents. The Contractor must resubmit the entire package revised to bring the submittal into conformance. It may be necessary to resubmit using a different manufacturer/vendor to meet the Contract Documents.

Code 6 "COMMENTS ATTACHED" is assigned where there are comments attached to the returned submittal which provide additional data to aid the Contractor.

Codes 1 through 5 designate the status of the reviewed submittal with Code 6 showing there has been an attachment of additional data.

- E. Re-submittals will be handled in the same manner as first submittals. On re-submittals the Contractor shall direct specific attention, in writing on the letter of transmittal and on resubmitted shop drawings by use of revision triangles or other similar methods, to revisions other than the corrections requested by the Engineer, on previous submissions. Any such revisions which are not clearly identified shall be made at the risk of the Contractor. The Contractor shall make corrections to any work done because of this type revision that is not in accordance to the Contract Documents as may be required by the Engineer.
- F. Partial submittals may not be reviewed. The Engineer will be the only judge as to the completeness of a submittal. Submittals not complete will be returned to the Contractor, and will be considered "Not Approved" until resubmitted. The Engineer may at his/her option provide a list or mark the submittal directing the Contractor to the areas that are incomplete.
- G. If the Contractor considers any correction indicated on the shop drawings to constitute a change to the Contract Documents, the Contractor shall give written notice thereof to the Engineer at least seven (7) working days prior to release for manufacture.
- H. When the shop drawings have been completed to the satisfaction of the Engineer, the Contractor shall carry out the construction in accordance therewith and shall make no further changes therein except upon written instructions from the Engineer.

CIP10.06 DISTRIBUTION

- A. Distribute reproductions of approved shop drawings and copies of approved product data and samples, where required, to the job site file and elsewhere as directed by the Engineer. Number of copies shall be as directed by the Engineer but shall not exceed six (6).

CIP10.07 MOCK UPS

- A. Mock Up units as specified in individual Sections include, but are not necessarily limited to, complete units of the standard of acceptance for that type of work to be used on the Project. Remove at the completion of the Work or when directed.

CIP10.08 GENERAL PROCEDURES FOR SUBMITTALS

- A. Coordination of Submittal Times: Prepare and transmit each submittal sufficiently in advance of performing the related work or other applicable activities, or within the time specified in the individual work sections, of the Specifications, so that the installation will not be delayed by processing times including disapproval and re-submittal (if required), coordination with other submittals, testing, purchasing, fabrication, delivery and similar sequenced activities. No extension of time will be authorized because of the Contractor's failure to transmit submittals sufficiently in advance of the Work.

END OF SECTION

TECHNICAL SPECIFICATIONS

SECTION CIP11 – TRENCH SAFETY REQUIREMENTS

CIP11.01 SCOPE OF WORK

- A. This specification covers the requirements to plan, design, construct, install, maintain, monitor, modify as necessary, and remove upon completion, a Trench Safety System as specified herein.
- B. The requirements of this Section apply to all trenches which equal or exceed a depth of five (5) feet, measured from the ground surface at the highest side of the trench to the trench bottom.
- C. All applicable and non-conflicting portions of Section G4- TRENCHING, BACKFILLING AND COMPACTION apply as appropriate.

CIP11.02 SUBMITTALS

- A. Within 30 days after the Notice to Proceed, but not less than 10 calendar days prior to execution of any trench excavation operations, the Contractor shall submit a site specific Trench Safety System Conformance Affidavit stating that operations will be conducted in full conformance with the OSHA Standards.
 - 1. The Conformance Letter shall also describe the Trench Safety System techniques proposed to be used on the Project.
 - 2. Specific references to the applicable OSHA Standards sections shall be included for each technique to be used.
- B. The Trench Safety System Plan shall be in writing, site specific and sufficiently detailed and clear to be understandable and usable by all personnel who will be executing, supervising and witnessing the trenching operations. A copy of the Trench Safety System Plan shall be available at the site of trenching operations at all times.
- C. If borings and/or detailed geotechnical analyses are required to develop the Trench Safety System Plan, they shall be executed by the Contractor at his cost.
- D. For trenches having depths greater than the various limits given in the OSHA Standards (8, 12 or 20 feet, depending on the techniques used), a site specific protective system shall be designed by a Registered Professional Engineer, registered in the State of Texas experienced in soil mechanics and structural design. The design shall be signed, sealed and dated by the Professional Engineer, and it shall identify those specific locations where the design is applicable.

CIP11.03 GENERAL

- A. All materials and products incorporated into the Trench Safety System shall be suitable for their intended uses; shall meet all design criteria and parameters used by the Trench Safety System designer; and shall meet all applicable requirements of OSHA Standards.

CIP11.04 METHODS OF PROVIDING FOR TRENCH SAFETY

- A. Protective systems referenced in this Section shall be as defined and described in 29 CFR 1962.652, "Requirements for Protective Systems."

- B. It is the duty, responsibility and prerogative of the Contractor to determine the specific applicability of a proposed Trench Safety System for each field condition encountered on the Project. Contractor specifically holds the City, Engineer, and any of their designated representatives harmless in any actions resulting from the failure or inadequacy of the Trench Safety System used to complete the Project.
- C. Unless otherwise noted on the drawings or excluded below, Sloping/Benching, Trench Shielding with trench boxes, and/or Sheeting/Shoring/Bracing protective systems may be used on this Project.
- D. Restrictions on the use of the various protective systems for this Project are as follows:
 - 1. Sloping or Benchng. Allowed with prior approval from the City.
 - 2. Trench Shields/Boxes. No restrictions.
 - 3. Sheeting/Shoring/Bracing. No restrictions.

CIP11.05 INSPECTION DUTIES OF CONTRACTOR

- A. Provide a Competent Person, as defined in the OSHA Standards, to make frequent inspections of the trenching operations and the Trench Safety System in full conformance with the OSHA Standards.
- B. If evidence of a possible cave-in or landslide is apparent, all work in the trench shall immediately cease and not be resumed until all necessary precautions have been taken to safeguard personnel entering the trench.
- C. In an emergency situation, which may threaten or affect the safety or welfare of any persons or properties, the Contractor shall act at his discretion to prevent possible damage, injury or loss. Any additional compensation or time extension claimed for such actions shall be considered in view of the cause of the emergency and in accordance with the General Conditions.

CIP11.06 MEASUREMENT AND PAYMENT

- A. Payment for the Trench Safety Plan shall be on a Lump Sum price basis, the Lump Sum price being as given in the Bid Proposal.
- B. Payment for the Trench Safety Plan Implementation shall be on a unit price basis, the unit price being as given in the Bid Proposal, and the unit of measure being linear feet of trench and/or square foot of bore pit or structure, without regard to whether specific trench safety precautions are required or used for the trench reach being measured.

END OF SECTION

TECHNICAL SPECIFICATIONS

SECTION CIP12 – TESTING OF PIPELINES AND MANHOLES

CIP12.01 SCOPE OF WORK

- A. This specification covers the requirements to perform ex-filtration testing and deflection testing of gravity pipelines and to perform pressure and leakage testing of pressure pipelines.

CIP12.02 SUBMITTALS

- A. Within 30 days after the Notice to Proceed, the Contractor shall submit to the Engineer or the City for approval, technical product literature including a description of the deflection test procedure for flexible pipe greater than 27-inches in diameter, video inspection of gravity wastewater lines, and all other pertinent data to illustrate conformance to the specification found within.

CIP12.03 GENERAL

- A. The entire length of the installed gravity line and the force main shall be field tested for water tightness. Gravity wastewater lines shall be video taped by camera.
- B. Hydrostatic pressure and leakage tests shall be made on all pressure pipelines carrying wastewater or water.
- C. All labor and equipment, including, but not limited to test pump with regulated by-pass meters and gauges required for conducting pipeline tests, shall be furnished by the Contractor. The Contractor shall furnish equipment and necessary piping as required to transport water used in testing from source to test location.
- D. Time and sequence of testing shall be scheduled by the Contractor, subject to observation and approval by the City. The Contractor shall provide adequate labor, tools and equipment to operate valves and to locate and repair any leaks discovered during the initial filling of the pipeline prior to actual testing or during the course of the tests.

CIP12.04 CLEANING

- A. At the conclusion of the work, thoroughly clean all pipelines by flushing with water or other means to remove all dirt, stones, pieces of wood, or other material which may have entered the pipes during the construction period. Debris cleaned from the lines shall be removed from the low end of the pipeline. If after this cleaning, obstructions remain, they shall be removed. After the pipelines are cleaned and if the groundwater level is above the pipe or following a heavy rain, the Engineer will examine the pipes for leaks. If any defective pipes or joints are discovered, they shall be repaired, and/or replaced by the Contractor at his expense.

CIP12.05 TEST PROCEDURES FOR GRAVITY PIPELINES AND MANHOLES

- A. Scope: After sewers and manholes have been installed and backfilled, subject newly laid gravity lines and manholes to a leakage test. Contractor to furnish all labor, materials, tools and equipment to test lines. Take such precautions as required to prevent damage to lines and appurtenances being tested. Repair any damage resulting from test at Contractor's expense. Conduct test in presence of Engineer or designated City Representative.
- B. Test Procedures for Leakage Test of Gravity Sewer: Contractor, at his option, may test lines by hydrostatic or low pressure air test as specified below. However, the Engineer may direct a specific test be performed in specified areas of the Project.

C. Infiltration or Exfiltration Test (for Gravity Sewer)

1. Preparation: Seal ends of line section being tested with water tight plugs, equipped with pipe riser inserted and braced in the inlet of the manholes. Fill section with water 24-hours prior to start of test. Fill slowly from downstream manhole in test section so that no air is trapped in the line. Leave outlets of stacks and service lines exposed and unplugged until after exfiltration test has been made. Outlets terminating below level of test water surface to be temporarily extended upward by installing additional lengths of pipe. After completion of satisfactory test, remove lengths of pipe added for test.
2. Duration of Test: Test for 24-hours. Minimum head of either two (2) feet measured above the crown, inside pipe at upper end of section or four (4) feet measured above trench water table, whichever is higher, so that a net positive of two (2) feet TCEQ is used for testing.
3. Allowable Leakage: Allowable leakage or exfiltration in any individual section under construction shall not exceed 10 gallons per inch of inside diameter per mile of pipe per 24 hours.

D. Low Pressure Air Test

1. Preparation: Clean pipe to be tested by propelling snug fitting inflated rubber ball through the pipe with water or by use of water jet cleaning equipment. After manhole to manhole reach of pipe has been backfilled and cleaned, pneumatic plugs shall be placed in the line at each manhole and inflated to 25 psig. Add air slowly to the section under test until the internal pressure of 4.0 psig is obtained. Allow at least two (2) minutes for air temperature to stabilize, adding only the amount of air required to maintain pressure.

2. Duration of Test and Allowable Leakage

Decrease pressure to 3.5 psig and start stopwatch. Determine the time in seconds that is required for the internal air pressure to reach 2.5 psig. Minimum permissible pressure holding times are indicated in seconds and shall be computed by the following equation:

$$T = (0.085 \times D \times K) / Q$$

T = time for pressure to drop 1.0 pound per square inch gauge in seconds

K = 0.000419 x D x L, but not less than 1.0

D = average inside diameter in inches

L = length of line of same pipe size being tested, in feet

Q = rate of loss assume 0.0015 cubic feet per minute per square foot internal surface shall be used

Since K value of less than 1.0 shall not be used, there are minimum times for each pipe diameter as outlined below:

Pipe Diameter (inches)	Minimum Time (seconds)	Length for Minimum Time (feet)	Time for Longer Length (seconds)
6	340	398	0.855(L)
8	454	298	1.520(L)
10	567	239	2.374(L)
12	680	199	3.419(L)
15	850	159	5.342(L)
18	1020	133	7.693(L)
21	1190	114	10.471(L)
24	1360	100	13.676(L)

Pipe Diameter	Minimum Time	Length for Minimum Time	Time for Longer Length
27	1530	88	17.309(L)
30	1700	80	21.369(L)
33	1870	72	25.856(L)
36	2040	66	30.771(L)

The test may be stopped if no pressure loss has occurred during the first 25% of the calculated testing time. If any pressure loss or leakage has occurred during the first 25% of the testing period, then the test shall continue for the entire test duration as outlined above or until failure. Lines with a 27-inch average inside diameter and larger may be air tested at each joint. If the joint test is used, a visual inspection of the joint shall be performed immediately after testing. The pipe is to be pressurized to 3.5 psi greater than the pressure exerted by groundwater above the pipe. Once the pressure has stabilized, the minimum time allowable for the pressure to drop from 3.5 psi gauge to 2.5 psi gauge shall be 10 seconds.

E. Test Procedures for Hydrostatic Test for Manholes

1. Manholes shall be tested for leakage separately and independently of the wastewater lines by hydrostatic exfiltration testing, or other methods acceptable to the City. If a manhole fails a leakage test, the manhole must be made water tight and retested. The maximum leakage for hydrostatic testing shall be 0.025 gallon per vertical foot per hour. Alternative test methods must ensure compliance with the above allowable leakage. Hydrostatic exfiltration testing shall be performed as follows: all wastewater lines coming into the manhole shall be sealed with an internal pipe plug, then the manhole shall be filled with water and maintained full for at least one (1) hour. For concrete manholes a wetting period of 24-hours may be used prior to testing in order to allow saturation of the concrete.

F. Test Procedures for Vacuum Testing Manholes

1. In lieu of the hydrostatic exfiltration test, manholes may be tested by vacuum. Manholes tested by vacuum shall be performed by the Contractor in compliance with these specifications.
2. Manholes shall be tested after installation of all connections (existing and/or proposed) in place. All lift holes shall be plugged with an approved non-shrink grout and all drop connections and gas sealing connections shall be installed prior to testing. The lines entering the manhole shall be temporarily plugged with the plugs braced to prevent them from being drawn into the manhole. The plugs shall be installed in the lines beyond the drop-connections, gas sealing connections, etc. The test head shall be placed inside the frame at the top of the manhole and inflated in accordance with the manufacturer's recommendations. A vacuum of 10-inches of mercury shall be drawn, and the vacuum pump shall be turned off. With the valve closed, the level of vacuum shall be read after the required test time as shown in the following table. If the drop in the level is less than one (1) inch of mercury (final vacuum of nine (9) inches of mercury), the manhole will have passed the vacuum test. The required test time shall be three (3) minutes.
3. Manholes which have a final vacuum of nine (9) inches of mercury after the time indicated will be accepted. If there has been no pressure loss during the first 23-seconds the test may be stopped and the manhole will be accepted. Any manhole which fails the vacuum test as described above shall be repaired with an approved non-shrink grout or other material acceptable to the Engineer and the City based on the material from which the manhole is constructed. The manhole shall be retested as described above until a successful test is made.

G. Exfiltration Test

1. Preparation: Seal ends of manhole being tested with watertight plugs. Fill manhole 24-hours prior to start of test. Manholes to be filled to top of manhole cone section.
2. Duration of Test: The test shall be performed for a 24-hour duration.
3. Allowable Leakage: No leakage is allowed. The water elevation shall be the same at beginning and end of test period.

H. Deflection Testing

1. Deflection tests shall be performed on all flexible pipes. For pipes with inside diameters less than 27-inches, a rigid mandrel shall be used to measure deflection. For pipelines with an inside diameter of 27-inches and greater, the Contractor shall submit to the Engineer the proposed method, with which shall provide a precision of \pm two tenths of one percent (0.2%) deflection, for review and approval by the Texas Natural Resource Conservation Commission. The test shall be conducted after final backfill has been in place at least 30 days in the presence of a representative of the City's Utilities Department. No pipe shall exceed a deflection of five percent (5%). If a pipe should fail to pass the deflection test, the problem shall be corrected and a second test shall be conducted after the final backfill has been in place an additional 30 days. Test shall be performed without mechanical pulling devices.
 2. Mandrel Sizing: The rigid mandrel shall have an outside diameter (O.D.) equal to 95% of the inside diameter (I.D.) of the pipe. The inside diameter of the pipe, for the purpose of determining the outside diameter of the mandrel, shall be the average outside diameter of the pipe minus two minimum wall thickness for O.D. controlled pipe and the average inside diameter for the I.D. Controlled pipe, all dimensions shall be per appropriate standard. Statistical or other "tolerance packages" shall not be considered in mandrel sizing.
 3. Mandrel Design: The rigid mandrel shall be constructed of a metal or rigid plastic material that can withstand 200 psi without being deformed. The mandrel shall have nine or more "runners" or "legs" as long as the total number of legs is an odd number. The barrel section of the mandrel shall have a length of at least 75% of the inside diameter of the pipe. A proving ring shall be provided and used for each size mandrel in use.
 4. Method Options: Adjustable or flexible mandrels are prohibited. A television inspection is not a substitute for the deflection test. A deflectometer may be approved provided the Contractor notifies the Engineer in a timely manner and submits adequate information for the Engineer to submit to the Texas Natural Resource Conservation Commission for review and approval. Mandrels with removable legs or runners may also be approved provided the Contractor notifies the Engineer in a timely manner and submits adequate information for the Engineer to submit to the Texas Natural Resource Conservation Commission for review and approval.
- I. Repairs of Lines: Remove and replace or make approved corrective repairs to any section of line or manhole which has leakage that exceeds above amounts. Repair any individual leaks that may appear whether or not overall section meets leakage requirements. Individual leaks will ordinarily be revealed by looking through sewer with a light while groundwater level is over sewer, during water tamping operations or immediately after water leakage is emptied from sewer.
- J. Retest: Sewers and/or manholes failing to meet requirements of leakage test will, after repair by Contractor, be tested again for leakage. No sewer or manhole will be accepted until leakage is less than allowable amount.

K. Video Inspection

1. The use of a television camera for inspection prior to placing the sewer in service will be required. Video inspection is at the cost of the Contractor, and copies of the videotapes will be presented to the City prior to final acceptance. Two (2) copies of the videotapes shall be submitted to the City along with a letter of concurrence from the Project Engineer acknowledging that all newly constructed sewer within the project has been videotaped and that he/she has reviewed the videotape and has not found any deficiencies in the videotaped sewer.
2. Post construction video of the gravity wastewater lines will be evaluated on a case-by-case basis for acceptance. Preparation for video taping of wastewater line shall be as follows:
 - a. Flush and clean the gravity wastewater line prior to video taping.
 - b. The videotape shall display the station, in accordance with the Plans and Standards, and counter on the screen. Manhole numbers and stations shall correspond to the contract documents.
 - c. If debris is evident in the line during the video, the line will be flushed and cleaned to allow a clean video.
 - d. All manholes will be identified at the beginning and end of the video corresponding to contract documents with upstream and downstream ends identified.

L. Golf Ball Test

1. During the video inspection, water shall be flowed into the pipe to permit meaningful observations. Any pipe settlement which causes excessive ponding of water in the pipe shall be cause for rejection. Excessive ponding shall be defined as a golf ball (1-5/8" dia.) submerged at any point along the line.

CIP12.06

TEST PROCEDURES FOR PRESSURE PIPELINES

A. General

1. After the pipe has been laid and backfilled and the backfill has been otherwise consolidated, all newly laid pipe, or any valved section thereof, shall be subjected to the hydrostatic pressure specified below for that particular type of pipe. The duration of the hydrostatic test shall be at least two (2) hours. Unless otherwise specified or noted on the Plans. All meters, fixtures, devices or appliances which are connected to the pipeline system and which might be damaged if subjected to the specified test pressure shall be disconnected and the ends of the branch lines plugged or capped during the testing procedures.
2. Each valved (capped or plugged) section of pipe shall be filled slowly with water and all air shall be expelled. If permanent air vents are not located at all high points, the Contractor shall install, at his own expense, corporation or blow-off cocks at such points so that air can be expelled as filling takes place. After verification that all air has been expelled, the cocks shall be closed and the pipe kept filled until tested. All exposed pipe, fittings, valves, hydrants and joints shall be examined while under test pressure and all visible leaks shall be stopped. Any cracked or defective pipe, fittings, valves or hydrants discovered during testing shall be removed and replaced by the Contractor. Replacement shall be with sound material and the test shall be repeated until satisfactory to the City.

- B. Special Requirements: Where any section of pipeline is provided with concrete reaction blocking, the hydrostatic pressure shall not be made until at least five (5) days have elapsed after installation of the blocking. However, if high-early-strength cement is used in the concrete, two (2) days shall have elapsed prior to testing.
- C. Leakage Test: A Leakage Test will be conducted on each valved section over the entire Project. The leakage test shall be at 150 psi for at least four (4) hours.
- D. Allowable Leakage
1. The allowable hydrostatic leakage rate shall be based on the following formula:

$$L = \frac{SD\sqrt{P}}{133,200}$$

L = testing allowance in gallons per hour

S = length of pipe tested in feet

D = nominal diameter of the pipe in inches

P = average test pressure during the hydrostatic test in pounds per square inch (gauge)

Table 6A
Hydrostatic testing allowance per 1,000 ft of pipeline* - *gph*†

Avg. Test Pressure <i>psi</i>	Nominal Pipe Diameter – in.																	
	3	4	6	8	10	12	14	16	18	20	24	30	36	42	48	54	60	64
450	.48	.64	.95	1.27	1.59	1.91	2.23	2.55	2.87	3.18	3.82	4.78	5.73	6.69	7.64	8.60	9.56	10.19
400	.45	.60	.90	1.20	1.50	1.80	2.10	2.40	2.70	3.00	3.60	4.50	5.41	6.31	7.21	8.11	9.01	9.61
350	.42	.56	.84	1.12	1.40	1.69	1.97	2.25	2.53	2.81	3.37	4.21	5.06	5.90	6.74	7.58	8.43	8.99
300	.39	.52	.78	1.04	1.30	1.56	1.82	2.08	2.34	2.60	3.12	3.90	4.68	5.46	6.24	7.02	7.80	8.32
275	.37	.50	.75	1.00	1.24	1.49	1.74	1.99	2.24	2.49	2.99	3.73	4.48	5.23	5.98	6.72	7.47	7.97
250	.36	.47	.71	.95	1.19	1.42	1.66	1.90	2.14	2.37	2.85	3.56	4.27	4.99	5.70	6.41	7.12	7.60
225	.34	.45	.68	.90	1.13	1.35	1.58	1.80	2.03	2.25	2.70	3.38	4.05	4.73	5.41	6.03	6.76	7.21
200	.32	.43	.64	.85	1.06	1.28	1.48	1.70	1.91	2.12	2.55	3.19	3.82	4.46	5.09	5.73	6.37	6.80
175	.30	.40	.59	.80	.99	1.19	1.39	1.59	1.79	1.98	2.38	2.98	3.58	4.17	4.77	5.36	5.96	6.36
150	.28	.37	.55	.74	.92	1.10	1.29	1.47	1.66	1.84	2.21	2.76	3.31	3.86	4.41	4.97	5.52	5.88
125	.25	.34	.50	.67	.84	1.01	1.18	1.34	1.51	1.68	2.01	2.52	3.02	3.53	4.03	4.53	5.04	5.37
100	.23	.30	.45	.60	.75	.90	1.05	1.20	1.35	1.50	1.80	2.25	2.70	3.15	3.60	4.05	4.50	4.80

* If the pipeline under test contains sections of various diameters, the testing allowance will be the sum of the testing allowance for each size.

† Calculated on the basis of Eq. 1.

- a. These formulas are based on a testing allowance of 11.65 gpd/mi/in. (1.079 L/d/km/mm) of nominal diameter at a pressure of 150 psi (1,034 kPa).
- b. 5.2.1.6.1 Testing allowance at various pressures is shown in Tables 6A and 6B.
- c. 5.2.1.6.2 When testing against closed metal-seated valves, an additional testing allowance per closed valve of 0.0078 gal/h/in. (1.2 mL/h/mm) of nominal valve size shall be allowed.
- d. 5.2.1.6.3 When hydrants are in the test section, the test shall be made against the main valve in the hydrant.

- e. 5.2.1.7 Acceptance of installation. Acceptance shall be determined on the basis of testing allowance. If any test of laid pipe discloses a testing allowance greater than that specified in Sec. 5.2.1.6, repairs or replacements shall be accomplished in accordance with the specifications.
 - f. 5.2.1.7.1 All visible leaks are to be repaired regardless of the allowance used for testing.
2. If such testing discloses leakage in excess of this specified allowable, the Contractor, at his expense, shall locate and correct all defects in the pipeline until the leakage is within the specified allowance. All known leaks, irregardless of this test, shall be repaired.
- E. Pressure Test: After satisfactorily completing the leakage test, each valved section over the entire project, shall be tested at 200 psi for a sufficient period (approximately 10 min) to discover all leaking or defective materials and/or workmanship.
- F. Disinfecting Water Mains: The Contractor shall disinfect all water mains before the new facilities are placed into service. Disinfection must be performed in accordance with AWWA C651, latest revision and water samples must be submitted to a laboratory approved by the Texas Department of Health. Sample must be collected by the Contractor or his representative in the presence of the City or his representative. The Contractor shall be responsible for delivering the samples to an approved laboratory for testing. Sample results must indicate the facility is free of microbiological contamination before it is placed into service. It shall be the Contractor's responsibility to obtain a current copy of AWWA C651 to determine the correct forms of chlorine for disinfection, the basic disinfection procedure, preventive and corrective measures during construction, methods of chlorination, final flushing procedures, procedures for bacteriological tests, procedures for re-disinfection and disinfection procedures when cutting into existing mains. The Contractor, at its expense, will supply the concentrated chlorine disinfecting material, the City's personnel will supervise and direct the overall sterilization procedure. The Contractor, at his own expense, shall provide all other equipment, supplies and necessary labor to perform the sterilization under general supervision by the City.
- G. General
- 1. All valves shall be arranged to prevent the strong disinfecting dosage from flowing back into the existing water supply piping. The new pipeline shall then be completely filled with disinfecting solution by feeding the concentrated chlorine and approved water from the existing system uniformly into the new piping in such proportions that every part of the line has a minimum concentration of chlorine as prescribed in AWWA C651.
 - 2. Unless otherwise identified, all quantities called for herein refer to measurements by the testing procedures in the current edition of "Standard Methods of Examination of Water and Wastewater". The chlorine concentration of each step in the sterilization procedure shall be verified by chlorine residual determinations. This disinfecting solution shall be retained in the piping for at least twenty-four (24) hours, and all valves, hydrants, etc., shall be operated to disinfect all their parts. After this retention period, the water shall contain no less than the chlorine residual prescribed in AWWA C651 throughout the treated section of the pipeline.
 - 3. This heavily chlorinated water shall then be carefully flushed from the line until the chlorine concentration is not higher than the residual generally prevailing in the existing distribution system, or approximately 1.0 parts per million. Proper planning and appropriate preparations to handle, dilute and dispose of this strong chlorine solution without causing injury or damage to the public, the water system, the environment must be approved by the City before flushing of the line may begin, and the flushing shall be witnessed by an authorized representative of the City.

H. Bacteriological Testing

1. After final flushing of the strong disinfecting solution, water samples from the line shall be tested for bacteriological quality, at the Contractor's expense, and must be found free of coliform organisms before the pipeline may be placed in service. One (1) test sample shall be drawn from the end of the main and additional samples collected at intervals of not more than one-thousand (1,000) feet along the pipeline. A minimum of three (3) samples must be collected.
2. The Contractor, at his own expense, shall install sufficient sampling taps at proper locations along the pipeline. Each sampling tap shall consist of a standard corporation cock installed in the line and extended with a copper tubing gooseneck assembly. After samples have been collected, the gooseneck assembly shall be removed and retained for future use.
3. Samples for bacteriological analysis shall be collected only from suitable taps, in sterile bottles. Collection of the test samples shall be made in the presence of City personnel. If the initial disinfection fails to produce acceptable sample tests, the disinfection procedure shall be repeated (without extra compensation) until satisfactory test results have been obtained, before the piping may be placed in service.

CIP12.07 FINAL ACCEPTANCE

- A. No pipe installation will be accepted until all known leaks have been repaired whether or not leakage is within allowable limits. Locating and repairing of leaks shall be performed by the Contractor at no additional cost to the City.
- B. The City will certify that all required pressure and leakage tests have been successfully completed before the pipeline is accepted.

CIP12.08 PAYMENT

- A. No separate payment will be made for work completed in accordance with this specification, and the cost thereof will be included in the appropriate items of the Proposal and Bid Schedule.

END OF SECTION

TECHNICAL SPECIFICATIONS

SECTION CIP13 – SUMMARY OF TESTING (MISCELLANEOUS)

CIP13.01 SCOPE OF WORK

A. This specification covers the requirements to perform testing of various work items for this Project.

CIP13.02 SUBMITTALS

A. Within 30 days after the Notice to Proceed, the Contractor shall submit to the Engineer or the City for approval, technical product literature and all other pertinent data to illustrate conformance to the specification found within.

CIP13.03 TESTING FOR ROADS

Testing for roads shall be in accordance with Table 13-1.

Table 13-1

Item	Test Method	Passing Criteria	Comments
Hot Mix Asphaltic Concrete (HMAC)	Tex-200-F	See SD1.06 A	Sieve Analysis of Fine and Coarse Aggregate
	Tex-207-F	94.5%-97.5%Lab Density; 91.0%-96.0%In-PlaceField Density	Determining Density of Compacted Bituminous Mixtures
	Tex-210-F	See SD 1.06 B	Determining Asphalt Content of Bituminous Mixtures by Extraction
	Tex-227-F		Max. Specific Gravity of Bituminous Mixtures
	Tex-208-F	Min 35	Stability
Trench Backfill	Applicable Tex Testing Method	See Section G4.05	Minimum of one test every 250 linear feet of trench length for each lift.
Embankment	Tex-114-E	See Section SD3.06	Test every 2,000 SY of roadbed surface
Flexible Base	Tex-107-E, Part II Tex-411-A Tex-110-E	2% shrinkage	Bar Linear Shrinkage
	Tex-113-E	100% Density	Magnesium Soundness
	Tex-115-E		Sieve Analysis
	Tex-116-E	40 Max.	Moisture Density
	Tex-117-E	45 psi @ 0 psi lateral & 175 psi @ 15 psi lateral	Roadway Density
		Max. increase ≤ 20	Wet Ball Mill
	Tex-460-A	Plasticity Index ≤ 10	Triaxial Test (Part I or II)
	Tex-106-E	Liquid Limit ≤ 35	Particle Count (Part I)
	Tex-104-E	±2% Optimum	Plasticity Index
	Tex-103-E		Liquid Limit
		Moisture Content	

Table 13-1, cont.

Item	Test Method	Passing Criteria	Comments
Striping	Tex-828-B	10 or more stripes visible (day) 6 or more stripes visible (night) 0.060-inches minimum thickness for edgeline markings	Glass Beads: If criteria is not met, check Tex-828-B for scheduling replacement of striping. The average of the readings across each sample must be equal to or above the specified minimum thickness. No reading should be more than 10-mils below the specified minimum thickness.
	Tex-854-B	0.090-inches minimum thickness for stop bars, legends, symbols, gore and centerline/no passing barrier line markings 0.180-inches maximum thickness for all markings	

CIP13.04 TESTING FOR WATER/WASTEWATER

Testing for water/wastewater shall be in accordance with Table 13-2.

Table 13-2

Item	Test Method	Passing Criteria	Comments
Valves, Hydrants and Appurtenances	Manufacturer's Recommendations	Manufacturer's Recommendations	Functional field test of each valve, including actuators and valve control equipment.
Water and Wastewater Lines			As described in Section CIP 12: Testing of Pipelines

CIP13.05 TESTING FOR CONCRETE

Testing for concrete shall be in accordance with Table 13-3. Two (2) samples shall be tested for each truck load.

Table 13-3

Item	Test Method	Passing Criteria	Comments
Asphalt Board	Tex-524-C	Deflection from horizontal $1:3\frac{1}{2}$	
Concrete Slump	Tex-415-A		See Table 13-4 for Slump
Compressive Strength	Tex-418-A		See Table 4 in Section C-2
Flexural Strength	Tex-448-A		See Table 4 in Section C-2
Coarse Aggregate	Tex-413-A Tex-410-A Tex-411-A	0.25% by weight clay lumps 1.00% by weight shale 5.00% by weight laminated and/or friable particles 40% wear 12% loss Sodium Sulfate 18% loss Magnesium Sulfate	See Table 13-5 for Gradation Soundness Test

Table 13-3, cont.

Fine Aggregate	Tex-612-J	60% by weight acid insoluble residue subject to direct traffic. Color shall not be darker than Organic Color No. 3 (Gardner No. 11)	Color Test
	Tex-408-A		
Membrane Curing	Tex-401-F	Not less than 80 Between 2.3 & 3.1 for Non-Class K Between 2.6 & 2.8 for Class K	See Table 13-6 for Gradation Sand Equivalent Fineness Modulus
	Tex-203-F		
	Tex-402-A		
Membrane Curing	Tex-219-F	2% loss for 24-hour test 4% loss for 72-hour test	Water Retention Test

Table 13-4

Concrete Designation	Slump	Maximum Slump
1. All drill shaft	6	7
2. Uncased drill shafts, thin walled sections (<9") and pre-stressed concrete members	4	5
3. Slabs, caps, columns, piers, wall sections over 9", etc.	3	4
4. Underwater or seal concrete	6	7
5. Riprap, curb, gutter and other miscellaneous concrete.	As specified by City.	

Table 13-5

Aggregate Grade No.	Nominal Size (in)	Amount Retained (%)								
		2 1/2 in	2 in	1 1/2 in	1 in	3/4 in	1/2 in	3/8 in	No 4	No 8
1	2	0	0-20	15-50		60-80			95-100	
2 (467)*	1 1/2			0-5		30-65		70-90	95-100	
3	1 1/2			0-5		10-40	40-75		95-100	
4 (57)*	1				0-5		40-75		90-100	95-100
5 (67)*	1/4					0-10		45-80	90-100	95-100
6 (7)*	1/2							30-60	85-100	95-100
7	3/8							5-30	75-100	
8	3/8							0-5	35-80	90-100

Table 13-6

Aggregate Grade No.	Amount Retained (%)								
	3/8 in	No 4	No 8	No 16	No 30	No 50	No 100	No 200	
1	0	0-5	0-20	15-50	35-75	65-90	90-100	97-100	

CIP13.06 PAYMENT

- A. No separate payment will be made for work completed in accordance with this specification, and the cost thereof will be included in the appropriate items of the Proposal and Bid Schedule.

END OF SECTION

TECHNICAL SPECIFICATIONS

SECTION CIP14 – PROJECT CLOSEOUT

CIP14.01 SCOPE OF WORK

- A. This specification covers the administrative and procedural requirements for Project closeout, including but not limited to:
1. Closeout procedures.
 2. Final cleaning.
 3. Adjusting.
 4. Project record documents.
 5. Spare parts and maintenance materials.

CIP14.02 RECORD DOCUMENTS

- A. Maintain on site, one (1) set of the following documents; actual revisions to the Work shall be recorded in these documents:
1. Contract Drawings.
 2. Specifications.
 3. Addenda.
 4. Change Orders and other Modifications to the Contract.
 5. Reviewed shop drawings, product data, and samples.
- B. Store Record Documents separate from documents used for construction.
- C. Record information concurrent with construction progress.
- D. Specifications: Legibly mark and record at each Product section description of actual Products installed, including the following:
1. Manufacturer's name and product model and number.
 2. Product substitutions or alternates utilized.
 3. Changes made by Addenda and Modifications.
- E. Contract Drawings and Shop Drawings: Legibly mark each item to record actual construction including:
1. Measured depths of foundations in relation to finish floor datum.
 2. Measured horizontal and vertical locations of underground utilities and appurtenances, referenced to permanent surface improvements.
 3. Measured locations of internal utilities and appurtenances concealed in construction, referenced to visible and accessible features of the Work.
 4. Field changes of dimension and detail.
 5. Details not on original Contract Drawings.

- F. Submit documents to City with claim for final Application or Payment. Retention monies will not be released until complete record documents have been submitted.

CIP14.03

CLOSEOUT PROCEDURES

- A. Submit written certification that Contract Documents have been reviewed, Work has been inspected, and that Work is complete in accordance with Contract Documents and ready for Engineer's and/or City's inspection.
- B. Provide submittals to the City that are required by governing or other authorities.
- C. Submit final Application for Payment identifying total adjusted Contract Sum, previous payments, and sum remaining due.
- D. Submit three (3) sets of as-built drawings in digital and hard copy format.
- E. Reserved.

CIP14.04

FINAL CLEANING

- A. At the completion of work and immediately prior to final inspection, cleaning of the entire project shall be accomplished according to the following provisions:
 - 1. The Contractor shall thoroughly clean, sweep, wash, and polish all work and equipment provided under the Contract, including finishes. The cleaning shall leave the structures and site in a complete and finished condition to the satisfaction of the City.
 - 2. All Subcontractors shall similarly perform, at the same time, an equivalent thorough cleaning of all work and equipment provided under their contracts.
 - 3. The Contractor shall remove all temporary structures and all debris, including all dirt, sand, gravel, rubbish and waste material.
 - 4. Should the Contractor not remove rubbish or debris, or not clean the buildings and site as specified above, the City reserves the right to have the cleaning done at the expense of the Contractor.
- B. Use only cleaning materials recommended by manufacturer of surface to be cleaned.
- C. Use cleaning materials only on surfaces recommended by cleaning material manufacturers.
- D. In preparation for substantial completion or occupancy, conduct final inspection of sight-exposed interior and exterior surfaces, and of concealed spaces.
- E. Remove grease, dust, dirt, stains, labels, fingerprints, and other foreign materials from sight-exposed interior and exterior finished surfaces. Polish surfaces so designated to shine finish.
- F. Repair, patch, and touch up marred surfaces to specified finish, to match adjacent surfaces.
- G. Replace air-handling filters if units were operated during construction.
- H. Vacuum clean all interior spaces, including inside cabinets. Broom clean paved surfaces, mow any areas planted with grass which are in excess of two (2) inches high, and rake clean other surfaces of grounds.

- I. Handle materials in a controlled manner with as few handlings as possible. Do not drop or throw materials from heights.
- J. Schedule cleaning operations so that dust and other contaminants resulting from cleaning process will not fall on wet, newly-painted surfaces.

CIP14.05 ADJUSTING

- A. Adjust operating products and equipment to ensure smooth and unhindered operation.

CIP14.06 FINAL INSPECTION

- A. After final cleaning and restoration and upon written notice from the Contractor that the work is completed, the Engineer and/or City will make a preliminary inspection, with the Contractor present. Upon completion of this preliminary inspection, the Engineer and/or City will notify the Contractor, in writing, of any particulars in which this inspection reveals that the work is defective or incomplete.
- B. Upon receiving written notice from the Engineer and/or City, the Contractor shall immediately undertake the work required to remedy deficiencies and complete the work to the satisfaction of the City.
- C. When the Contractor has corrected or completed the items as listed in the Engineer's/ City's written notice, he/she shall inform the City in writing, that the required work has been completed. Upon receipt of this notice, the Engineer and/or City and the Contractor, will make the final inspection of the Project.
- D. Should the Engineer and/or City find all work satisfactory at the time of his inspection, the Contractor will be allowed to make application for final payment in accordance with the provisions of the Standard Form of Agreement. Should the Engineer and/or City still find deficiencies in the work, the Engineer and/or City will inform the Contractor of the deficiencies and will deny the Contractor's request for final payment until such time as the Contractor has satisfactorily completed the required work. Additional inspections of deficiencies shall be paid for by the Contractor at City's cost, but in no event will the cost be less than \$200.00 per inspection.

CIP14.07 ACCESSORY ITEMS

- A. The Contractor shall provide to the City, upon acceptance of the equipment, all special accessories required to place each item of equipment in full operation. These special accessory items include, but are not limited to, the specified spare parts, adequate oil and grease as required for the first lubrication of the equipment, initial fill-up of all chemical tanks and fuel tanks, light bulbs, fuses, hydrant wrenches, valve wrenches, valve keys, handwheels, and other expendable items as required for initial start-up and operation of all equipment.

CIP14.08 GUARANTEES, BONDS, AND AFFIDAVITS

- A. No application for final payment will be accepted until all guarantees, bonds, certificates, licenses, and affidavits required for work or equipment as specified in the Contract Documents are satisfactorily filed with the Engineer.

CIP14.09 RELEASE OF LIENS OR CLAIMS

- A. No application for final payment will be accepted until satisfactory evidence of release of liens has been submitted to the City as required by the Standard Form of Agreement.

CIP14.10

FINAL PAYMENT

- A. Final payment will be made to the Contractor in accordance with the General Conditions. Final payment and release of retention monies will not be made until the Contractor has submitted three (3) sets of as-built plans (digital and hard copy) to the City for the Project.

END OF SECTION

TECHNICAL SPECIFICATIONS

SECTION CIP15 – PROJECT IDENTIFICATION SIGNAGE

CIP15.01 SCOPE OF WORK

- A. This specification covers the requirements for furnishing, fabricating and erecting Project Signs on Capital Improvement Projects (C.I.P.) and for project identification at other construction sites, when required on the Plans or by the City.

CIP15.02 MATERIALS

- A. Sign Face: The sign face shall be manufactured on standard exterior waterproof plywood sheets or other suitable material approved by the Engineer or the City. Unless indicated otherwise on the Plans, the thickness of the plywood sheet shall be a minimum of ³/₄-inches.
- B. Posts: Plastic post, of the size indicated on the Plans, shall be pressure treated with pentachlorophenol.
- C. Paint: Exterior oil base paint shall be used and colors shall be as indicated on the Plans.
- D. Signs for Capital Improvements Projects: City seals shall be provided by the City.

CIP15.03 INSTALLATION

- A. The signs shall be erected at each major entrance to the project for maximum public identification and exposure. At locations where construction is confined to an adequate area defined by the City, the installed sign size shall be four-feet by eight-feet (4'x8'). At locations where roadway construction is in progress, such as a street paving or construction of a sidewalk, the sign shall be two-feet by three-feet (2'x3'). The signs shall be posted on portable wood frames or stanchions and will be located in the proximity of the work area as construction progresses. All lumber shall be painted with two (2) coats of paint as indicated on the Plans.
- B. In special cases, the size of the sign may be changed to meet special requirements, but general proportions shall be maintained.
- C. It shall be the responsibility of the Contractor to maintain and relocate signs, if necessary, during the progression of the project. Care shall be exercised to assure that placement of the signs does not interfere with or cause sight obstruction to vehicular and pedestrian traffic.
- D. The Contractor may install, at his own expense, company signs to identify the Contractor, Developer, etc. Signs are to be securely attached to the posts at locations indicated on the Plans and shall not be larger than 18-inches by 36-inches.

CIP15.04 PAYMENT

- A. No separate payment will be made for work performed in accordance with this section of the specifications, and the cost thereof shall be included in the proper items of the Proposal and Bid Schedule.

END OF SECTION

TECHNICAL SPECIFICATIONS

SECTION CIP16 – RESERVED

END OF SECTION

TECHNICAL SPECIFICATIONS

SECTION CIP17 – INSPECTION OF PROJECTS

CIP17.01 INSPECTION

- A. All Projects, whether by a private development or the City of Pflugerville shall be inspected by the City or a designated representative of the City.

- B. The time that the City of Pflugerville or its designated representative will be available for inspection is from 8:00 AM to Noon and 1:00 PM to 5:00 PM on working days. Working days shall be defined as Monday through Friday excluding all holidays observed by the City of Pflugerville. All inspections shall be scheduled with the City a minimum of two (2) working days prior to the inspection.

- C. If the Contractor, for his convenience and at his own expense, should desire to carry on his work at night or outside regular hours, he shall submit a written approval request, in accordance with **Section 3.1.4** of the General Conditions, to the City and, if authorized, he shall allow ample time for satisfactory arrangements to be made for inspecting the Work in progress. The Contractor shall also pay the expenses for extra inspection required for work outside regular hours at City’s actual cost, but in no event a rate of less than \$50.00/hour. Normal working hours are work hours occurring during the Work Week as defined in **Section 3.1.4** of the General Conditions. The Contractor shall light the different parts of the Project as required to comply with all applicable Federal and State regulations and with all applicable requirements of the City of Pflugerville.

CIP17.02 AUTHORITY AND DUTIES OF INSPECTORS

- A. Inspectors will be authorized to inspect all work done and all materials furnished. Such inspection may extend to all or to any part of the Work and to the preparation or Manufacturer of the materials to be used. Such inspection will not relieve the Contractor from any obligation to perform the Work in accordance with the requirements of the Specifications. In case of any dispute arising between the Contractor and the Inspector as to materials furnished or the manner of performing the Work, the Inspector will have authority to reject materials or suspend work until the question at issue can be referred to and decided by the City. The Inspector will not be authorized to revoke, alter, enlarge, or release any requirement of these Specifications, nor to approve or accept any portion of the Work, nor to issue instruction contrary to the Plans and Specifications. He will in no case act as foreman or perform other duties for the Contractor nor interfere with the management of the Work.

END OF SECTION

SECTION 13 02 00

Elevated Water Storage Tank Lighting Project

PART 1 - GENERAL

a) Summary of Work

i) Scope of Contract

- (1) The City of Pflugerville, Texas has a fifty-thousand-gallon riveted, lattice leg elevated water storage tank that is to be illuminated externally with lights under the terms of this contract. The work to be performed under these specifications includes the installation and procurement of the external lighting fixtures, the conduit and conductors for all power and controls necessary to energize and control the exterior lighting system and all connections necessary to attached all fixtures, conduit, and conductors to the elevated water storage tank.
- (2) The tank is located at 404 2nd St South, Pflugerville, TX 78660.
- (3) It shall be the responsibility of the bidders to carefully inspect the site and all pertinent parts and devices on the tank to ascertain the quantity of conduit and conductors for all power and controls necessary to energize and control the exterior lighting system in accordance with these contract specifications.

ii) Related Documents

Drawings and the general provisions of this document, including General Conditions, Supplemental Conditions, Special Provisions and other Division 1 Sections apply to work in this section.

b) References

The latest version of the following Specifications, Codes and Standards are incorporated by reference, including comments, recommendations, and best practices. This list is not exhaustive.

- i) National Fire Protection Association (NFPA)
NFPA-70, NEC – National Electrical Code
- ii) American Institute of Steel Construction (AISC)
S335 – Specification for Structural Steel Buildings
- iii) National Sanitation Foundation (NSF)
61 – Standard for Drinking Water System Components

iv) Occupational Safety and Health Administration (OSHA)
29 CFR 1926 – Safety and Health Regulations for Construction

v) Texas Commission on Environmental Quality (TCEQ)
Chapter 290 – Public Drinking Water

c) Submittals

The successful bidder shall reference City Standard Specs and Submittals below to submit to the Engineer prior to the start of work.

i) Construction Schedule

Submit a detailed schedule indicating anticipated start and completion dates for each major phase, including, but not limited to, conduit and conductor installation, lighting fixture installation, energize of lighting system.

Contractor shall update submitted schedule as needed.

ii) Schedule of Values

Submit a schedule of values which includes an itemized list of all work items and prices for each item of work.

iii) Contact Information

Submit contact information for all key field and office staff on the project including foreman and project manager.

iv) Subcontractor Information

If subcontractors will be used to perform any work under these specifications, submit contact information and references for the subcontractors. Provide the location, capacity, owner contact with phone number and year completed.

v) Welder Certifications

Submit certifications and welding procedures for all welders that will be performing work on the tank.

d) Guarantees

The Contractor shall guarantee the external lighting fixtures, the conduit and conductors for all power and controls necessary to energize and control the exterior lighting system and all connections necessary to attached all fixtures, conduit, and conductors to the elevated water storage tank provided under these specifications against defective design, workmanship or materials for a period of two years from the date of final completion. It shall be the responsibility of the Contractor to schedule and meet with the Engineer and inspect the tank exterior lighting system (11) months from the date of final acceptance to identify and correct all deficiencies

under the warranty.

All guarantees for materials and accessories provided under this section shall be obtained by the Contractor and submitted.

PART 2 – MATERIALS

a) Materials

i) Electrical and Lighting

(1) General

All work shall be performed and all materials shall be provided in accordance with National Electrical Code and the governing electrical, safety and inspection codes, regulations and ordinances.

(2) Materials

(a) Interior Lights

Not Required for this project.

(b) Exterior Lights

See Repair Items of Work.

PART 3 - EXECUTION

a) Welding

Welding procedures and general welding requirements shall be in accordance with AWWA D100, AWS Structural Welding Code D1.1, and these Specifications. All fillet welds shall be full fillet welds unless otherwise specified.

Grinding of weld contour shall approximate Condition “D” of NACE Standard SP0178

All welding repairs shall be completed before any paint is applied to the structure. All appurtenances, supports, and steel members shall be constructed of Type A36 mild carbon steel unless otherwise specified and be in accordance with AWWA D100, AISC 13th Edition, and TCEQ Chapter 290.

b) Repair Items of Work

- (1) Install four (4) exterior rated LED flood lights on balcony to illuminate City logo. Fixtures shall be enclosed and gasketed, 100 (one hundred) watt high pressure sodium wall mount type with aluminum base housing, polycarbonate cover, prismatic refractor, internal

reflector, and low temperature ballast. Fixture shall be vandal resistant and provided with photo control. Secure fixtures to balcony handrails with fiberglass tie wires. Exposed exterior conduit shall be PVC coated galvanized rigid steel, supported by PVC coated hardware with stainless steel fasteners. Submit catalog cut of lights and conduit to Engineer for approval. Minimum conduit size is 3/4".

(2) Install four (4) exterior rated LED flood lights on each leg of the tower to illuminate the tower in the upward direction. Fixtures shall be enclosed and gasketed, 100 (one hundred) watt high pressure sodium wall mount type with aluminum base housing, polycarbonate cover, prismatic refractor, internal reflector, and low temperature ballast. Fixture shall be vandal resistant and provided with photo control. Secure fixtures to balcony handrails with fiberglass tie wires. Exposed exterior conduit shall be PVC coated galvanized rigid steel, supported by PVC coated hardware with stainless steel fasteners. Submit catalog cut of lights and conduit to Engineer for approval. Minimum conduit size is 3/4".

(3) **Alternate Bid Item #1:** Provide additional pricing to install ten (10) ColorBlast Powercore gen4 LED flood lights on balcony to illuminate City Logo in lieu of above specified lighting. Secure fixtures to balcony handrails. Lights are to be programmable and capable to change color as desired by the city.

(a) Approved vendor for work is ERT Lighting of Austin,
Texas. (512) 419-9142

(4) **Alternate Bid Item #2:** Provide additional pricing to install four (4) ColorBlast Powercore gen4 LED flood lights on each leg of the tower to illuminate the tower in the upward direction in lieu of above specified lighting. Secure fixtures to the tower legs. Lights are to be programmable and capable to change color as desired by the city.

(a) Approved vendor for work is ERT Lighting of Austin,
Texas. (512) 419-9142

(5) **Alternate Bid Item #3:** Provide additional pricing for labor and materials for temporary installation of approved alternate lighting system for mock-up test to determine quantity of balcony and leg lights. Mock-up test lights will be ColorBlast Powercore gen4 LED flood lights. Two (2) test lights, one (1) each on two adjacent legs of the tower to illuminate the tower in the upward direction. Two (2) test lights on the balcony of the tower to illuminate the logo of the tower in the upward direction. The two (2) balcony test lights shall be separated at a distance to replicate the spacing of ten (10) lights on the balcony. Secure fixtures to the tower legs. Lights are to be programmable and capable to change color as desired by the city.

(a) Approved vendor for work is ERT Lighting of Austin,
Texas. (512) 419-9142

(b) Other Vendors, or equal, may be considered but shall be approved by the Engineer prior to the Submittal of Bid.

(6) **Alternate Bid Item #4:** Provide additional pricing to install one (1) ColorBlast Powercore gen4 LED flood light on a leg or the balcony of the tower to illuminate the tower in the upward direction in lieu of above specified lighting. Secure fixtures to the tower legs. Lights are to be programmable and capable to change color as desired by the city.

(a) Approved vendor for work is ERT Lighting of Austin, Texas. (512) 419-9142

(b) Other Vendors, or equal, may be considered but shall be approved by the Engineer prior to the Submittal of Bid.

c) Coating Repair Procedure

If coating repairs are required for any reason, the repairs shall be made in a manner that will not damage surrounding coated surfaces. The area to be repaired shall be free of rust, dirt, oil, grease, moisture, and other foreign material prior to coating application. The surrounding coating shall be feathered to eliminate sharp edges. The repaired coating shall be applied and inspected in the same manner as specified above. All requirements of the coating specifications shall apply to coating repairs.

d) Cleanup

Upon completion of all work, the Contractor shall remove all surface materials and rubbish and dispose of them in accordance with directions of the Engineer. The Contractor shall repair all damage caused by his workers and shall leave the premises in a clean and orderly condition equal to that of when he found it.

e) Inspection

i) General

The Engineer's Field Representative will perform quality assurance inspections on the Contractor's work on a hold-point basis. The Contractor is required to perform his own quality control.

No work will progress beyond the designated hold-point until approved by the Engineer's Field Representative.

The Contractor is required to coordinate with the inspector and provide 24-hour notice to request a hold-point inspection. Hold-point inspections shall NOT be scheduled during weekends or Federal Holidays.

The Contractor shall submit daily weather and progress reports, including anticipated work schedule for the next 7 days, to Engineer and Engineer's Field Representative via email.

The Contractor is responsible for providing safe rigging to gain access to all work areas to be

inspected. All rigging must conform to OSHA Standard 1910.

The Contractor is responsible for providing recommended lighting per SSPC Technology Guide 12 to illuminate the work and inspection areas.

If the Contractor does not provide adequate lighting or safe rigging to properly inspect the work, the inspection will be postponed until such time as the Engineer can schedule an inspection to determine if the work may progress beyond the hold-point.

ii) Hold Points

The following hold-points are designated:

- Field location of conduit/conductor runs
- Field location of lighting fixtures
- Inspection of completed installation of conduit/conductor runs
- Inspection of completed installation of lighting fixtures
- Energization of lighting system (Performed at night)
- Final inspection of lighting system

END OF SECTION

Pflugerville, TX Historic Water Tower Blast

Pflugerville, TX Historic Water Tower

Photometric Rendering - Gray Scale



Notes:

- The 3D model is a simplified version of the actual building.
- Renderings are for conceptual purposes only.
- Mockup is recommended to ensure design intent is met.
- Renderings show luminance, the amount of light hitting a surface. Actual appearance and brightness depends on the reflectance of the material.

Pflugerville, TX Historic Water Tower

Photometric Rendering - Pseudo Color

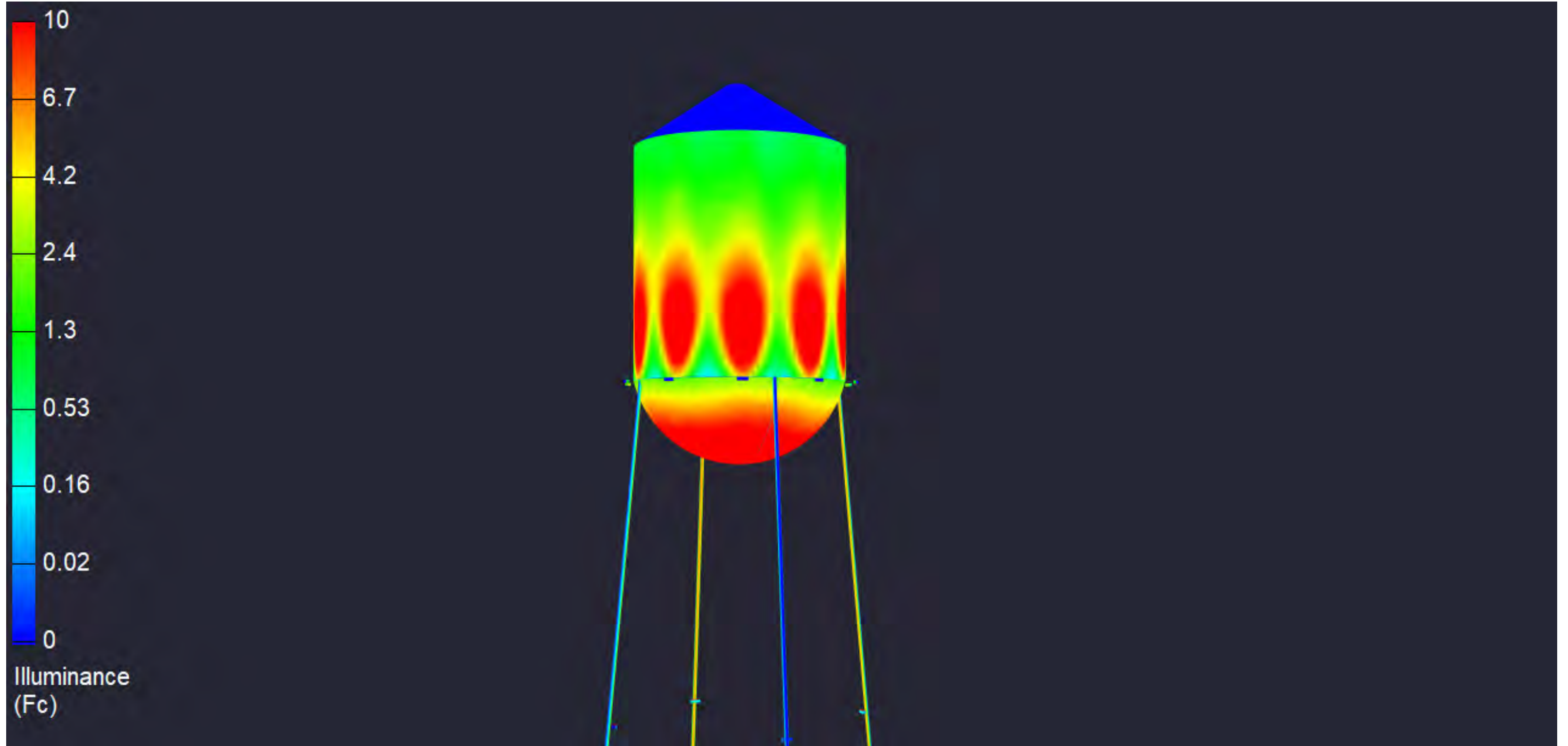

Notes:

- The 3D model is a simplified version of the actual building.
- Renderings are for conceptual purposes only.
- Mockup is recommended to ensure design intent is met.
- Renderings show luminance, the amount of light hitting a surface. Actual appearance and brightness depends on the reflectance of the material.

Pflugerville, TX Historic Water Tower

Conceptual Renderings

Sunset Gradient



Blue and Green Gradient



- Notes:
- Renderings are for conceptual purposes only.
 - Mockup is recommended to ensure design intent is met.
 - Renderings show luminance, the amount of light hitting a surface. Actual appearance and brightness depends on the reflectance of the material.
 - Antennas shown are have been removed from the tower.

Pflugerville, TX Historic Water Tower

Conceptual Renderings

Rainbow Gradient



Pink



Notes:

- Renderings are for conceptual purposes only.
- Mockup is recommended to ensure design intent is met.
- Renderings show luminance, the amount of light hitting a surface. Actual appearance and brightness depends on the reflectance of the material.
- Antennas shown are have been removed from the tower.

A2



Alternate Bid Item #1 (10 lights on catwalk)
Alternate Bid Item #2 (4 lights on legs)



Alternate Bid Item #1 (10 lights on catwalk)
Alternate Bid Item #2 (4 lights on legs)



Alternate Bid Item #1 (10 lights on catwalk)



Example Balcony Light Mock-Up Test (Alternate Bid Item #3)

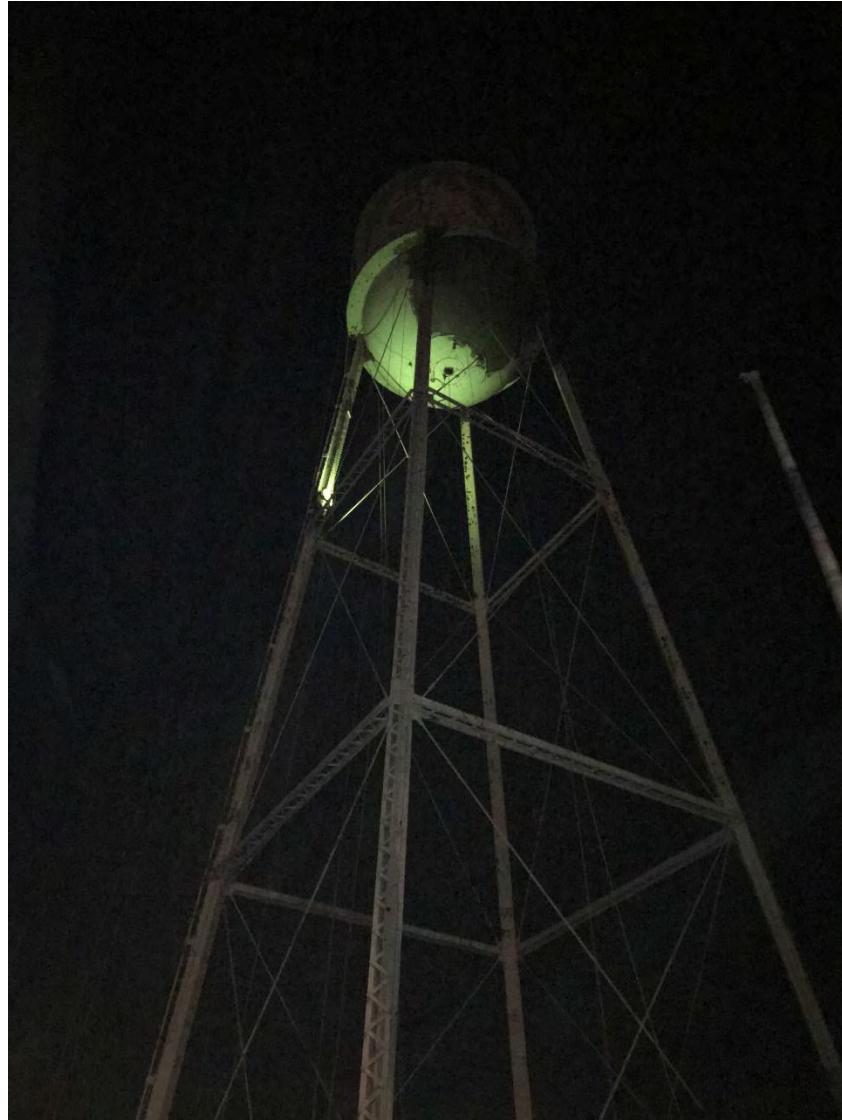

Example Leg Light Mock-Up Test (Alternate Bid Item #4)

Revision Schedule

Revision Number	Revision Description	Revision Date

CITY OF PFLUGERVILLE
HISTORIC EST
LIGHTING PROJECT

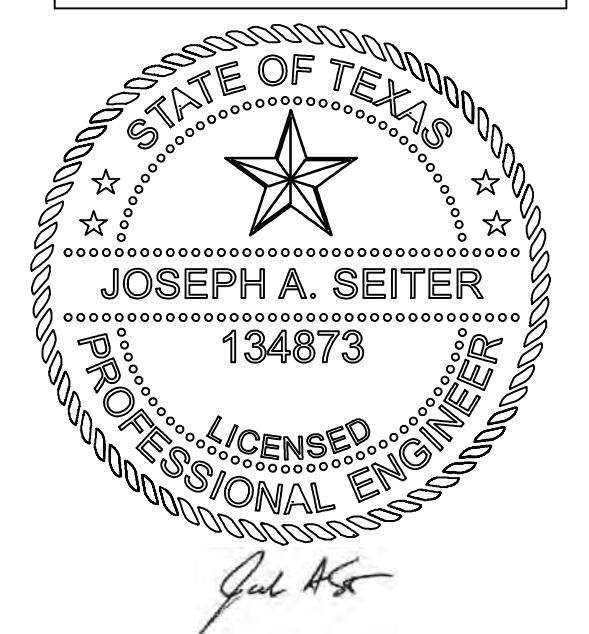

02/16/2024



6102 IMPERIAL LOOP DR.
COLLEGE STATION,
TEXAS 77845
PHONE 979-690-6555
TX FIRM NO.
F-22537

TOWER &
SITE PLAN

SHEET A3: 1 OF 1

Date: 02/16/2024

Project No: 27500454

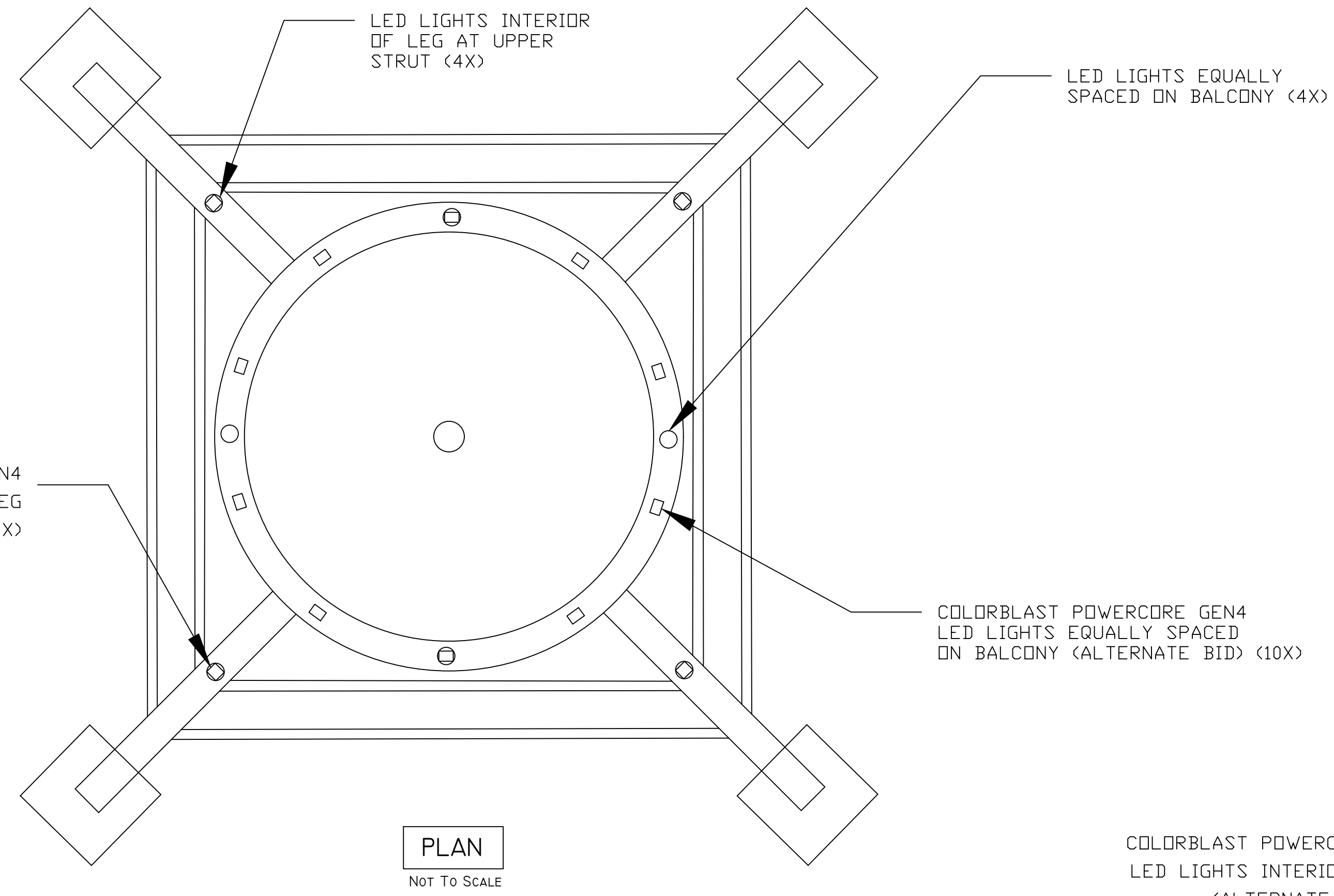

PLAN
NOT TO SCALE

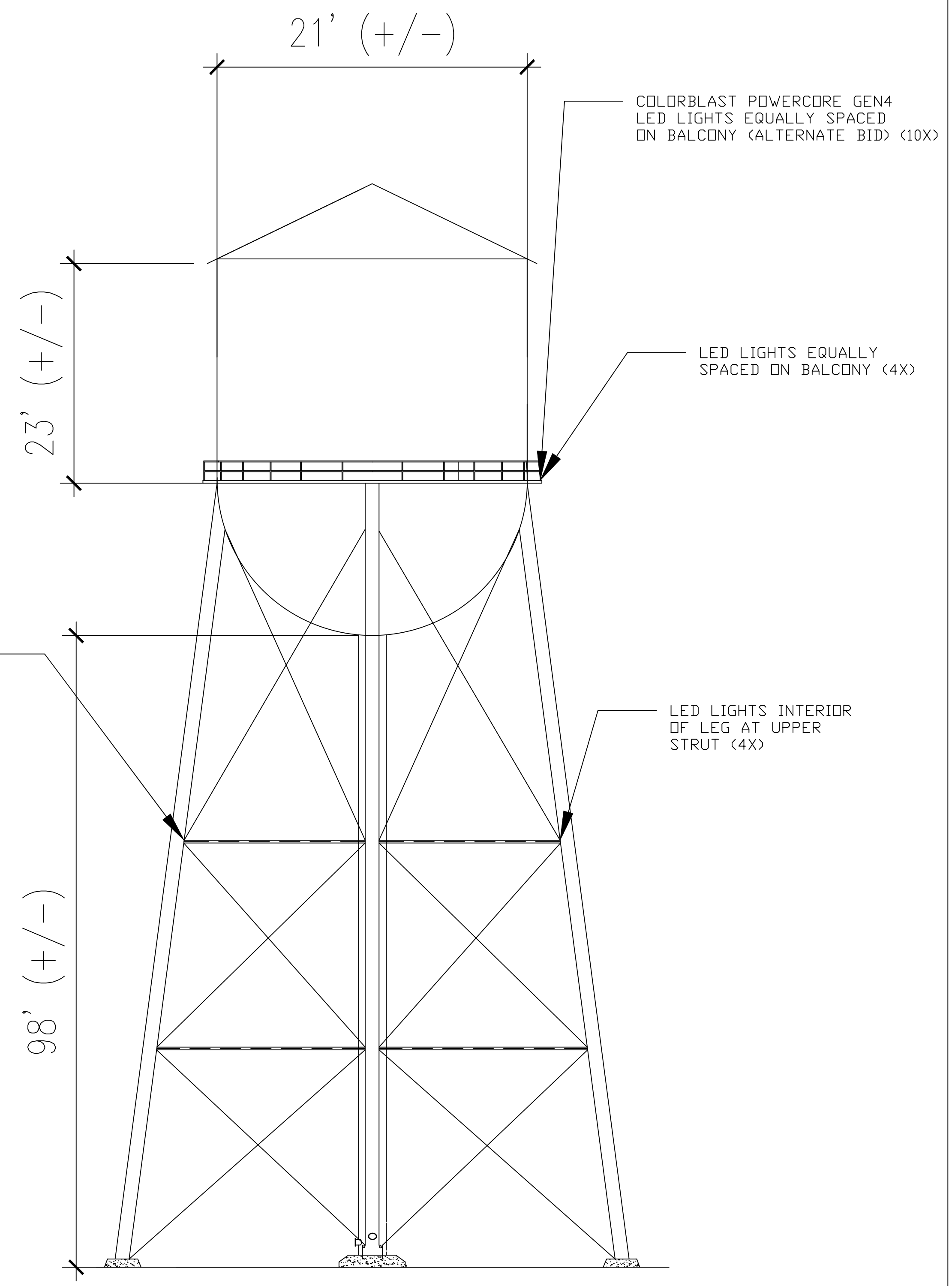

ELEVATION
NOT TO SCALE

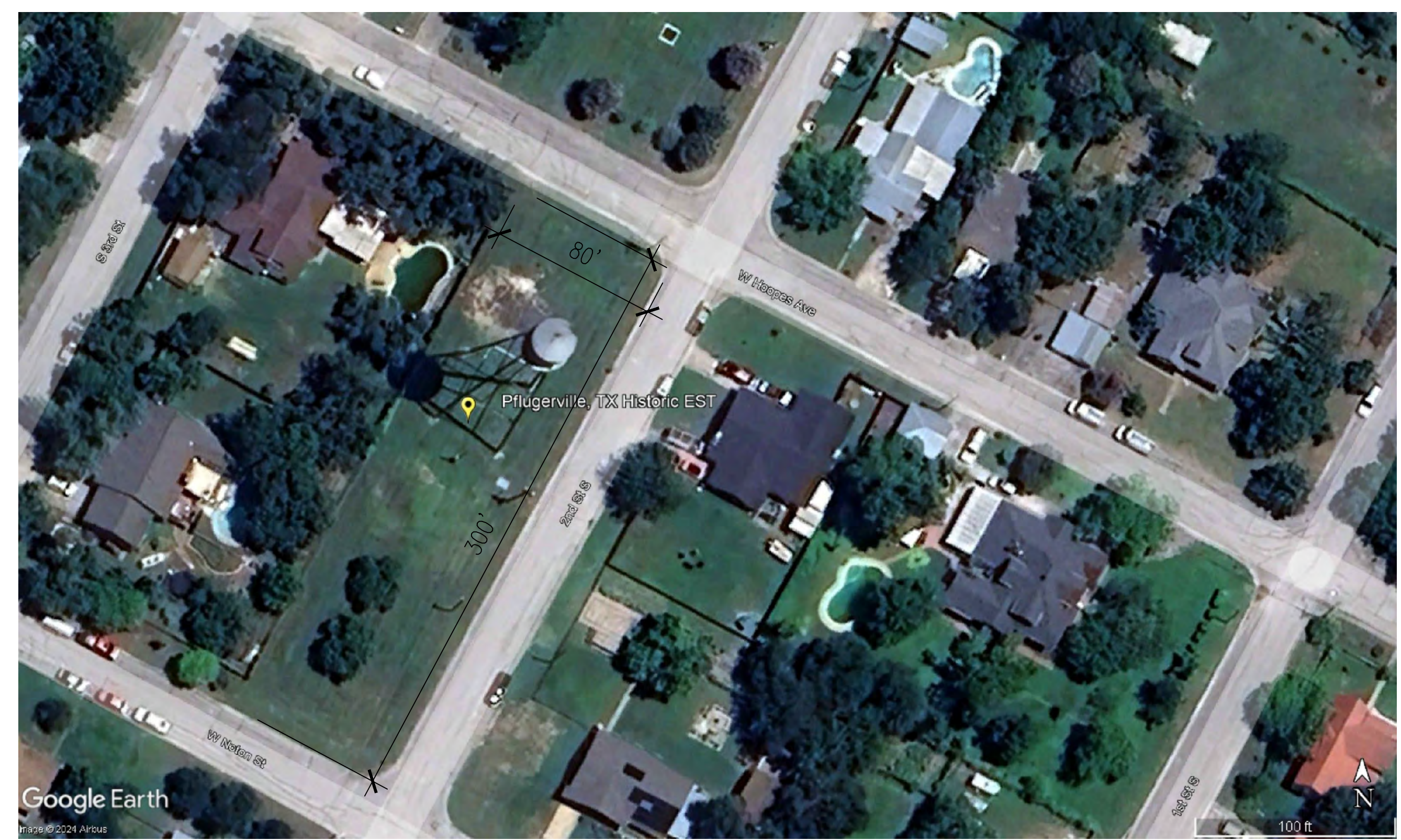

Maps to Site
City of Pflugerville
Historic Elevated Water Storage Tank
Located at approximately 400 2nd Street South, Pflugerville TX 78660
GPS Coordinates: 30°26'15.9"N, 97°37'25.1"W



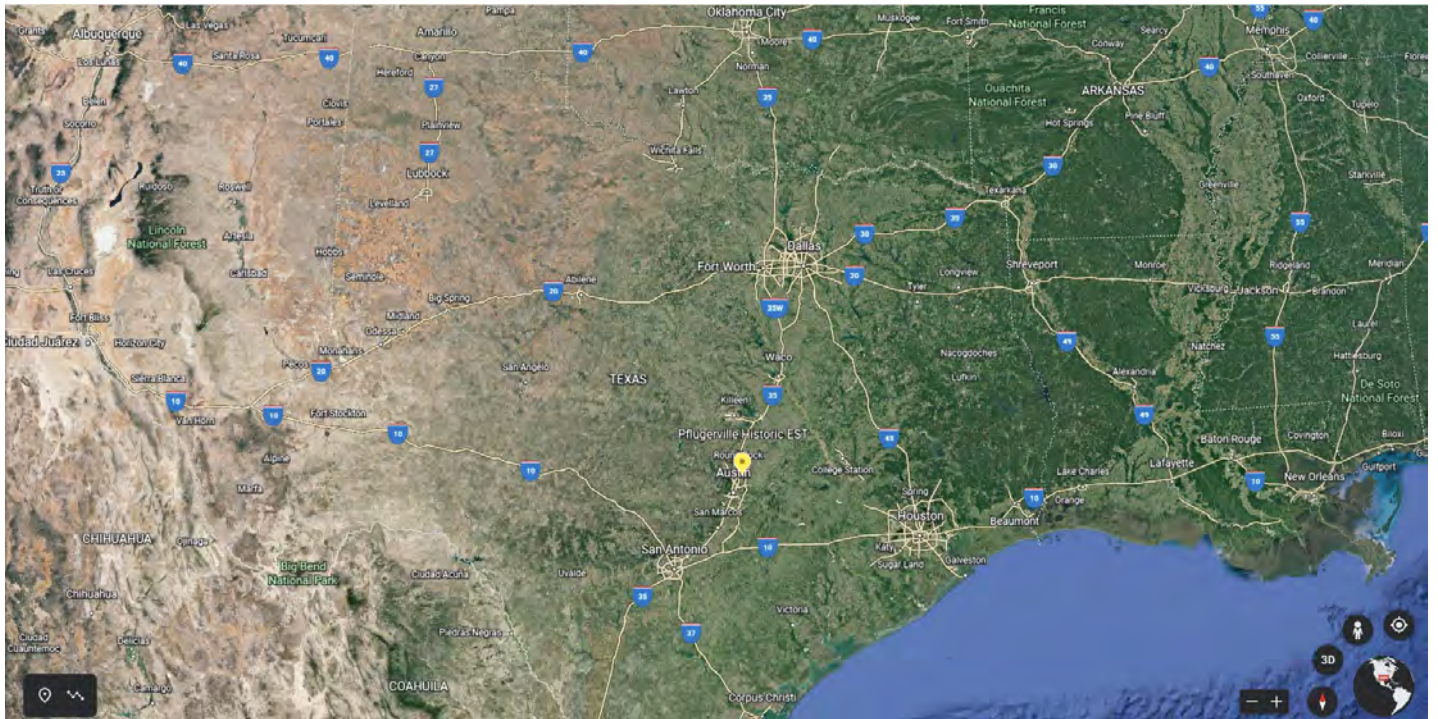
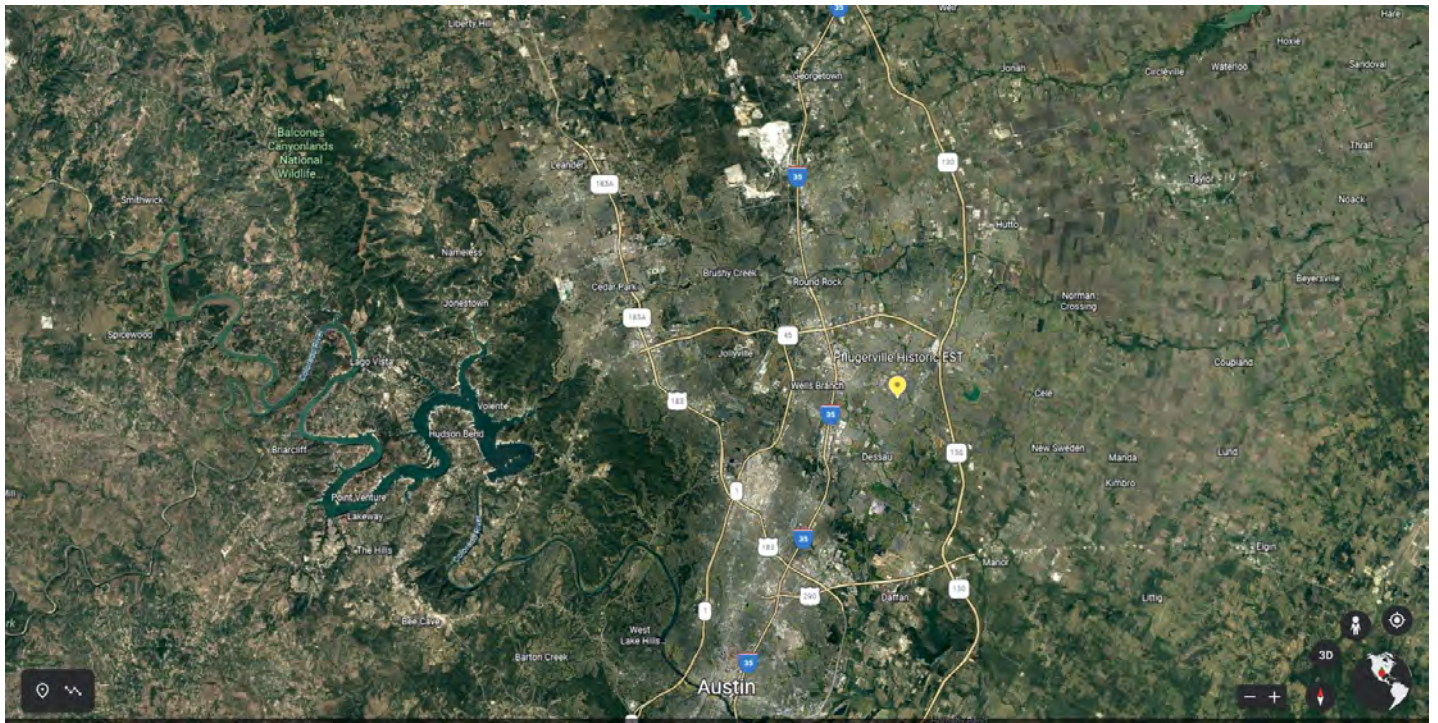



Field Inspection Report
Dunham Engineering TX F-22537
(979) 690-6555

Tank ID: Pflugerville Historic EST Pre-Rehab
Owner: City of Pflugerville
Inspector: Wesley Oatman, P.E., Dalton Warren,
E.I.T., and Rachel Schober, E.I.T.
Date of Inspection: 07/29/2022
Tank Description: 50,000 Gallon Riveted EST

Overview Map

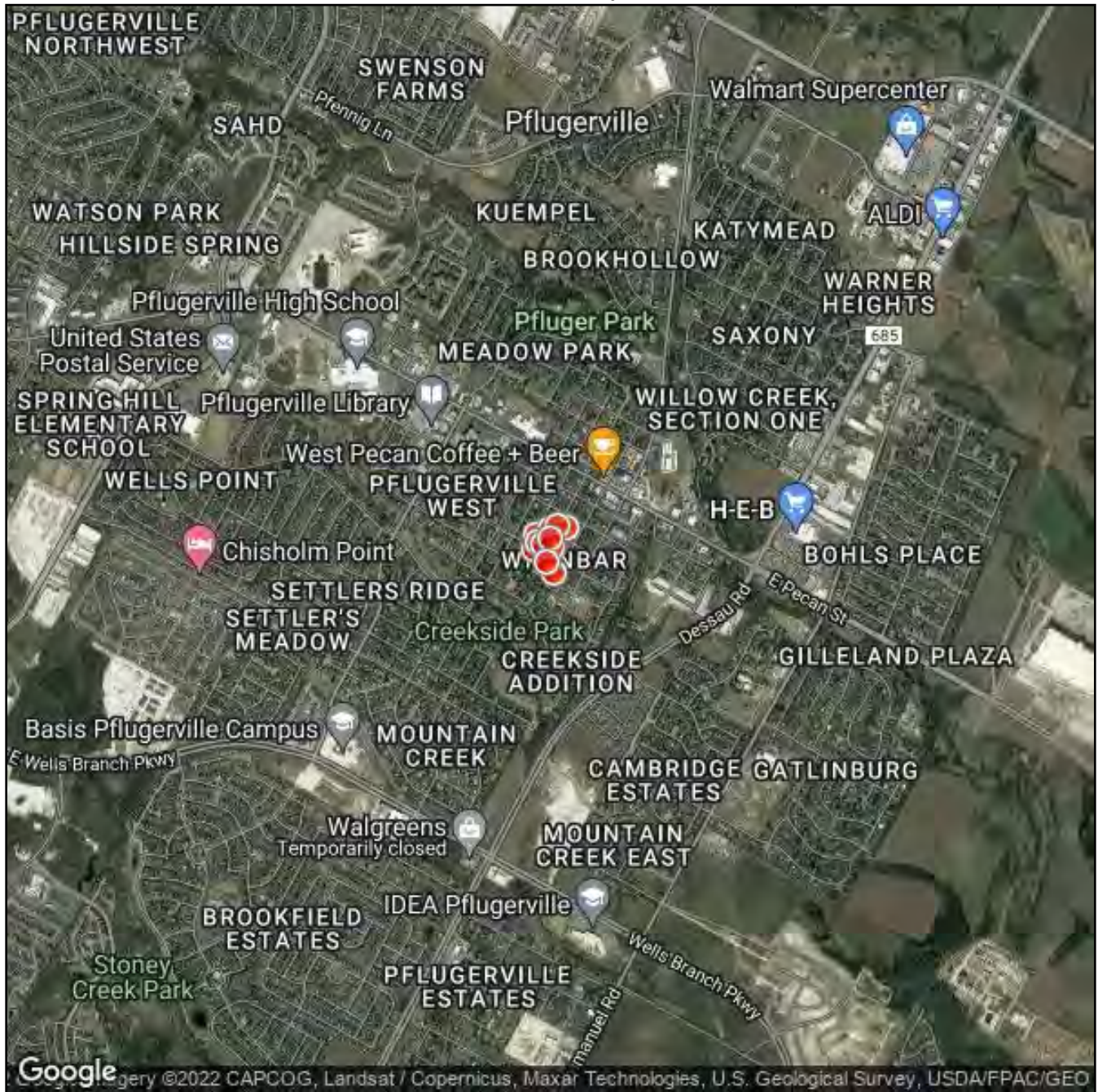



Attributes	
Title	Pflugerville Historic EST
Inspection Item	Overview
Condition	Acceptable
Notes/Dimensions	<p>This is a 50,000-gallon lattice-leg elevated storage tank that was built by Pittsburg Des Moines Steel Co. The date of construction could not be determined at the time of inspection. The tank is approximately 139' tall with a diameter of approximately 19'.</p> <p>The tank is in overall fair structural condition. The interior and exterior protective coating systems are at the end of their useful life and should be replaced. The coatings do not provide adequate corrosion protection.</p> <p>See report below for more information.</p>
Inspector	Wesley Oatman, P.E., Dalton Warren, E.I.T., & Rachel Schober, E.I.T.



Attributes	
Title	Pflugerville Historic EST
Inspection Item	Site and Fencing
Condition	Acceptable
Notes/Dimensions	There is no security fencing present on three sides of the property.
Inspector	Wesley Oatman, P.E., Dalton Warren, E.I.T., & Rachel Schober, E.I.T.



Attributes	
Title	Pflugerville Historic EST
Inspection Item	Site and Fencing
Condition	Acceptable
Notes/Dimensions	The West side of the site has a security fence between the neighboring residential properties.
Inspector	Wesley Oatman, P.E., Dalton Warren, E.I.T., & Rachel Schober, E.I.T.



Attributes	
Title	Pflugerville Historic EST
Inspection Item	Site and Fencing
Condition	Acceptable
Notes/Dimensions	The West side of tank has approximately 15' of clearance to the fence.
Inspector	Wesley Oatman, P.E., Dalton Warren, E.I.T., & Rachel Schober, E.I.T.



Attributes	
Title	Pflugerville Historic EST
Inspection Item	Site and Fencing
Condition	Acceptable
Notes/Dimensions	The South side of the tank has approximately 12' of clearance to the power lines along the road.
Inspector	Wesley Oatman, P.E., Dalton Warren, E.I.T., & Rachel Schober, E.I.T.



Attributes	
Title	Pflugerville Historic EST
Inspection Item	Site and Fencing
Condition	Acceptable
Notes/Dimensions	There is an electrical service pole adjacent to the tank.
Inspector	Wesley Oatman, P.E., Dalton Warren, E.I.T., & Rachel Schober, E.I.T.



Attributes	
Title	Pflugerville Historic EST
Inspection Item	Site and Fencing
Condition	Acceptable
Notes/Dimensions	The South side of the tank has approximately 12' of clearance to the power lines along the road.
Inspector	Wesley Oatman, P.E., Dalton Warren, E.I.T., & Rachel Schober, E.I.T.



Attributes	
Title	Pflugerville Historic EST
Inspection Item	Exterior Coating
Condition	Unacceptable
Notes/Dimensions	The exterior coating is no longer providing adequate corrosion protection due to delamination.
Inspector	Wesley Oatman, P.E., Dalton Warren, E.I.T., & Rachel Schober, E.I.T.



Attributes	
Title	Pflugerville Historic EST
Inspection Item	ASTM D3359 Adhesion Test
Condition	Acceptable
Notes/Dimensions	The adhesion test was conducted on one of the legs at ground level and resulted in Grade 3A. The tank is not recommended for overcoating due to delamination.
Inspector	Wesley Oatman, P.E., Dalton Warren, E.I.T., & Rachel Schober, E.I.T.



Attributes	
Title	Pflugerville Historic EST
Inspection Item	Data Plate
Condition	Acceptable
Notes/Dimensions	The tank has a data plate present at the base of the ladder leg. No date could be found on the data plate.
Inspector	Wesley Oatman, P.E., Dalton Warren, E.I.T., & Rachel Schober, E.I.T.



Attributes	
Title	Pflugerville Historic EST
Inspection Item	Foundation
Condition	Acceptable
Notes/Dimensions	All foundations are level with no signs of uneven settlement, excessive cracking, or spalling.
Inspector	Wesley Oatman, P.E., Dalton Warren, E.I.T., & Rachel Schober, E.I.T.



Attributes	
Title	Pflugerville Historic EST
Inspection Item	Anchor Bolts
Condition	Unacceptable
Notes/Dimensions	There are two anchor bolts per leg for a total of 8. There is minor corrosion damage noted on the anchor bolts at the base plate interface.
Inspector	Wesley Oatman, P.E., Dalton Warren, E.I.T., & Rachel Schober, E.I.T.



Attributes	
Title	Pflugerville Historic EST
Inspection Item	Anchor Bolts
Condition	Unacceptable
Notes/Dimensions	There are two anchor bolts per leg for a total of 8. There is minor corrosion damage noted on the anchor bolts at the base plate interface.
Inspector	Wesley Oatman, P.E., Dalton Warren, E.I.T., & Rachel Schober, E.I.T.



Attributes	
Title	Pflugerville Historic EST
Inspection Item	Riser Pipe
Condition	Acceptable
Notes/Dimensions	The nominal 8" diameter riser pipe is plumb.
Inspector	Wesley Oatman, P.E., Dalton Warren, E.I.T., & Rachel Schober, E.I.T.



Attributes	
Title	Pflugerville Historic EST
Inspection Item	Water Level Indicator and Sample Port
Condition	Acceptable
Notes/Dimensions	The riser pipe is equipped with a level gauge and sample port.
Inspector	Wesley Oatman, P.E., Dalton Warren, E.I.T., & Rachel Schober, E.I.T.



Attributes	
Title	Pflugerville Historic EST
Inspection Item	Pulley System
Condition	Unacceptable
Notes/Dimensions	There are two pulley systems attached to each leg. The one pictured on the right is not operational due to a broken wire.
Inspector	Wesley Oatman, P.E., Dalton Warren, E.I.T., & Rachel Schober, E.I.T.



Attributes	
Title	Pflugerville Historic EST
Inspection Item	Electrical Conduit
Condition	Acceptable
Notes/Dimensions	There is an electrical conduit running up the tank leg opposite the ladder leg.
Inspector	Wesley Oatman, P.E., Dalton Warren, E.I.T., & Rachel Schober, E.I.T.



Attributes	
Title	Pflugerville Historic EST
Inspection Item	Electrical Service
Condition	Acceptable
Notes/Dimensions	There are electrical service boxes mounted to the base of the legs.
Inspector	Wesley Oatman, P.E., Dalton Warren, E.I.T., & Rachel Schober, E.I.T.



Attributes	
Title	Pflugerville Historic EST
Inspection Item	Electrical Wiring
Condition	Unacceptable
Notes/Dimensions	The electrical conduit mounted behind the ladder is a climbing hazard. The nominal 3" pipe runs up the side of the tank.
Inspector	Wesley Oatman, P.E., Dalton Warren, E.I.T., & Rachel Schober, E.I.T.



Attributes	
Title	Pflugerville Historic EST
Inspection Item	Legs
Condition	Acceptable
Notes/Dimensions	The legs are constructed of 12"x3"x3/8" channel and are in good structural condition.
Inspector	Wesley Oatman, P.E., Dalton Warren, E.I.T., & Rachel Schober, E.I.T.



Attributes	
Title	Pflugerville Historic EST
Inspection Item	Lattice
Condition	Acceptable
Notes/Dimensions	The lattices are constructed of 19" x 2 1/4" x 3/8" flat bar and are in good condition.
Inspector	Wesley Oatman, P.E., Dalton Warren, E.I.T., & Rachel Schober, E.I.T.



Attributes	
Title	Pflugerville Historic EST
Inspection Item	Valve Vault
Condition	Acceptable
Notes/Dimensions	There is a valve vault adjacent to the tank that measures 4' wide x 6' long x 5'-3" deep.
Inspector	Wesley Oatman, P.E., Dalton Warren, E.I.T., & Rachel Schober, E.I.T.



Attributes	
Title	Pflugerville Historic EST
Inspection Item	Valve Vault
Condition	Acceptable
Notes/Dimensions	There is a nominal 8" gate valve and line in the bottom of the vault.
Inspector	Wesley Oatman, P.E., Dalton Warren, E.I.T., & Rachel Schober, E.I.T.



Attributes	
Title	Pflugerville Historic EST
Inspection Item	Exterior Coating
Condition	Acceptable
Notes/Dimensions	The exterior coating measured an average of 4.239 mils DFT at grade.
Inspector	Wesley Oatman, P.E., Dalton Warren, E.I.T., & Rachel Schober, E.I.T.



Attributes	
Title	Pflugerville Historic EST
Inspection Item	Access Ladder and Climb Prevention Door
Condition	Unacceptable
Notes/Dimensions	The access ladder is not OSHA compliant. The bottom climb prevention door was operational with a lock. The top climb prevention door was not locked at the time of the inspection. There are several bent rungs intermittently up the length of the ladder. The ladder is equipped with a tubular style safety climb device.
Inspector	Wesley Oatman, P.E., Dalton Warren, E.I.T., & Rachel Schober, E.I.T.



Attributes	
Title	Pflugerville Historic EST
Inspection Item	1st Strut Level
Condition	Unacceptable
Notes/Dimensions	The struts are constructed of two 7" x 2" x 3/8" channel. There is an area of moderate corrosion damaged noted on the top channel. All struts of the first level appear to have been replaced, and not original.
Inspector	Wesley Oatman, P.E., Dalton Warren, E.I.T., & Rachel Schober, E.I.T.



Attributes	
Title	Pflugerville Historic EST
Inspection Item	1st Strut Level
Condition	Unacceptable
Notes/Dimensions	There is approximately a 6' section of moderate corrosion and holes on the strut.
Inspector	Wesley Oatman, P.E., Dalton Warren, E.I.T., & Rachel Schober, E.I.T.



Attributes	
Title	Pflugerville Historic EST
Inspection Item	1st Strut Level
Condition	Acceptable
Notes/Dimensions	The struts are structurally sound, and all sway rods appear tight.
Inspector	Wesley Oatman, P.E., Dalton Warren, E.I.T., & Rachel Schober, E.I.T.



Attributes	
Title	Pflugerville Historic EST
Inspection Item	2nd Strut Level
Condition	Acceptable
Notes/Dimensions	The struts are structurally sound, and all sway rods appear tight. Three of the four struts on this level appear to be original.
Inspector	Wesley Oatman, P.E., Dalton Warren, E.I.T., & Rachel Schober, E.I.T.



Attributes	
Title	Pflugerville Historic EST
Inspection Item	2nd Strut Level
Condition	Acceptable
Notes/Dimensions	The struts are structurally sound, and all sway rods appear tight.
Inspector	Wesley Oatman, P.E., Dalton Warren, E.I.T., & Rachel Schober, E.I.T.



Attributes	
Title	Pflugerville Historic EST
Inspection Item	Riser Pipe to Bowl Connection
Condition	Acceptable
Notes/Dimensions	The bowl is in good structural condition. There is localized corrosion on the riser to bowl connection
Inspector	Wesley Oatman, P.E., Dalton Warren, E.I.T., & Rachel Schober, E.I.T.



Attributes	
Title	Pflugerville Historic EST
Inspection Item	Overflow Pipe and Flap Valve
Condition	Unacceptable
Notes/Dimensions	The nominal 4" diameter overflow pipe is in good condition. The flap valve does not properly seat to comply with TCEQ regulations.
Inspector	Wesley Oatman, P.E., Dalton Warren, E.I.T., & Rachel Schober, E.I.T.



Attributes	
Title	Pflugerville Historic EST
Inspection Item	Antenna
Condition	Acceptable
Notes/Dimensions	There are three antennas and lights mounted to the balcony handrail.
Inspector	Wesley Oatman, P.E., Dalton Warren, E.I.T., & Rachel Schober, E.I.T.



Attributes	
Title	Pflugerville Historic EST
Inspection Item	Balcony, Handrails and Sidewall
Condition	Acceptable
Notes/Dimensions	The balcony measures 24" wide and the handrails measure 36" tall.
Inspector	Wesley Oatman, P.E., Dalton Warren, E.I.T., & Rachel Schober, E.I.T.



Attributes	
Title	Pflugerville Historic EST
Inspection Item	Manual Liquid Level Indicator
Condition	Unacceptable
Notes/Dimensions	The manual liquid level indicator is not functional.
Inspector	Wesley Oatman, P.E., Dalton Warren, E.I.T., & Rachel Schober, E.I.T.



Attributes	
Title	Pflugerville Historic EST
Inspection Item	Exterior Coating
Condition	Acceptable
Notes/Dimensions	The exterior coating measures an average 6.209 mils DFT at the shell wall.
Inspector	Wesley Oatman, P.E., Dalton Warren, E.I.T., & Rachel Schober, E.I.T.



Attributes	
Title	Pflugerville Historic EST
Inspection Item	Antenna
Condition	Acceptable
Notes/Dimensions	There are three antennas and lights mounted to the balcony handrail.
Inspector	Wesley Oatman, P.E., Dalton Warren, E.I.T., & Rachel Schober, E.I.T.



Attributes	
Title	Pflugerville Historic EST
Inspection Item	Antenna
Condition	Acceptable
Notes/Dimensions	There are three antennas and lights mounted to the balcony handrail.
Inspector	Wesley Oatman, P.E., Dalton Warren, E.I.T., & Rachel Schober, E.I.T.



Attributes	
Title	Pflugerville Historic EST
Inspection Item	Access Ladder, Balcony to Roof
Condition	Unacceptable
Notes/Dimensions	The roof access ladder is not OSHA compliant. The antennas do not maintain a 3" clear spacing around the ladder rails which creates a climbing hazard. The ladder is equipped with a tubular style safety climb.
Inspector	Wesley Oatman, P.E., Dalton Warren, E.I.T., & Rachel Schober, E.I.T.

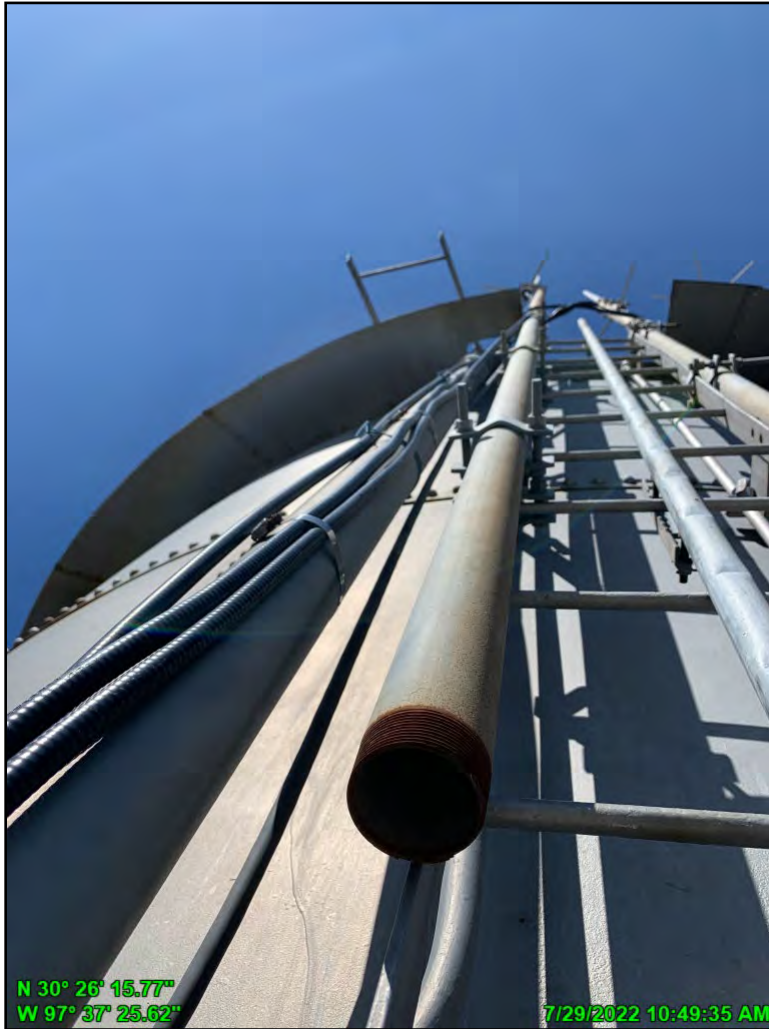

Attributes	
Title	Pflugerville Historic EST
Inspection Item	Coaxial Cables
Condition	Acceptable
Notes/Dimensions	There are coaxial cables mounted to the 3" diameter pipe.
Inspector	Wesley Oatman, P.E., Dalton Warren, E.I.T., & Rachel Schober, E.I.T.



Attributes	
Title	Pflugerville Historic EST
Inspection Item	Obstruction Light
Condition	Unacceptable
Notes/Dimensions	The obstruction light did not appear operational and was missing a globe.
Inspector	Wesley Oatman, P.E., Dalton Warren, E.I.T., & Rachel Schober, E.I.T.



Attributes	
Title	Pflugerville Historic EST
Inspection Item	Roof Ladder
Condition	Unacceptable
Notes/Dimensions	The roof rolling ladder is wired to one of the antenna posts. The ladder is equipped with a tubular style safety climb device.
Inspector	Wesley Oatman, P.E., Dalton Warren, E.I.T., & Rachel Schober, E.I.T.



Attributes	
Title	Pflugerville Historic EST
Inspection Item	Interior Coating
Condition	Unacceptable
Notes/Dimensions	The interior coating has completely failed and no longer provides adequate corrosion protection.
Inspector	Wesley Oatman, P.E., Dalton Warren, E.I.T., & Rachel Schober, E.I.T.



Attributes	
Title	Pflugerville Historic EST
Inspection Item	Roof Structure
Condition	Unacceptable
Notes/Dimensions	There are missing J-bolts at the roof to shell connection.
Inspector	Wesley Oatman, P.E., Dalton Warren, E.I.T., & Rachel Schober, E.I.T.



Attributes	
Title	Pflugerville Historic EST
Inspection Item	Spider Ring
Condition	Acceptable
Notes/Dimensions	The spider ring is in good condition.
Inspector	Wesley Oatman, P.E., Dalton Warren, E.I.T., & Rachel Schober, E.I.T.



Attributes	
Title	Pflugerville Historic EST
Inspection Item	Auxiliary Fill Pipe
Condition	Unacceptable
Notes/Dimensions	The nominal 3" diameter pipe terminates at the top of the shell with a PVC coupling. There is a deteriorated screen over the opening in the shell.
Inspector	Wesley Oatman, P.E., Dalton Warren, E.I.T., & Rachel Schober, E.I.T.



Attributes	
Title	Pflugerville Historic EST
Inspection Item	Interior Ladder
Condition	Unacceptable
Notes/Dimensions	The interior ladder is not OSHA compliant. There is moderate corrosion noted on the standoffs.
Inspector	Wesley Oatman, P.E., Dalton Warren, E.I.T., & Rachel Schober, E.I.T.



Attributes	
Title	Pflugerville Historic EST
Inspection Item	Overflow Pipe
Condition	Acceptable
Notes/Dimensions	There is moderate localized corrosion noted on the overflow pipe.
Inspector	Wesley Oatman, P.E., Dalton Warren, E.I.T., & Rachel Schober, E.I.T.



Attributes	
Title	Pflugerville Historic EST
Inspection Item	Roof
Condition	Acceptable
Notes/Dimensions	There is crevice corrosion along rivet seams. There is a section of conduit that runs to the finial ball.
Inspector	Wesley Oatman, P.E., Dalton Warren, E.I.T., & Rachel Schober, E.I.T.



Attributes	
Title	Pflugerville Historic EST
Inspection Item	Roof Structure
Condition	Unacceptable
Notes/Dimensions	The original roof to shell connections are mostly intact. There are missing j-bolts as noted previously in the report.
Inspector	Wesley Oatman, P.E., Dalton Warren, E.I.T., & Rachel Schober, E.I.T.



Attributes	
Title	Pflugerville Historic EST
Inspection Item	Interior Coating
Condition	Acceptable
Notes/Dimensions	The interior coating measures an average of 22.526 mils DFT.
Inspector	Wesley Oatman, P.E., Dalton Warren, E.I.T., & Rachel Schober, E.I.T.

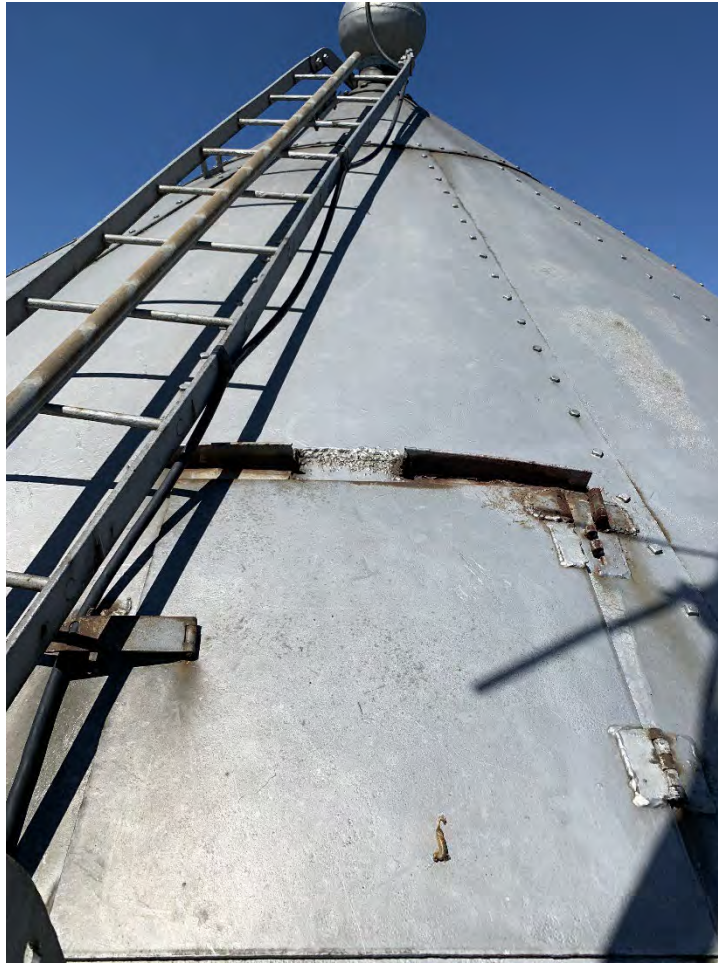

Attributes

Title	Pflugerville Historic EST
Inspection Item	Roof Manway
Condition	Unacceptable
Notes/Dimensions	The roof manway measures approximately 22" x 19" and is not OSHA compliant. The top hinge is broken, the hatch is not secured with a lock, and there is no raised curb to prevent water intrusion.
Inspector	Wesley Oatman, P.E., Dalton Warren, E.I.T., & Rachel Schober, E.I.T.

The obligations of the parties under this BOND shall be performable in Travis County, Texas and shall be construed under the laws of the State of Texas. If legal action is necessary in connection with this BOND, exclusive venue shall be in Travis County, Texas.

Surety companies executing this BOND must appear on the United States Treasury Department's most current list (Circular 570, as amended) and otherwise be authorized to transact business in the State of Texas.

IN WITNESS WHEREOF, the Principal and the Surety have hereunto set their hands and seals and such of them as are corporations have caused their corporate seals to be hereto affixed and these presents to be signed by their proper officers, the day and year first set forth above.

Signed and Agreed to this 20th day of June, 2024.

Lexington National Insurance Corporation
SURETY (seal)

By: 

(Signature)

James K Swindle

(Print Name)

Attorney-In-Fact

(Print Title)

[ATTACH POWER OF ATTORNEY]

ATTEST: 

PRINCIPAL/CONTRACTOR

By: 

(Signature)

Andrew Berteaux

(Print Name)

Managing Partner

(Print Title)

[Additional signatures, if any,
attached]

ATTEST: 

POWER OF ATTORNEY

Lexington National Insurance Corporation

Lexington National Insurance Corporation, a corporation duly organized under the laws of the State of Florida and having its principal administrative office in Baltimore County, Maryland, does hereby make, constitute and appoint:

James K. Swindle

as its true and lawful attorney-in-fact, each in their separate capacity, with full power and authority to execute, acknowledge, seal and deliver on its behalf as surety any bond or undertaking of \$1,500,000 or less. This Power of Attorney is void if used for any bond over that amount.

This Power of Attorney is granted under and by authority of the following resolutions adopted by the Board of Directors of the Company on February 15, 2018:

Be it Resolved, that the President or any Vice-President shall be and is hereby vested with full power and authority to appoint suitable persons as Attorney-in-Fact to represent and act for and on behalf of the Company subject to the following provisions:

Attorney-in-Fact may be given full power and authority for and in the name of and on the behalf of the Company, to execute, acknowledge and deliver any and all bonds, contracts, or indemnity and other conditional or obligatory undertakings, including any and all consents for the release of retained percentages and/or final estimates on engineering and construction contracts, and any all notices and documents cancelling or terminating the Company's liability thereunder and any such instruments so executed by any Attorney-in Fact shall be binding upon the Company as if signed by the President and sealed by the Corporate Secretary.

RESOLVED further, that the signature of the President or any Vice-President of LEXINGTON NATIONAL INSURANCE CORPORATION may be affixed by facsimile to any power of attorney, and the signature of the Secretary or any Assistant Secretary and the seal of the Company may be affixed by facsimile to any certificate of such power, or any such power or certificate bearing such facsimile signature or seal shall be valid and binding on the Company. Any such power so executed and sealed and certified by certificate so executed and sealed with respect to any bond to which it is attached continue to be valid and binding upon the Company.

IN WITNESS WHEREOF, the Company have caused this instrument to be signed and their corporate seal to be hereto affixed.



Ronald A. Frank, President



State of Maryland
County of Harford County, SS:

Before me, a notary public, personally appeared, Ronald A. Frank, President of Lexington National Insurance Corporation, who proved to me on the basis of satisfactory evidence to be the person whose name is subscribed to the within instrument and acknowledged to me that he executed the same in his capacity, and that by his signature on the instrument the person, or the entity upon behalf of which the person acted, executed the instrument.

I certify under the PENALTY of PERJURY under the laws of the State of Maryland that the foregoing paragraph is true and correct.

WITNESS my hand and official seal.

Commission Expires: 05/23/24

Notary

I, Lisa R. Slater, Secretary of Lexington National Insurance Corporation, do hereby certify that the above and foregoing is true and correct copy of a Power of Attorney, executed by said company, which is still in full force and effect; furthermore, the resolutions of the Boards of Directors, set out in the Power of Attorney are in full force and effect.

In Witness Whereof, I have hereunto set my hand and affixed the seal of said Company at Baltimore, Maryland this 20th day of June 2024

Corporate Seal:

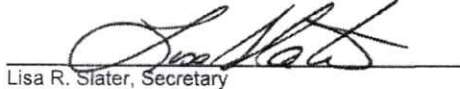
Lisa R. Slater, Secretary